

TECO

e-motion

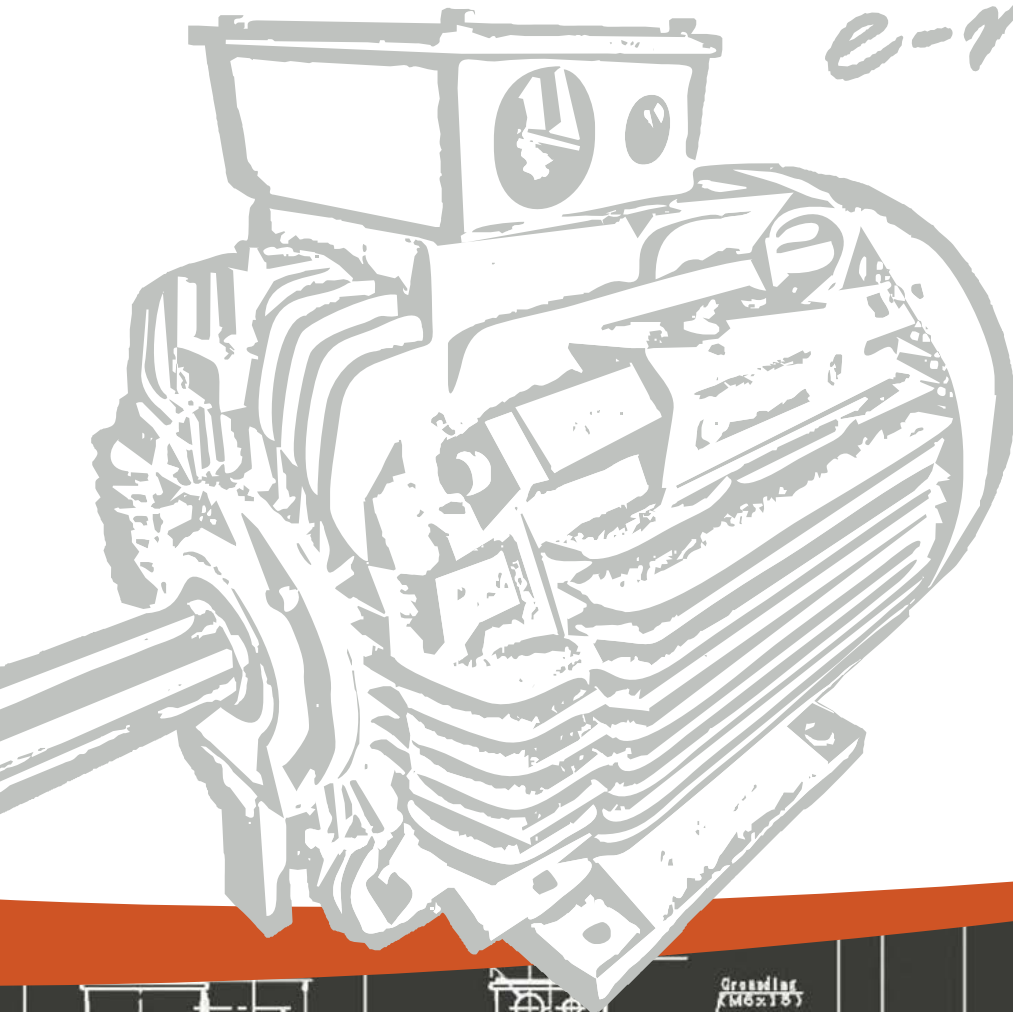

Technical Catalogue

2014

Whilst every care has been taken to ensure the accuracy of the information contained in this publication, due to a policy of continuous product development and improvement we reserve the right to supply products which may differ slightly from those drawn or described in this publication.

For critical applications please refer to your local TECO Office.

Table of Contents

1	General	6
1.1	Standards and regulations.....	6
1.2	Basics, terms and definitions	9
1.2.1	Power rating	9
1.2.2	Frame size.....	9
1.2.3	Mounting arrangement	9
1.2.4	Construction and construction material	10
1.2.5	Cooling	11
1.2.6	Degrees of protection	11
1.2.7	Performance characteristics: Speed, torque.....	11
1.2.8	Electrical performance characteristics	12
2	AC Motors, European Design	14
2.1	Range of motors covered by this catalogue; variety of characteristics	14
2.2	TECO type code (“Motor Identification Code”).....	15
3	Mechanical design.....	16
3.1	Housing, mounting arrangement	16
3.2	Terminal box and cable entry	21
3.3	Cooling	26
3.4	Rotor assembly (active part, shaft, bearings)	27
3.4.1	General.....	27
3.4.2	Shaft	28
3.4.3	Bearings	28
3.4.4	Regreasing	32
3.5	Degree of protection	33
3.6	Others.....	34
3.6.1	Grounding terminals	34
3.6.2	Lifting eyes	34
3.6.3	Drain holes	35
3.6.4	SPM provision	35
3.6.5	Painting, corrosion protection	35
3.6.6	Rating plate and labelling	36
4	Electrical design	37
4.1	Stator winding.....	37
4.2	Thermal protection.....	39
5	Performance data	40
5.1	Duty type	40
5.2	Environmental conditions, performance	40
5.2.1	Operation at high ambient temperature/high altitude.....	40
5.2.2	Operation at low temperature/high humidity	41
5.2.3	Operation at severe mechanical conditions.....	42
5.3	Mechanical performance	42
5.3.1	Torque characteristic; starting performance	42
5.3.2	Maximum operational speed.....	43
5.3.3	Permissible radial shaft forces.....	44
5.3.4	Permissible axial shaft forces	46

5.3.5	Vibration.....	47
5.4	Motor performance (line operated).....	47
5.4.1	Requirements for supply voltage and frequency	48
5.4.2	Current, power factor and efficiency at partial load	48
5.4.3	Current during starting, limitations	49
5.5	Motor performance (inverter operated)	51
5.5.1	General	51
5.5.2	Operational range; principle	52
5.5.3	Operational range for continuous operation	53
5.5.4	Winding insulation stress	55
5.5.5	Inverter caused bearing currents	56
5.5.6	Electromagnetic compatibility.....	57
5.5.7	Additional acoustic noise.....	57
6	Technical data	58
6.1	General data; tolerances (acc. to IEC 60034-1).....	58
6.2	Type data for aluminium version	59
6.2.1	Aluminium; 400 V; 50 Hz; Class IE2	60
6.2.2	Aluminium; 460 V; 60 Hz; Class IE2	64
6.3	Type data for cast iron version	68
6.3.1	Cast iron; 400 V; 50 Hz; Class IE2.....	68
6.3.2	Cast iron; 400 V; 50 Hz; Class IE3.....	72
6.3.3	Cast iron; 460 V; 60 Hz; Class IE2.....	75
6.3.4	Cast iron; 460 V; 60 Hz; Class IE3.....	79
7	Outline drawings	82
7.1	Aluminium design.....	82
7.2	Cast iron design	88
7.2.1	Cast iron design; feet version (B3).....	88
7.2.2	Cast iron design; flange version (B5).....	95
7.2.3	Cast iron design; version with feet and flange (B35).....	100
7.2.4	Cast iron design; V1.....	106
8	Spare parts	113
8.1	Aluminium motors	113
8.2	Cast iron motors.....	115
9	Packing, labelling.....	119
9.1	Packing design.....	119
9.1.1	Motors up to frame size 90.....	119
9.1.2	Motors frame size 100 to 315.....	120
9.2	Labelling.....	120
10	Quality assurance	121
11	Documentation	122

TECO History

- 1956** Company foundation and start of production in the first **TECO** factory in San-Chung, TAIWAN
- 1965** Production capacity increased by opening new factory in Shin-Chuan, TAIWAN
- 1966** Start of close technical co-operation with Hitachi, Yaskawa and Taiyo
- 1979** Increased production capacity by opening factory in Chung Li, TAIWAN Plant I (Heavy Motor Plant)
- 1987** Opened Chung Li Plant II for serial motor production (Small Motor Plant), TAIWAN
- 1987** Started Joint Venture with Westinghouse Motor Company, USA, one of the leading motor manufacturers in North America
- 1991** Founded **TECO** Perai, Penang Province, MALAYSIA, low voltage motors for local market
- 1993** Established **TECO Electric Europe** in Manchester, UNITED KINGDOM to start presence in Europe
- 1995** 100% take over of Westinghouse motor business by **TECO**. Established **TECO-Westinghouse Motor Company**, USA
- 2000** Opened **TECO** factory for low voltage motors in Suzhou, Jiangsu Province, CHINA
- 2003** Opened **TECO** factory for low and medium voltage motors in Wuxi, CHINA
- 2005** Opened third **TECO** factory in Nanchang, Jiangxi Province, CHINA
- 2006** Opened factory in Huyen Long Thanh, Tinh Dong Nai Province, VIETNAM
- 2008** Opened **TECO** repair plant in Dammam, KINGDOM OF SAUDI ARABIA, on joint venture basis
- 2009** Established **TECO** Fuan in Fujian Province, CHINA
- 2010** Starting the production of aluminium motors and semi finished aluminium parts at **TECO** Fuan factory in Fujian Province, CHINA
- 2012** Established India branch office
- 2013** Established Turkey branch office

TECO General

In 2013 TECO operates in 45 countries worldwide and affiliates gained a turnover of 1.9 Billion EURO, with approximately 20.000 employees worldwide. More than 50% of the turnover was generated by the Electric Motor business. TECO is listed in the stock exchange in Taipei, TAIWAN. Detailed financial data can be downloaded from the TECO website http://www.teco.com.tw/en_version, under "Investor Relations".

TECO is mainly focused on

- Sustainable development with new competitive advantages
- Enhancing service quality
- Development and education of experienced employees
- Creating outstanding products

TECO has

- Significant Experience in the Motor Industry
- Experienced Engineering and Manufacturing Staff
- State of the art factories in the most important manufacturing markets
- State of the art Testing Facilities for the full power and voltage range of its motors

TECO Europe

TECO Europe currently has direct local presences in Germany, UK, the Netherlands, and Spain. TECO Europe also networks with competent sales and services partners in most of the markets within the European Union to provide local professional technical and sales supports. TECO Europe also has major warehouses located in the Netherlands and UK to support various logistic needs.

In Europe, along with well-known TECO-Westinghouse **Medium Voltage Motors**, TECO manufactures full range **Low Voltage Stock Motors** to **IE2 & IE3** standard, with both cast iron and aluminium cases. With the recently released 510 Series, TECO offers high performance and cost effective wide range of **Variable Speed Drives** that fit virtually all applications. So whatever your motor and drive requirement our experienced engineering team can help and advise on the correct products to suit your applications.

References in this catalogue:

- *TECO Manual "INSTALLATION, OPERATION and MAINTENANCE INSTRUCTIONS FOR TECO LOW VOLTAGE MOTORS Type ALAA and ALCA"*
- *TECO short form safety instructions*

TECO Scope of Supply:

Low Voltage 0,12 to 1000 kW	Three Phase Asynchronous Motors	Cast Iron Aluminium Open Drip Proof		
	High Efficiency Motors	IE2 Cast Iron IE3 Cast Iron IE2 Aluminium IE3 Aluminium NEMA Premium Efficiency		
	Single Phase Motors	Capacitor-Start Capacitor-Start, Capacitor Run Split Phase Start		
	Explosion Proof Motors	Non Sparking Flameproof Increased Safety Dust Ignition Proof		
	Vertical Motors	Solid Shaft High Thrust Hollow Shaft High Thrust		
	Special Purpose Motors	Inverter Duty Pole Changing Smoke Extraction Brake Motor Marine Duty Extended Shaft End Double Shaft End Hollow Shaft Crusher Duty Submersible Crane Duty Wind Generator Cooling Fan Design Pump jack (Oil Well) Design		
	3 Phase Drives	0.4–1000kW 200, 400, 690V Constant/Variable Torque models IP00, IP20, IP54, IP65 V/F and Flux Vector		
	Single Phase Drives	0.18–2.2kW IP20 and IP65 V/F and Flux Vector		
	High Voltage 0,315 to 45 MW	3 Phase Motors	Asynchronous Synchronous Slip ring	
		Explosion Proof Motors	Non Sparking Flameproof Increased Safety Dust Ignition Proof	
		Vertical Motors	Solid Shaft High Thrust Hollow Shaft High Thrust	
		Special Purpose	Inverter Duty Pole Changing Marine Duty Extended Shaft End Double Shaft End Crusher Duty Wind Generator	
		Special Design	Wound Rotor Induction Motors	
			Permanent Magnet Motors	
			DC Motors	Series Type Shunt Type Compound Type

1 General

1.1 Standards and regulations

There are different international standards for electrical machines, e.g.

- the international "IEC" standard or
 - the North American "NEMA"-standard and others.
- The motors covered by this catalogue are designed and manufactured according to the latest IEC standards. Furthermore they fulfil the relevant regulations of the European Community ("EC Regulations").

List of national and international standards and regulations applied:

Title	International IEC	Europe EN/Directive	Germany DIN/VDE
Rotating electrical machines – Part 1: Rating and performance	60 034-1	60 034-1	DIN EN 60 034-1 VDE 0530 Part 1
Rotating electrical machines – Part 2-1: Standard methods for determining losses and efficiency from tests	60 034-2-1: 2007	60 034-2-1: 2007	DIN EN 60 034-2 VDE 0530 Part 2
Rotating electrical machines – Part 5: Degrees of protection provided by the integral design of rotating electrical machines (IP code) – Classification	60 034-5	60 034-5	DIN EN 60 034-5 VDE 0530 Part 5
Rotating electrical machines – Part 6: Methods of cooling (IC Code)	60 034-6	60 034-6	DIN EN 60 034-6 VDE 0530 Part 6
Rotating electrical machines – Part 7: Classification of types of construction, mounting arrangements and terminal box position (IM Code)	60 034-7	60 034-7	DIN EN 60 034-7 VDE 0530 Part 7
Rotating electrical machines – Part 8: Terminal markings and direction of rotation	60 034-8	60 034-8	DIN EN 60 034-8 VDE 0530 Part 8
Rotating electrical machines – Part 9: Noise limits	60 034-9	60 034-9	DIN EN 60 034-9 VDE 0530 Part 9
Rotating electrical machines – Part 11: Thermal protection	60 034-11	60 034-11	
Thermistors, PTC			DIN 44081:1980-6
Rotating electrical machines – Part 12: Starting performance of single-speed three-phase cage induction motors	60 034-12	60 034-12	DIN EN 60 034-12 VDE 0530 Part 12
Rotating electrical machines – Part 14: Mechanical vibration of certain machines with shaft heights 56 mm and higher – Measurement, evaluation and limits of vibration severity	60 034-14	60 034-14	DIN EN 60 034-14 VDE 0530 Part 14
Rotating electrical machines – Part 17: ³⁾			
Cage induction motors when fed from converters-Application guide	TS 60034-17		
Mechanical vibration; balancing shaft and fitment key convention			DIN ISO 8821
Mechanical vibration – Balance quality requirements for rotors in a constant (rigid) state – Part 1: Specification and verification of balance tolerances			DIN ISO 1940-1: 2004-04

Title	International IEC	Europe EN/Directive	Germany DIN/VDE
Rotating electrical machines – Part 30: Efficiency classes of single-speed, three- phase, cage-induction motors (IE-code)	60 034-30		
IEC standard voltages	60 038	—	DIN IEC 60 038
Dimensions and output series for rotating electrical machines – Part 1: Frame numbers 56 to 400 and flange numbers 55 to 1080	60 072-1 ¹⁾	50 347	DIN EN 50 347 ²⁾
Electrical insulation – Thermal evaluation and designation	60 085	—	DIN IEC 60 085
Safety of electrical Machines – Electrical equipment of Machines Part 1: Common Requirements	60 204-1	60 204-1	DIN EN 60 204-1 VDE 0113-1
Electro technical graphical symbols	60 617-2	60 617-2	DIN EN 60 617-2
Drive Type Fastenings without Taper Action; Parallel Keys, Keyways, Deep Pattern			DIN 6885-1
Hexagonal screws			DIN EN ISO 4014
Hexagonal nuts			DIN EN ISO 4032
Lubricating nipples; button head			DIN 3404
Protection of steel structures from corrosion by organic and metallic coatings			DIN 55 928
Low Voltage Directive 2006/95/EC		2006/95/EC	
EMC Directive 2004/108/EC		2004/108/EC	
Machinery Directive 2006/42/EC ⁴⁾		2006/42/EC	

¹⁾ Applicable for dimensions and frame sizes only

²⁾ Applicable for single speed motors up to frame size 315M only

³⁾ As far as applicable

⁴⁾ Not directly applicable for low voltage motors

Table 1-1: Standards and regulations applied

Remarkable latest innovations in above mentioned standards are:

- IEC 60034-2-1 (...standard methods for determining losses and efficiency from tests) and
- IEC 60034-30 (...efficiency classes of single-speed, three-phase cage-induction motors; IE-code).

By IEC 60034-2-1 an improved procedure for testing of the efficiency is described. In general the nominal efficiency evaluated by this method is slightly lower than the value based on the formerly used procedure. IEC 60034-30 defines classes of efficiency for standard motors ("International Efficiency"):

- "IE1" (Standard Efficiency),
- "IE2" (High Efficiency),
- "IE3" (Premium Efficiency) and
- "IE4" (Super Premium efficiency).

These efficiency class definitions demand a minimum efficiency value depending on power rating and pole number of the motor. (This classification replaces the formerly used efficiency class definitions like e.g. "eff1".) The motors in this catalogue (category IE2 and IE3) fulfil ore override these minimum levels.

Depending on local regulations the current and future use of these advanced motors is mandatory. The current regulation within the European Community is EG 640/2009, as a part of the EU's eco-design project. It covers 2-, 4-, 6- and 8-pole three phase low voltage induction motors with power rating from 0,75 kW up to 375 kW (excepted of special motors like explosion proof motors and others). Schedule for mandatory use of these motors:

- June 2011: efficiency class IE2 for all motors covered by this regulation
- January 2015: efficiency class IE3 for motors from 7,5 kW up to 375 kW (or IE2 if inverter operated)
- January 2017: efficiency class IE3 for all motors from 0,75 kW up to 375 kW (or IE2 if inverter operated).

A sample for efficiency requirements is given in the figure below (4-pole motors, classification "IE2" and "IE3"):

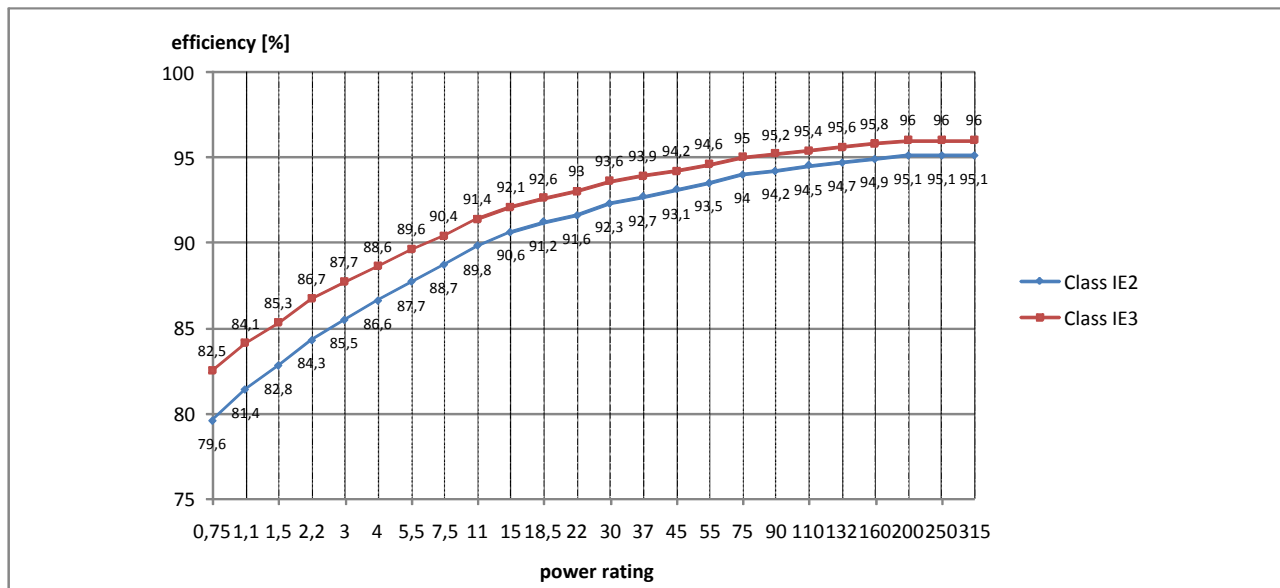

Figure 1-1: Minimum nominal efficiency for 4-pole motors acc. class IE2 and IE3 (IEC 60034-30)

1.2 Basics, terms and definitions

Induction machines are the commonly most used motor type for general drive applications. They are extremely durable and robust and provide an economic drive solution, even under severe environmental conditions. They can be used for direct line operation (fixed speed) or in combination with a frequency inverter (variable speed drive system). They are available in a lot of varieties. Some typical characteristics are listed below:

1.2.1 Power rating





The power rating of electrical motors refers to the mechanical shaft output power (in opposite: for electrical generators the rating refers to the electrical power at the terminals). Within the IEC standard range (up to 315 kW) standardized values for the rating are defined (e.g. 37 kW, 45 kW etc.).

1.2.2 Frame size

The frame size is defined as the distance [mm] between the mounting level and the centre of the shaft (in case of floor mounted arrangement; accordingly a definition is stated for flange mounted arrangement). Standard values for the frame sizes are defined for the IEC standard range (e.g. frame size 200, 225 etc.). In addition a fixed coordination between power rating and frame size is defined in IEC 60072-1. Within a defined frame size several types can be designed with different lengths.

1.2.3 Mounting arrangement

Rotating electrical machines can be delivered in a large variety of possible physical arrangements. In IEC 60034-7 the construction and arrangement is classified, (IM code as e.g. "IM B3"). Mechanical interface dimensions and their tolerances are standardized for each frame size. Table of some typical arrangements:

Mounting	Code acc. IEC 60034-7		Description	
	Code I	Code II	Feet	Flange
Horizontal use:				
	IM B3	IM 1001	with feet	—
	IM B5	IM 3001	—	with flange (clearance fixing holes)
	IM B14	IM 3601	—	with flange (tapped fixing holes)
	IM B34	IM 2101	with feet	with flange (tapped fixing holes)





Mounting	Code acc. IEC 60034-7		Description	
Diagram	Code I	Code II	Feet	Flange
	IM B35	IM 2001	with feet	with flange (clearance fixing holes)
Vertical use:				
	IM V1	IM 3011	—	with flange (clearance fixing holes) shaft up
	IM V3	IM 3031	—	with flange (clearance fixing holes) shaft down
	IM V5	IM 1011	with feet shaft down	—
	IM V6	IM 1031	with feet shaft up	—

Table 1-2: Relevant IM arrangements (selection)

1.2.4 Construction and construction material

The relevant components are:

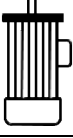
- Stator housing with active stator parts inside (magnetic core, stator winding),
- End shields with bearings,
- Shaft with active rotor parts (magnetic core, squirrel cage),
- Cooling system,
- Terminal box.

Housing, end shields and terminal box can be manufactured in aluminium (preferable at small machines), cast iron (medium size machines) or welded steel (large machines).

1.2.5 Cooling

Cooling can be carried out either with ambient air or with cooling water with a large variety of detailed constructions. Principle arrangements of the cooling are defined in IEC 60034-6 (IC code). In the range of IEC standard motors as presented in this catalogue the cooling system in general is "IC 411": Totally Enclosed Surface Fan cooled ("TEFC") as shown in the sample picture above.

1.2.6 Degrees of protection

The level of protection against environmental conditions like water, dust, etc. is defined in 60034-5 (IP code as e.g. "IP55"). The user has to choose a sufficient degree of protection according to his environmental conditions.

1.2.7 Performance characteristics: Speed, torque

(Only induction motors with a rotor in "squirrel cage" design regarded here; no "wound rotor" types). If operated at a grid with fixed voltage and frequency the nominal speed ("full load speed") is near to the "no-load speed" (also called "synchronous speed"): this is defined by the grid frequency and the "pole number" of the motor (also called "2p" with "p" as the number of pole pairs):

Motor design	2-pole	4-pole	6-pole	8-pole
No load speed at 50 Hz grid	3000 rpm	1500 rpm	1000 rpm	750 rpm
No load speed at 60 Hz grid	3600 rpm	1800 rpm	1200 rpm	900 rpm

Table 1-3: No load speed

The starting performance is standardized by IEC 60034-12 ("Starting performance of single-speed three-phase cage induction motors"). The motors covered by this catalogue comply with "IEC 60034-12, Design N". The typical characteristic of the torque versus speed is shown in the diagram below:

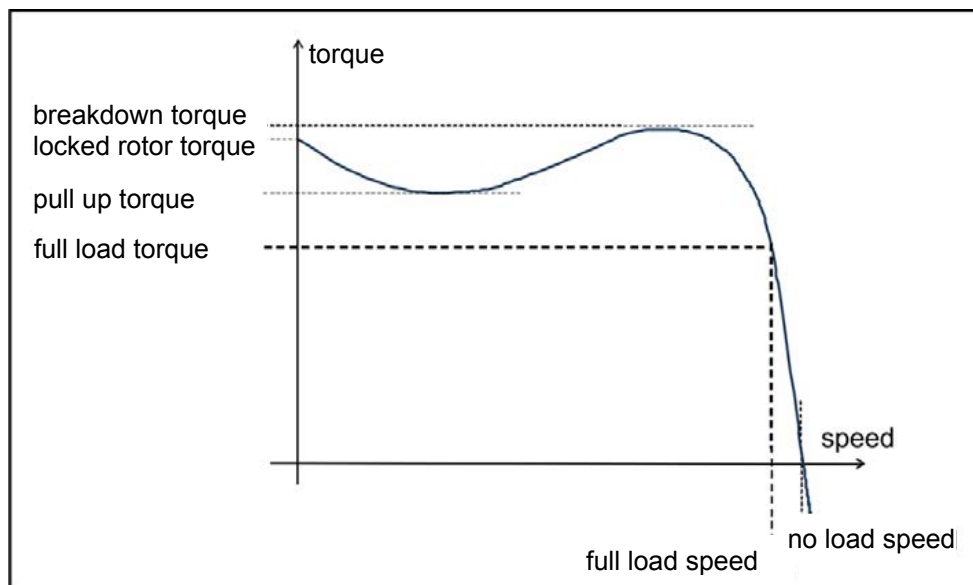

Figure 1-2: Typical characteristic for induction motors: Torque versus speed

Characteristic points which are content of the type data:

- Full load speed ("nominal speed")
- Full load torque ("nominal torque")
- Locked rotor torque ("starting torque"); as a multiple of nominal
- Pull up torque; as a multiple of nominal
- Breakdown torque; as a multiple of nominal.

1.2.8 Electrical performance characteristics

According to 1.2.7 Performance characteristics: Speed, torque the typical characteristic of current and power factor is shown in the diagram below:

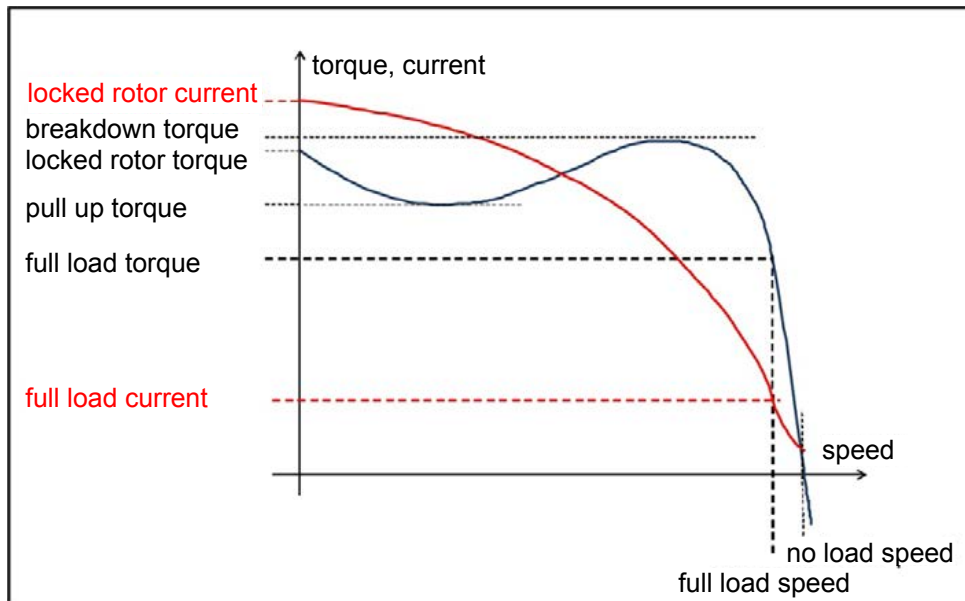

Figure 1-3: Typical characteristic for induction motors: Torque and current versus speed

Characteristic points which are content of the type data (see 6 Technical data, starting page 58):

- Full load current ("nominal current")
- Full load power factor
- Locked rotor current; as a multiple of nominal.

At different load points (partial load, overload) the values for current, power factor and efficiency are varying; a typical characteristic is shown in diagram below. The values of power factor and efficiency for each motor type are listed in section 6 for the load points 1/4; 2/4 and 3/4 partial load.

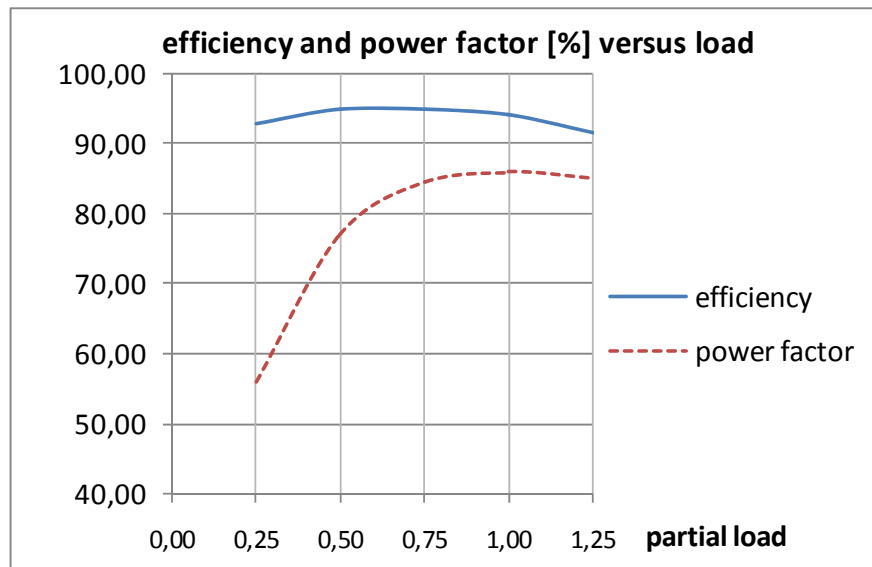

Figure 1-4: Typical characteristic for a TECO motor (30 kW): power factor and efficiency at partial load

2 AC Motors, European Design

2.1 Range of motors covered by this catalogue; variety of characteristics

Common characteristics	Three phase low voltage motors according to IEC standard, single speed, totally enclosed, for <i>Standard Safe Area</i>
Power rating	0,18 kW–315 kW
Frame size	63–315
Pole number	2-pole; 4-pole; 6-pole; 8-pole
Line Frequency	50 Hz; 60 Hz
Type of mounting	Feet version, flange version and combinations
Construction material	Aluminium or Cast Iron
Efficiency class acc. IEC	Cast iron motors: IE2 and IE3 (identical dimensions) Aluminium motors: IE 2
Accessories	Standard or with options (e. g. forced ventilation)
Standards	IEC standards, European directives (CE marking). Compliance with additional regulations for applications non essential service: “GL Rules and guidelines 2011” “BV Rules and guidelines 2011” “LR Rules and Regulations for the classification of ships, 2011” “DNV Rules for Ships/High Speed, Light Craft and Naval Surface Craft, January 2011”

Table 2-1: Motors covered by this catalogue

2.2 TECO type code (“Motor Identification Code”)

The type code is covering the overall range of TECO induction motors. It is explained for a sample motor type “ALCA-0160MC-30004-IZ”: A low voltage 3 phase AC motor for application in “Safe Area”, with aluminium housing; frame size 100; 4-pole; according IEC standards; optional version with accessories.

Type Key / Motor Identification Code / Type Code				A	L	C	A	-	0	1	0	0	L	2	-	1	0	0	0	4	-	I	Z				
				Digit No.	1	2	3	4	5	6	7	8	9	10	11	12	13	14	15	16	17	18	19	20			
				Attribute No.	1	2	3	4	5	6			7			8			9			10			11	12	13
No.	Attribute	Character	Specification																								
1	Design	A	Standard Safe Area																								
		F	Flameproof "Ex d(e)"																								
		G	Generator Synchronous Standard Safe Area																								
		I	Increased Safety "Ex e"																								
		N	Non Sparking "Ex n"																								
		P	Pressurized "Ex p"																								
		S	Smokespill																								
		Z	Special																								
2	Voltage	H	High Voltage 3~																								
		L	Low Voltage 3~																								
		S	Low Voltage 1~																								
		Z	Special																								
3	Frame Material	A	Aluminum Mould Cast																								
		B	Aluminum String Cast																								
		C	Cast Iron																								
		R	Rolled Steel																								
		Z	Special																								
4	Cooling	A	IC 411 TEFC Totally Enclosed Surface Fan Cooled																								
		B	IC 511 Tube Cooled																								
		C	IC 611 Air to Air Heat Exchanger																								
		F	IC 416 TEFV Totally Enclosed Forced Ventilation																								
		K	IC 410 TENV Totally Enclosed Non Ventilated (Convection)																								
		O	IC 01 Open Circuit Ventilation																								
		W	IC 81W Water to Air Heat Exchanger																								
		Z	Special																								
5																											
6	Frame Size	63																									
		up to 9000																									
7	Core Length	A																									
		up to XX																									
8																											
9	Poles	1	Single Speed																								
		2	2-times Pole Changing																								
		3	3-times Pole Changing																								
10	Poles	2																									
		4																									
		6																									
		up to 1284																									
11																											

Remarks for digits 13 to 17: "31284" e.g. is defined as "3 speed, with 12 pole, 8 pole and 4 pole winding".

Table 2-2: TECO type code

3 Mechanical design

3.1 Housing, mounting arrangement

All construction components are shown for a sample motor in the figure below:

- | | | |
|------------------------|---------------------------------|----------------------------------|
| 01 Shaft cover | 16 Washer | 31 External Earth terminal assy |
| 02 Oil Seal | 17 Eye bolt | 32 Inner bearing cover |
| 03 Outer bearing cover | 18 Name plate carrier | 33 Bearing stop ring |
| 04 Grease drain cover | 19 Name plate | 34 Bearing |
| 05 End shield DE | 20 Terminal box plate | 35 Pre-load spring |
| 06 Grease nipple | 21 Blind plug | 36 End shield NDE |
| 07 Bearing | 22 Terminal box housing | 37 Grease nipple |
| 08 Bearing stop ring | 23 Fixed seat | 38 Grease drain cover |
| 09 Inner bearing cover | 24 Power connecting assy | 39 Outer bearing cover |
| 10 Shaft | 25 Internal Earth terminal assy | 40 Oil seal |
| 11 Key | 26 Power terminals | 41 External fan |
| 12 Rotor | 27 Hex nut | 42 Fan cowl |
| 13 Stator | 28 Star-Delta jumpers | 43 Detachable gland plate Gasket |
| 14 Frame | 29 Terminal box gasket | 44 Detachable gland plate |
| 15 Feet | 30 Terminal box cover | |

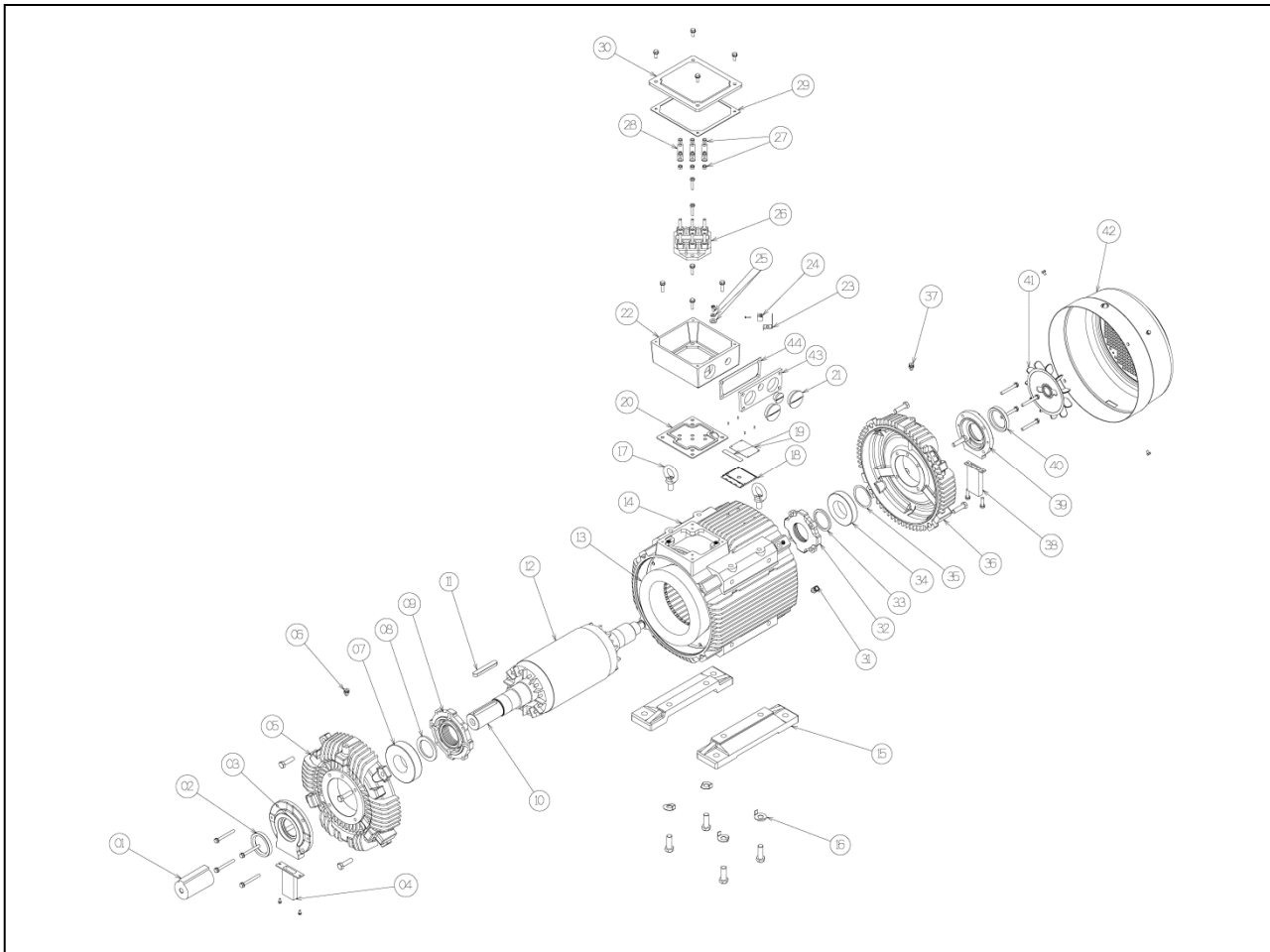

Figure 3-1: "Exploded" drawing of a sample TECO motor

The motors are available in the versions:

- Aluminium housing (type code e.g. "ALAA-.....") or
- Cast iron housing (type code e.g. "ALCA-.....").

Power ratings	Depending on pole number, see 6 Technical data, starting page 58.													
Frame size	63	71	80	90	100	112	132	160	180	200	225	250	280	315
Aluminium	X	X	X	X	X	X	X	X						
Cast iron			X	X	X	X	X	X	X	X	X	X	X	X

Table 3-1: Motor versions available

The motors can be delivered for many types of mounting:

- Feet version (IM code B3, suitable for arrangements B6, B7, B8, V5, V6); with top mounted terminal box (standard configuration)
- Flange version with clearance fixing holes (IM code B5, suitable for arrangements V1 and V3) or
- Flange version with tapped fixing holes (IM code B14, suitable for arrangements V18 and V19) or
- Version with feet and flange with clearance fixing holes (IM code B35, suitable for V15 and V36) or
- Version with feet and flange with tapped fixing holes (IM code B34).

To be regarded only for motors with frame size 315; 2-pole: Vertical use (V-mountings) is only admissible in a special design; this has to be defined in the order.



Figure 3-2: Sample of a TECO motor (feet version)



Figure 3-3: Sample of a TECO motor (flange version)

Dimensions:

All external dimensions of the motor (shaft height, length) for a defined motor rating are identical for the IE2- and the IE3-version. This allows variability for the user depending on the application. The dimensions and tolerances for the mechanical interface (e. g. positions of feet holes) are defined by IEC 60072-1.

Multi-mount symmetric design – Axial direction:

The motor housing is designed to allow for a large variety of mounting arrangements. It is symmetric in axial direction (DE – NDE), except of the asymmetric position of the terminal box. Therefore the user can change the axial position of the terminal box according to the individual spatial conditions at his construction (front or back) by changing the position of the rotor including DE and NDE end shield. Due to a special design of the DE end shield this modification can be carried out without dismantling the NDE assembly. (To be regarded when carrying out this modification: the rotational direction of the motor is no longer acc. to IEC 60034-8 then. Precautions shall be made to prevent disturbances. Modification of mounting arrangement shall only be carried out by qualified personnel; regard the guidelines in the TECO manual “INSTALLATION, OPERATION and MAINTENANCE INSTRUCTIONS....”)



Figure 3-4: Multi-mount design (in axial direction); terminal box “Drive End”

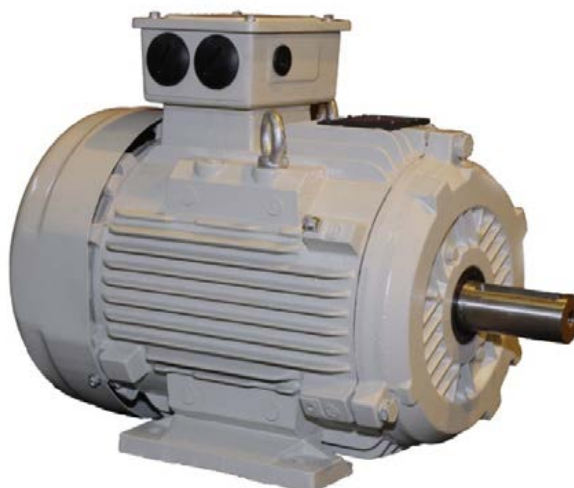

Figure 3-5: Multi-mount design (in axial direction); terminal box "Non drive end"

SDF

As a standard the "feet" – in SDF version (B3; B34; B35) are delivered with a top mounted terminal box. In the "Standard Detachable Feet" (SDF) version; the feet can be detached if required.

ADF

In the optional version "Advanced Detachable Feet"; (ADF) the housing is machined to be able to move the feet in 3 x 90° positions. Therefore the feet can easily be mounted in each of the 3 rotational positions and the 2 axial positions. All surfaces and all fixing holes for mounting the feet are machined, drilled, tapped and plugged. The holes (as well as others e.g. for lifting lugs, etc.) are designed as blind holes. If using the original feet a change of the feet position is possible without new alignment of the motor when feet are fixed in the new position.



Figure 3-6: Multi-mount design (top mounted terminal box)



Figure 3-7: Multi-mount design (terminal box in left hand side position)



Figure 3-8: Multi-mount design (terminal box in right hand side position)

Details for flange version

Possible mounting arrangements according to IEC 60034-7: B5, V1, V3. All customer interface dimensions (hole circle diameter, centring diameter, etc.) and their tolerances are defined by IEC 60072-1. For a number of motor frame sizes as an option flanges with external dimensions equivalent to larger or smaller frame sizes are available on request; see tables:

Available FF(A) – Flanges (clearance fixing holes)														
Frame size	FF [mm]	100	115	130	165	215	265	300	350	400	500	600	740	940
	A [mm]	120	140	160	200	250	300	350	400	450	550	660	800	1000
63			X	X										
71				X	X									
80					X	X								
90					X	X								
100						X	X							
112						X	X							
132							X	X						
160								X	X					
180								X						

Available FF(A) – Flanges (clearance fixing holes)														
Frame size	FF [mm]	100	115	130	165	215	265	300	350	400	500	600	740	940
	A [mm]	120	140	160	200	250	300	350	400	450	550	660	800	1000
200									X					
225										X				
250											X			
280											X			
315												X		

FF = hole circle X = standard
A = diameter X = available on request

Table 3-2: Flange sizes available (B5; clearance fixing holes)

Available FT(C) – Flanges (tapped fixing holes)														
Frame size	FT [mm]	65	75	85	100	115	130	165	215					
	C [mm]	80	90	105	120	140	160	200	250					
63		X	X	X										
71			X	X	X									
80				X	X	X								
90					X	X	X							
100						X	X	X						
112						X	X	X						
132							X	X	X					
160								X	X					
180								X						

FT = hole circle X = standard
C = diameter X = available on request

Table 3-3: Flange sizes available (B14; tapped fixing holes)

3.2 Terminal box and cable entry

As a standard the motors are delivered with a top mounted terminal box; located at the drive end, with cable entry to the right hand side. As described in 3.1 Housing, mounting arrangement, the position of the terminal box can easily be varied (left, right, front or back). Furthermore the terminal box itself is able to be rotated by steps of 90° to every direction to enable power cable entry from 4 directions (front, rear, left, right). (Guidelines for proper modification of the terminal box position: see TECO manual “INSTALLATION, OPERATION and MAINTENANCE INSTRUCTIONS....”)

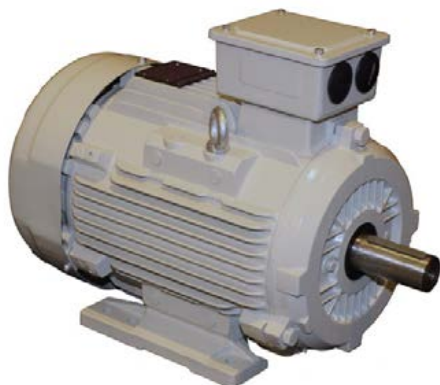

Figure 3-9: Cable entry front



Figure 3-10: Cable entry back



Figure 3-11: Cable entry left



Figure 3-12: Cable entry right

There are two cable entry holes for the power supply cable(s) and one entry hole for the cable for auxiliary devices, e. g. for thermistor connection. They are drilled, tapped and properly sealed; with threads according to table below. (The applicable cable outer diameter is dependent on the customer's cable gland type.)

All six winding lead ends from the windings are brought out and connected to a terminal block with metric threaded bolts for smaller motors or to metric duct connection bolts for bigger motors. Screws and nuts are hexagonal with metric thread and with ISO wrench sizes acc. to DIN EN ISO 4014 (screws) and DIN EN ISO 4032 (nuts). Three jumpers are attached to enable the customer a simple star or delta connection (see 4 Electrical design, starting page 37).

The lead ends of the standard thermistors (as well as optional accessories like space heaters) are connected to terminals (luster terminals or spring loaded serial terminals, see table below).

The terminals are marked and directed according to IEC 60034-8. A connection diagram sticker with the wiring diagram is fitted on the inside of the terminal box lid.

ALAA, cable entries for power and thermistors:

Frame size	Power Supply		Thermistor	
	Threads	Power connector bolts	Threads	Type of Connector
63	2 x M16 x 1.5	U-clamp		Luster terminal
71	2 x M16 x 1.5	U-clamp		Luster terminal
80	2 x M16 x 1.5	U-clamp		Luster terminal
90	2 x M25 x 1.5	U-clamp		Luster terminal
100	2 x M25 x 1.5	U-clamp		Luster terminal
112	1 x M32 x 1.5	U-clamp	1 x M25 x 1.5	Luster terminal
132	1 x M32 x 1.5	U-clamp	1 x M25 x 1.5	Luster terminal
160	2 x M40 x 1.5	Bolts	1 x M20 x 1.5	Serial terminal

ALCA, cable entries for power and thermistors:

Frame size	Power Supply		Thermistor	
	Threads	Power connector bolts	Threads	Type of Connector
63	1 x M20 x 1.5	U-clamp	M16 x 1.5	Luster terminal
71	1 x M20 x 1.5	U-clamp	M16 x 1.5	Luster terminal
80	2 x M25 x 1.5	U-clamp	M20 x 1.5	Luster terminal
90	2 x M25 x 1.5	U-clamp	M20 x 1.5	Luster terminal
100	2 x M32 x 1.5	U-clamp	M20 x 1.5	Luster terminal
112	2 x M32 x 1.5	U-clamp	M20 x 1.5	Luster terminal
132	2 x M32 x 1.5	U-clamp	M20 x 1.5	Luster terminal
160	2 x M40 x 1.5	Bolts	M20 x 1.5	Serial terminal
180	2 x M40 x 1.5	Bolts	M20 x 1.5	Serial terminal
200	2 x M50 x 1.5	Bolts	M20 x 1.5	Serial terminal
225	2 x M50 x 1.5	Bolts	M20 x 1.5	Serial terminal
250	2 x M63 x 1.5	Bolts	M20 x 1.5	Serial terminal
280	2 x M63 x 1.5	Bolts	M20 x 1.5	Serial terminal
315	2 x M63 x 1.5	Bolts	M20 x 1.5	Serial terminal

Table 3-4: Cable entries and connectors

Detailed mechanical dimensions depending on motor type: see 7 Outline drawings, starting page 82.

Options, on request:

From frame size 160 to 250 an optional attachment of one and from frame size 280 to 400 of two separate accessory terminal boxes is available (e.g.: different terminal boxes for different voltage levels may be demanded by customer specifications).

The motors can also be delivered without a terminal box on request. In this case we provide a blind plate with bushing for direct entry of customer specified cable(s).

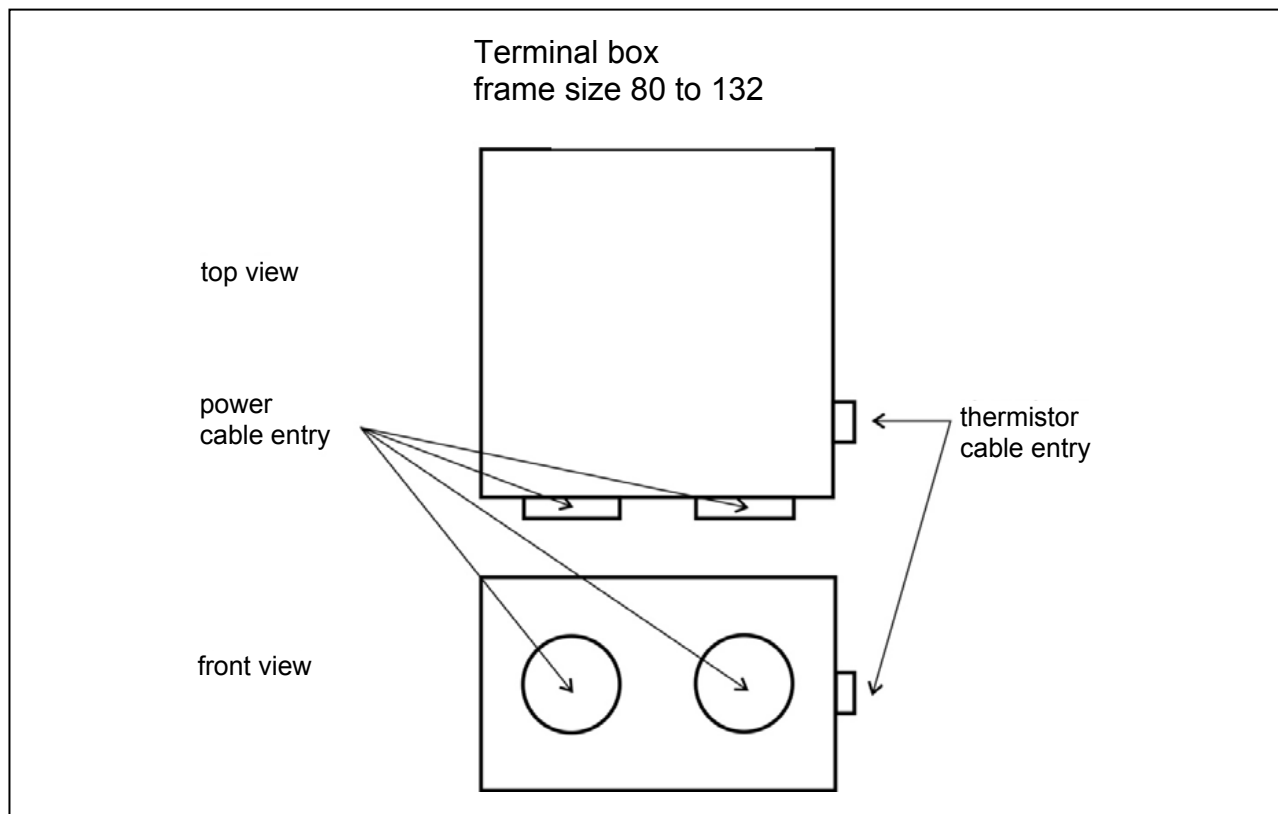

Figure 3-13: Position of cable entries (up to frame size 132)

Frame size 160 and above are equipped with a detachable steel plate on one side of the terminal box (cable entry plate). This is to enable customers an easy power supply connection and simple replacement of the motors with bulky cables as well as for later flexibility if customer asks for special amount of cable entry holes with special threads (special cable size or number of cables).

In these cases TECO can manufacture customized entry plates or blank plates on demand. Customer's cable glands: Insure the cable glands used are rated to an equal or better protection class than the motor.

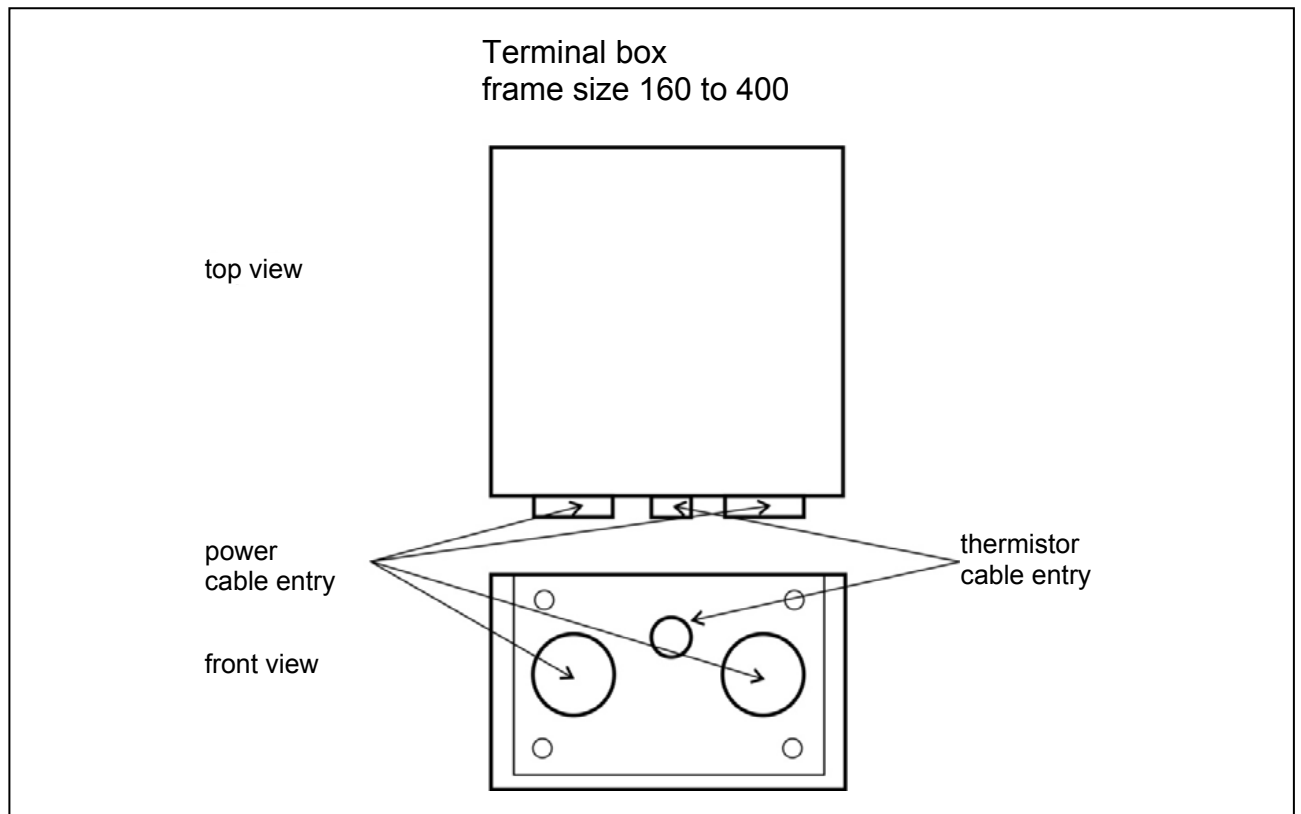

Figure 3-14: Position of cable entries (ALCA, frame size 160 to 315)



Figure 3-15: Detached entry plate

3.3 Cooling

As a standard the motors covered by this catalogue are “Totally Enclosed Surface Fan Cooled” (“TEFC”) acc. to the IEC code “IC 411”. This design provides cooling fins on the surface of the motor housing and a fan (and fan cowl) at NDE to generate a cooling air flow over these fins from NDE to DE. Even though acoustic noise is optimized, the fan is suitable for application in both directions of rotation (“bidirectional design”). The fan cowl is manufactured in steel sheet.



Figure 3-16: Cooling principle (“TEFC”)

In accordance with IEC standards the degree of protection for the cooling system is IP20 (even though the motor is classified in a much higher degree of protection, in this case IP55). The cooling system allows operation in any mounting position in principle. When mounted in a “shaft down position” precautions are required to prevent foreign bodies or excessive amount of water falling into the openings of fan. An accessory kit “Protection cover for shaft down motors” is available on request; it can be added easily in site.

The user has to take care that the air flow is not hindered or a high back pressure is generated when integrating the motor into his machine. As a general rule e.g. the distance between air inlet of motor and obstruction should be at least $\frac{1}{4}$ of the air inlet diameter of the fan cowl.

Options:

- A special design with “uni-directional” fan for acoustic noise reduction is available on request. In this case a sticker is mounted at the top of the front end shield which clearly indicates the direction of rotation. (acoustic noise level: see 5.3 Mechanical performance, starting page 42.
- Especially for frequency inverter operation (high speed or low speed range) a “Forced Ventilation” can be installed as an option. The fan then is operated by an additional motor to provide constant cooling independent from the main motor’s speed.

For special applications the motors can be delivered without ventilation. Power rating and duty type then have to be calculated by TECO acc. to customer’s request.

3.4 Rotor assembly (active part, shaft, bearings)

3.4.1 General

The active rotor part of a squirrel cage motor is a rugged arrangement only consisting of the magnetic lamination and the short circuit “winding” made of cast aluminium. It is mounted on the shaft manufactured from high tensile strength carbon steel. The bearings (including sealing) are supported in the end shields (aluminium or cast iron, according to motor type).

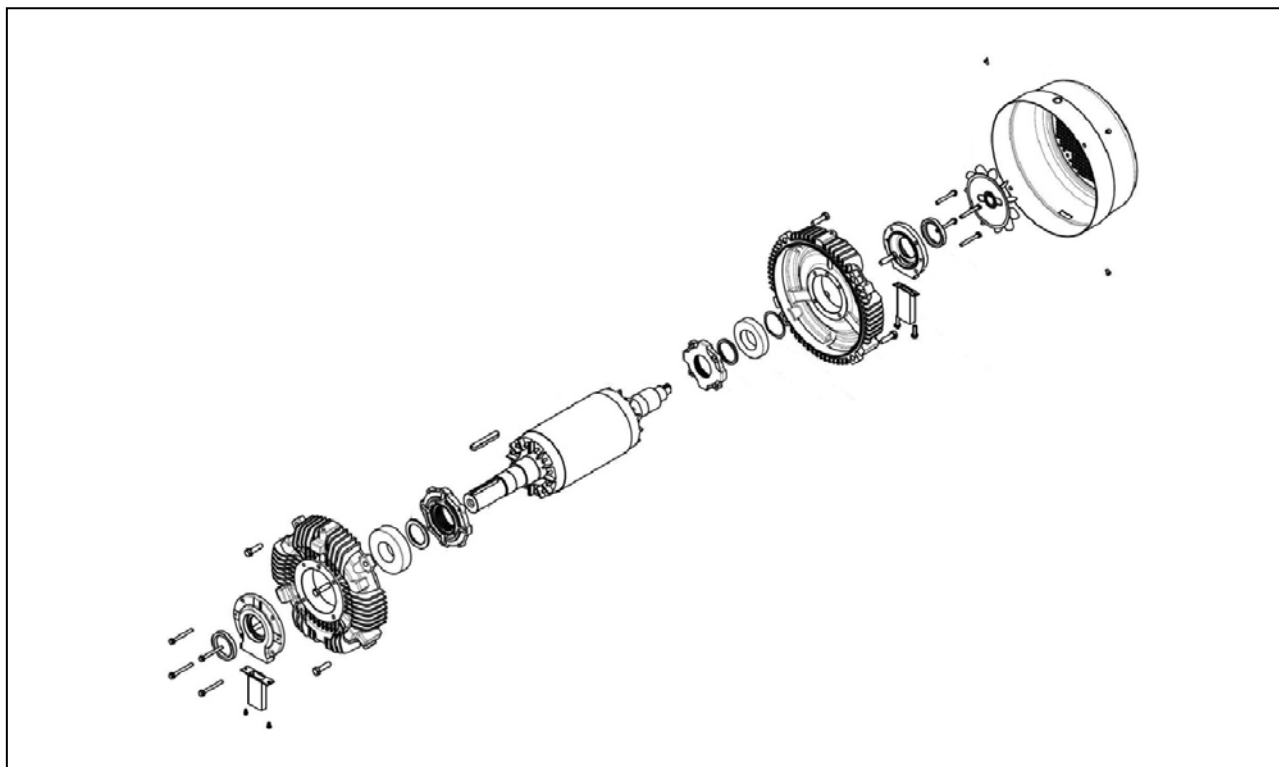

Figure 3-17: Rotor assembly (active part, shaft, bearings, end shields, fan)

The rotor is dynamically balanced with half key. The balance quality meets DIN ISO 1940, Q2,5. The mechanical vibrations of the motors meet level A according to EN 60034-14 at synchronous speed. Mechanical vibrations; permissible axial and radial forces at DE and maximum mechanical speed: Se 5.3 Mechanical performance, starting page 42.

3.4.2 Shaft

The dimensions of the DE shaft end (including the keyway) and their tolerances are standardized by IEC 60027-1 (DIN EN 50347). The DE shaft face has a threaded centre hole for mounting of customer's shaft fittings. The key is press fit into key way. The NDE shaft end is carrying the fan; on larger machines (see dimensional diagrams. Depending on frame size its face is equipped with a threaded centre hole for later mounting of accessories (like speed sensor, etc.). The fan is manufactured from conductive polypropylene (non-sparking material).

3.4.3 Bearings

As a standard both DE bearing and NDE bearing are ball bearings, suitable both for horizontal and vertical mounting of the motor (except for frame size 315, 2-pole; where a special bearing is provided for operation at vertical mounting, see tables below). As an option reinforced bearing types can be provided according to customer's load specifications.

The DE bearing is fixed; it absorbs axial and radial forces transmitted from the driven machine. The floating bearing is installed at the non drive end (NDE) to allow thermal expansion of the shaft and to absorb radial forces. The bearings are preloaded in axial direction by an undular washer at NDE. Even though the DE bearing is fixed due to a special design of the DE end shield it is easy to fit a flange end shield without removing the rotor. Disassembling of the rotor (e.g. for changing the terminal box position) can be carried out without disassembling the NDE).

Motors up to frame size 160 are equipped with double shielded bearings (suffix "zz" on bearing type). Those motors bearings are lubricated for life. They are maintenance-free and cannot be regreased.

Motors from frame size 180 up to frame size 315 are equipped with grease nipples both at DE and NDE for manual regreasing. These motors are already greased during manufacture. Grease nipples are of "flat button head" design according to DIN 3404 with thread M10 x 1. DE and NDE nipple are easily accessible (NDE nipple outside of the fan cowl).

Baugröße / Frame Size / Hauteur d'Arbre / Grandezza Motore / Carcasa / Размер двигателя	160	Polzahl / Poles / Poli / Polos / полюсов		Lagergröße / Bearing Size / Type de Roulement / Grandezza Cuscinetti / Tamaño Rodamiento / Размер подшипника		Nachschmierfrist [h] / Lubrication Interval [h] / Intervalle de Lubrification [h] / Intervallo Lubrificazione [h] / Intervalo Lubricación [h] / Периодичность замены смазки в подшипниках [ч]		Fettmenge [g] / Grease Quantity [g] / Quantité de Graisse [g] / Quantità di Grasso [g] / Cantidad de Grasa [g] / Количество смазки [г]		
		Standard		DE	NDE	DE	NDE	DE	NDE	
		2	6309 C3	6307 C3	3500	4200	25	13		
		4	6309 C3	6307 C3	8500	10500	25	13		
		6	6309 C3	6307 C3	14000	16000	25	13		
8	6309 C3	6307 C3	17500	21000	25	13				
Verstärkt/ Reinforced/ Renforcé/ Rinforzati/ Reforzado/ Усиленный										
4	NU309C3	6307 C3	3300	10500	25	13				
6	NU309C3	6307 C3	5100	16000	25	13				
8	NU309C3	6307 C3	7100	21000	25	13				
DE = Antriebsseitig/ Drive End/ Coté Arbre/ Anteriore/ Lado Acoplamiento/ Приводная сторона двигателя										
NDE = Lüftersseitig/ Non Drive End/ Coté Opposé à l'Arbre/ Posteriore/ Lado Op. Acoplamiento/ Непроводная сторона двигателя										
32045A0100005										

Figure 3-18: Regreasing sticker

A shaft lock is fitted on frame size 280 and 315 to prevent bearing damage during transportation.

Tables with the types of standard bearings and reinforced bearings (optional):

Frame size	Poles	Drive end	Non drive end	Remarks
63	2	6201 ZZC3	6201 ZZC3	Sealed bearings
	4	6201 ZZC3	6201 ZZC3	Sealed bearings
71	2	6202 ZZC3	6202 ZZC3	Sealed bearings
	4	6202 ZZC3	6202 ZZC3	Sealed bearings
	6	6202 ZZC3	6202 ZZC3	Sealed bearings
80	2	6204 ZZC3	6204 ZZC3	Sealed bearings
	4	6204 ZZC3	6204 ZZC3	Sealed bearings
	6, 8	6204 ZZC3	6204 ZZC3	Sealed bearings
90	2	6205 ZZC3	6205 ZZC3	Sealed bearings
	4	6205 ZZC3	6205 ZZC3	Sealed bearings
	6, 8	6205 ZZC3	6205 ZZC3	Sealed bearings
100	2	6206 ZZC3	6305 ZZC3	Sealed bearings
	4	6206 ZZC3	6305 ZZC3	Sealed bearings
	6, 8	6206 ZZC3	6305 ZZC3	Sealed bearings
112	2	6306 ZZC3	6306 ZZC3	Sealed bearings
	4	6306 ZZC3	6306 ZZC3	Sealed bearings
	6, 8	6306 ZZC3	6306 ZZC3	Sealed bearings
132	2	6308 ZZC3	6308 ZZC3	Sealed bearings
	4	6308 ZZC3	6308 ZZC3	Sealed bearings
	6, 8	6308 ZZC3	6308 ZZC3	Sealed bearings
160	2	6309 ZZC3	6309 ZZC3	Sealed bearings
	4	6309 ZZC3	6309 ZZC3	Sealed bearings
	6, 8	6309 ZZC3	6309 ZZC3	Sealed bearings

Table 3-5: Standard bearings used in aluminium motors (type code: ALAA....)

Frame size	Poles	Drive end				Non drive end	
		Sealed	Regreasable			Sealed	Regreasable
		Standard	Standard	Standard	Reinforced	Standard	Standard
		All mountings	B-mountings	V-mountings	All mountings	All mountings	All mountings
80	2	6204 ZZC3	nA	nA	nA	6204 ZZC3	nA
	4	6204 ZZC3	nA	nA	nA	6204 ZZC3	nA
	6, 8	6204 ZZC3	nA	nA	nA	6204 ZZC3	nA
90	2	6205 ZZC3	nA	nA	nA	6205 ZZC3	nA
	4	6205 ZZC3	nA	nA	nA	6205 ZZC3	nA
	6, 8	6205 ZZC3	nA	nA	nA	6205 ZZC3	nA
100	2	6206 ZZC3	nA	nA	nA	6206 ZZC3	nA
	4	6206 ZZC3	nA	nA	nA	6206 ZZC3	nA
	6, 8	6206 ZZC3	nA	nA	nA	6206 ZZC3	nA

Frame size	Poles	Drive end				Non drive end	
		Sealed	Regreasable			Sealed	Regreasable
		Standard	Standard	Standard	Reinforced	Standard	Standard
		All mountings	B-mountings	V-mountings	All mountings	All mountings	All mountings
112	2	6306 ZZC3	nA	nA	nA	6306 ZZC3	nA
	4	6306 ZZC3	nA	nA	nA	6306 ZZC3	nA
	6, 8	6306 ZZC3	nA	nA	nA	6306 ZZC3	nA
132	2	6308 ZZC3	nA	nA	nA	6306 ZZC3	nA
	4	6308 ZZC3	nA	nA	nA	6306 ZZC3	nA
	6, 8	6308 ZZC3	nA	nA	nA	6306 ZZC3	nA
160	2	6309 ZZC3	nA	nA	nA	6307 ZZC3	nA
	4	6309 ZZC3	nA	nA	nA	6307 ZZC3	nA
	6, 8	6309 ZZC3	nA	nA	nA	6307 ZZC3	nA

Table 3-6: Standard bearings used in cast iron motors (type code: ALCA...), frame size up to 160

Frame size	Poles	Drive end				Non drive end	
		Sealed	Regreasable			Sealed	Regreasable
		Standard	Standard	Standard	Reinforced	Standard	Standard
		All mountings	B-mountings	V-mountings	All mountings	All mountings	All mountings
180	2	nA	6311C3	6311C3	NU311	nA	6310C3
	4	nA	6311C3	6311C3	NU311	nA	6310C3
	6, 8	nA	6311C3	6311C3	NU311	nA	6310C3
200	2	nA	6312 C3	6312 C3	NU312	nA	6212 C3
	4	nA	6312 C3	6312 C3	NU312	nA	6212 C3
	6, 8	nA	6312 C3	6312 C3	NU312	nA	6212 C3
225	2	nA	6312 C3	6312 C3	NU312	nA	6212 C3
	4	nA	6313 C3	6313 C3	NU313	nA	6213 C3
	6, 8	nA	6313 C3	6313 C3	NU313	nA	6213 C3
250	2	nA	6313 C3	6313 C3	NU313	nA	6313 C3
	4	nA	6315 C3	6315 C3	NU315	nA	6313 C3
	6, 8	nA	6315 C3	6315 C3	NU315	nA	6313 C3
280	2	nA	6316 C3	6316 C3	NU316	nA	6314 C3
	4	nA	6318 C3	6318 C3	NU318	nA	6316 C3
	6, 8	nA	6318 C3	6318 C3	NU318	nA	6316 C3
315	2	nA	6316 C3	7316 C3	NU316	nA	6314 C3
	4	nA	6320 C3	6320 C3	NU320	nA	6316 C3
	6, 8	nA	6320 C3	6320 C3	NU320	nA	6316 C3
315D	2	nA	6316 C3	7316 C3	NU316	nA	6316 C3
	4	nA	6322 C3	6322 C3	NU322	nA	6322 C3
	6, 8	nA	6322 C3	6322 C3	NU322	nA	6322 C3

Table 3-7: Bearings used in cast iron motors (type code: ALCA...), frame size 180 up to 315

Bearing lifetime:

The calculated operating life L10 of the bearings is at least 20000 hours, provided:

- operation in horizontal position
- operation at nominal max temperature and nominal speed
- radial and axial forces are within the limits stated in the catalogue, refer to 5.3 "Mechanical performance", page 42.

In case of operation with a coupling (no additional axial or radial forces from the driven machine) a lifetime of 50000 h is calculated. Lifetime is reduced when operated at increased ambient temperature higher speed than nominal or under severe vibration conditions.

Tables for calculated operating lifetime:

Frame size	Lifetime at nominal operational conditions			
	2-pole	4-pole	6-pole	8-pole
	[h]	[h]	[h]	[h]
63	20000	40000	40000	40000
71	20000	40000	40000	40000
80	20000	40000	40000	40000
90	20000	40000	40000	40000
100	20000	40000	40000	40000
112	20000	40000	40000	40000
132	20000	40000	40000	40000
160	20000	40000	40000	40000

Table 3-8: Calculated lifetime for sealed standard bearings (operating life L10)

Sealing:

The sealing of DE and NDE bearing is provided by a radial seal ring with dust protection lip to fulfil the requirements of degree of protection "IP55". IP56 or IP65 protection options (dust tight; protection against powerful water jets) can be realized by reinforced sealing (see 3.4.3 Bearings, starting page 28). For applications with direct gearbox mounting an option "Oil Sealed Design" is available.

Bearing insulation:

If the motor is line operated (sinusoidal voltage supply) motors covered by this catalogue usually do not need a bearing insulation, because the shaft voltage (caused by small magnetic unbalance within the machine) does not exceed the level of 500 mV. This level is agreed as a save limit in the standard IEC 60034-17.

If the motor is inverter operated, increased bearing stress by high frequent bearing currents might occur. As an option TECO recommends using insulated bearing on NDE for frame size 280 and above in this case (see 5.5 Motor performance (inverter operated), starting page 51).

3.4.4 Regreasing

(relevant for cast iron motors, frame size 160–315)

Frame size	Regreasing intervals at nominal operational conditions [h], grease quantity per bearing [g]							
	2-pole		4-pole		6-pole		8-pole	
	DE	NDE	DE	NDE	DE	NDE	DE	NDE
160	4300 h	5800 h	1100 h	13000 h	16000 h	19000 h	2000 h	25000 h
	25 g	13 g	25 g	13 g	25 g	13 g	25 g	13 g
180	3500 h	3700 h	9000 h	9800 h	14000 h	15000 h	18000 h	19000 h
	40 g	30 g	40 g	30 g	40 g	30 g	40 g	30 g
200	3100 h	3700 h	8000 h	9000 h	12000 h	14000 h	17000 h	19000 h
	50 g	50 g	50 g	50 g	50 g	50 g	50 g	50 g
225	3100 h	3700	7200	8500	11000	13000	16000	17500
	65 g	30 g	65 g	30 g	65 g	30 g	65 g	30 g
250	2600 h	2600 h	6500 h	7200 h	10000 h	11000 h	15000 h	16000 h
	90 g	65 g	90 g	65 g	90 g	65 g	90 g	65 g
280	1800 h	2500 h	4700 h	6000 h	8500 h	9300 h	11800 h	12100 h
	100 g	80 g	120 g	100 g	120 g	100 g	120 g	100 g
315 S/M/L	1800 h	2500 h	4200 h	5500 h	7700 h	9300 h	11000 h	12100 h
	100 g	80 g	160 g	100 g	160 g	100 g	160 g	100 g
315 D	1800 h	1800 h	3600 h	3600 h	7000 h	7000 h	9500 h	9500 h
	100 g	100 g	220 g	220 g	220 g	220 g	220 g	220 g

Table 3-9: Regreasing intervals and grease quantity for motors with standard bearings; for nominal operation conditions at 50 Hz (data for motors operated at 60 Hz are available on request).

Frame size	Regreasing intervals at nominal operational conditions [h], grease quantity per bearing [g]							
	2-pole		4-pole		6-pole		8-pole	
	DE	NDE	DE	NDE	DE	NDE	DE	NDE
160	n.a.	n.a.	3300 h	10500 h	5100 h	16000 h	7100 h	21000 h
	n.a.	n.a.	25 g	13 g	25 g	13 g	25 g	13 g
180	n.a.	n.a.	3700 h	9800 h	6500 h	15000 h	1900 h	17000 h
	n.a.	n.a.	40 g	30 g	40 g	30 g	40 g	30 g
200	n.a.	n.a.	3600 h	9000 h	6200 h	14000 h	8200 h	19000 h
	n.a.	n.a.	50 g	50 g	50 g	50 g	50 g	50 g
225	n.a.	n.a.	3300 h	8500 h	5800 h	13000 h	7600 h	17500 h
	n.a.	n.a.	65 g	30 g	65 g	30 g	65 g	30 g
250	n.a.	n.a.	2800 h	7200 h	4600 h	11000 h	7000 h	16000 h
	n.a.	n.a.	90 g	65 g	90 g	65 g	90 g	65 g
280	n.a.	n.a.	2250 h	6000 h	3800 h	9300 h	5500 h	12100 h
	n.a.	n.a.	120 g	100 g	120 g	100 g	120 g	100 g
315 S/M/L	n.a.	n.a.	1900 h	5500 h	3400 h	9300 h	4500 h	12100 h
	n.a.	n.a.	160 g	100 g	160 g	100 g	160 g	100 g
315 D	n.a.	n.a.	1800 h	3600 h	3200 h	7000 h	4500 h	9500 h
	n.a.	n.a.	220 g	220 g	220 g	220 g	220 g	220 g

Table 3-10: Regreasing intervals and grease quantity for motors with reinforced bearings; for nominal operation conditions at 50 Hz (data for motors operated at 60 Hz are available on request).

The grease must be replaced at regular intervals depending on the motor size and its usage. The used grease exits through a grease drain. Regreasing intervals and grease quantity: see tables Table 3-9 and Table 3-10 and regreasing labels on the motor.

Regard that greasing intervals are given for operation at rated speed, nominal operation conditions and for horizontal mounting position. In case of vertical use the intervals shall be reduced to 50 %. In case of ambient temperature higher than 40 °C or when operated with higher speed than nominal the intervals have to be reduced according table below:

Ambient temperature	+40 °C	+50 °C	+60 °C
Recommended reduction of regreasing intervals	1	0,6	0,4

Continuous speed	nominal	1,5 x nominal	2 x nominal
Recommended reduction of regreasing intervals	1	0,6	0,5

Table 3-11: Rule of thumb for reduction of regreasing intervals

Details (grease type, recommendations for greasing procedure) can be seen on additional regreasing nameplates (close to the regreasing nipples) and the TECO manual "INSTALLATION, OPERATION and MAINTENANCE INSTRUCTIONS".

3.5 Degree of protection

The IEC classification system IEC 60034-5 defines the protection against external influence, e.g. degree "IP55". The first numeral describes the protection of people against contact with live parts and rotating parts and the protection against ingress of dust. The second numeral defines the protection against ingress of water.

As a standard the motors comply with degree IP55; this describes:

- The machine is completely protected against contact with live or rotating parts. Ingress of dust is not totally prevented, but dust does not enter in sufficient quantity to interfere with satisfactory operation of the machine.
- The machine is protected against water jets. Water projected by a nozzle against the machine from any direction has no harmful effect. (Remark: Restrictions concerning fan, degree IP20, and the shaft end are covered by standards).

This allows the operation of the motor in a rough environment.

In outdoor application the motor shall be protected against excessive solar radiation.

The motors are intended for use in a "Safe Area". Operation in "Hazardous Area" is not permitted.

Optionally IP56 or IP66 (dust tight; protection against powerful water jets) can be realized by reinforced sealing (see 3.4.3 Bearings, starting page 28).

3.6 Others

3.6.1 Grounding terminals

The grounding terminals are directly screwed into the motor frame and have no other function except of grounding, they comply with EN 60 204-1. Screws, washers and U-clamps are made of electro-zinc plated steel. They are labelled with the ground symbol defined in DIN EN 60 617-2: One terminal is located inside of the terminal box. The stator housing provides 4 external access points for grounding to allow easy access in every possible mounting position. The assembled grounding access point shall be free of primer or paint and shall be metallic blank. Only 1 access points is finally assembled ex factory (right hand side).

Design examples for grounding terminals:

- a) for motors frame size 80...250
- b) for motors frame size 280 and larger

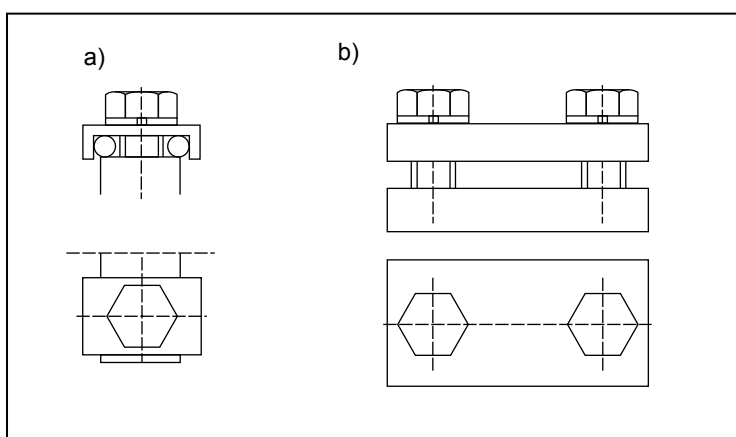

Figure 3-19: Design examples for grounding terminals

3.6.2 Lifting eyes

Using the lifting eye(s) is obligatory when transporting and lifting the motor; details see TECO manual “INSTALLATION, OPERATION and MAINTENANCE INSTRUCTIONS”. The position of the lifting eye(s) can be seen in the sample figure below and in section 7 Outline drawings, starting page 82. In case of 2 lifting eyes (frame size 132 and larger) both of the 2 lifting eyes have to be used. They are located in a way that there is no collision with already installed power cables installed in axial direction.



Figure 3-20: Position of lifting eyes

3.6.3 Drain holes

As a standard no drain holes are provided. Drain holes can be drilled on customer's request for frame size 132 and larger. They will be located in the brackets or flanges and not in the housing to allow later modifications of the mounting arrangement.

3.6.4 SPM provision

Drilled, tapped and plugged holes with conical M8 thread for later shock pulse measurement nipple mounting on DE and NDE are provided for frame size 280 and above.

3.6.5 Painting, corrosion protection

Concerning corrosion the top coat is resistant to water, steam and salt water. Concerning chemical surrounding the top coat is resistant to hydraulic liquids, cleaning agents, synthetic coolants, solvents and chemicals. The coating is appropriate for a temperature range from $-40\text{ }^{\circ}\text{C}$ to $+130\text{ }^{\circ}\text{C}$; it stays nonabrasive, elastic, scratch resistant and impact resistant through the whole temperature range. The motors are suitable for use in paint shops and are 100 % free of paint adhesion detrimental substances as for example silicone. Layer thickness see figure below.

	Cast iron, frame size ≤ 132 Aluminium motors ≤ 160	Cast iron, frame size ≥ 160
Primer for cast iron parts	min. 20 μm	min. 25 μm
Primer for aluminium parts	min. 20 μm	—
Primer for steel parts	min. 20 μm	min. 25 μm
Base prior to top coat	min. 20 μm	min. 50 μm
Top coat *	min. 20 μm	min. 25 μm
Total thickness of coating	min. 60 μm	min. 100 μm

*) The inner surface of the fan cowl is treated with primer only.

Table 3-12: Layer thickness of painting

As a standard the motor frame and fan cowl colour is grey (RAL 7032, pebble grey). For later customizing of the motor it is possible to spray a second layer of top coat (same thickness as standard coating) without influence to the thermal design of the motor.

All machined and metallic blank surfaces (feet, flange, 1 external grounding surface, shaft end) are protected against corrosion. The antirust agent can stay at the parts without influence to customer assembling (coupling) or mounting the motor to machine (max. layer thickness 5 µm).

3.6.6 Rating plate and labelling

The material of the rating plate is stainless steel and the data indicated are irremovable and clearly engraved or lasered. It is irremovably fixed (riveted) at the motor frame.

Rating plate data comply with IEC 60 034-1 and contain e.g. (see sample below):

- name of manufacturer
- serial number (a unique individual identification number) and year of construction
- reference to IEC standard
- efficiency level (efficiency class IE-code according to IEC 60 034-30)
- the CE marking
- technical data according to IEC 60 034-1.

The Rating plate is split into 2 sections, mounted on a common plastic base plate. The plastic base plate and the main section (bottom) of the rating plate are riveted to the motor frame. The upper section is solely wearing the manufacturer's brand and is clipped into the plastic base plate. As a standard it will carry the TECO-Brand; optionally with customer's brand instead. For original equipment manufacturers it is possible to remove the original brand plate easily and to clip an individual brand plate into the plastic base plate in site.



Figure 3-21: Sample of a TECO rating plate

Additional nameplates and markings:

- Connection diagram sticker with the wiring diagram, fitted on the inside of the terminal box lid
- In case of optional accessories: connection diagram sticker inside terminal box
- Grounding symbols according to DIN EN 60617-2
- In case of regreasable bearings: regreasing nameplates (close to the regreasing nipples)

4 Electrical design

Squirrel cage motors as covered by this catalogue provide electrical active parts:

- **Rotor**
The active part is a rugged arrangement only consisting of the magnetic lamination and the short circuit “winding” made of cast aluminium embedded in slots.
- **Stator**
Contains the magnetic stator lamination, the three phase winding embedded in slots; including its insulation system and integrated temperature sensors.
- **Terminals**

4.1 Stator winding

The stator winding is carried out as a wire wound winding (“random winding”). High quality enamelled wires are used. Insulating sheets provide proper performance for

- insulation phase to ground,
- insulation phase to phase and
- interturn insulation.

An appropriate phase separation and a proper bandage of the winding overhang ensure high electric and mechanical strength. The stator winding is rotating dip impregnated with varnish or resin according to “thermal class F” requirements. According to the classification EN 60085 thermal class F allows a maximum hot spot temperature of 155 °C. TECO motors covered by this catalogue are utilized (under nominal conditions) according to class “B”:

- average temperature rise (by resistance method) is 80 °K;
- maximum spot temperature is 130 °C.

This ensures a high lifetime of the insulation system. (Insulation does not suddenly fail if the maximum temperature of the thermal class is reached, but useful operating life declines rapidly. A rule of thumb is a halving of life time for every increase of 10 °C.) As an option an additional finish for tropical protection (against fungus) can be provided (option “Tropical Climate Proof”).



Figure 4-1: Stator core with winding



Figure 4-2: Stator core with slot liners

The winding features 3 phases which produce the rotating magnetic flux. All 6 winding ends are connected to the terminal box. The 3-phase line can be connected to the winding either in star connection (written as “Y”) or delta connection (written as “D” or Δ), see figure below:

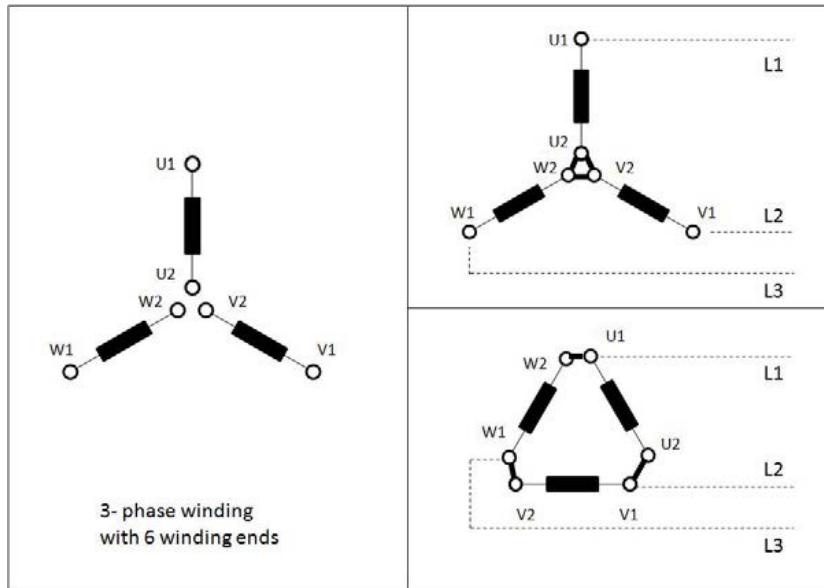

Figure 4-3: Three phase stator winding (star and delta connection)

These configurations allow operation of a certain motor at a higher line voltage level (e.g. 690 V with “star” connection) or at a lower line voltage (e.g. 400 V with “delta” connection). In case of dual rating: The rating plate is providing data for both applications (e.g.: “400 V/690 V D/Y; 129,4 A/75 A”).

If the standard configuration of the motor for nominal voltage is designed as “delta” (preferred at higher power rating) the motor might be switched to “star” during starting by an external switchgear. This allows reduction of starting current (factor $\sqrt{3}$) and starting torque (factor 3).

The TECO standard configuration is shown in the table below:

Power rating [kW]	Line frequency [Hz]	Nominal voltage [V]; connection
≤ 2.2	50	230 V Δ / 400 V Y
	60	265 V Δ / 460 V Y
≥ 3.0	50	400 V Δ / 690 V Y
	60	460 V Δ

Table 4-1: TECO standard winding configuration and nominal voltage(s)

The configuration can be carried out by the user by inserting the jumpers of the terminal box; the spatial arrangement is shown in the figure below (standard sticker inside of the terminal box):

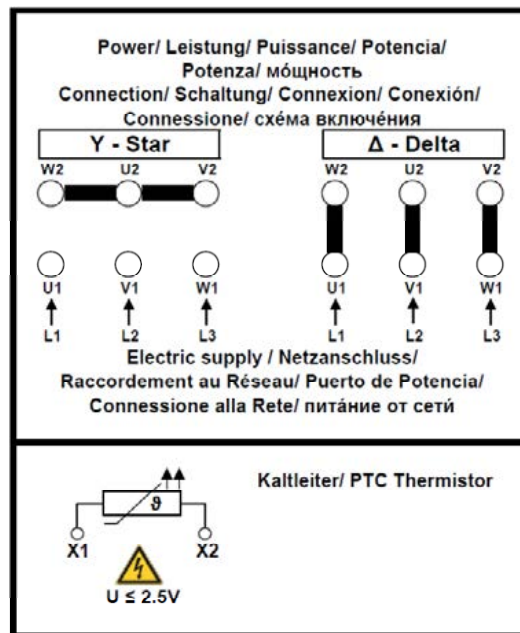

Figure 4-4: Arrangement of connection bolts and jumpers for star/delta connection

Phase sequence:

If the terminals are connected to an electrically clockwise supply system the motor is designed for clockwise mechanical rotation (when viewing from driving shaft end; according to IEC 60 034-8). For change of rotational direction a change of 2 supply line phases has to be carried out by customer.

4.2 Thermal protection

For thermal protection of the winding as a standard 3 temperature PTC thermistors are embedded in the winding; one for each phase (acc to standards IEC 60 034-11 and DIN 44081). Their nominal temperature level is 150 °C; when reaching this temperature their resistance suddenly escalates to a high level. They are connected in series and lead to terminals in the terminal box. A suitable monitoring device according to standard DIN 44081 shall be connected by customer and shall be used for tripping the system.

At inverter operation the use of this method of thermal protection is mandatory; protection measures based on operating current are not suitable in this case. A warning on the sticker inside the terminal box shows that no voltage higher than 2,5 V must be applied on these terminals.

5 Performance data

5.1 Duty type

The motors are designed for continuous operation at full load under nominal ambient conditions (duty type “S1” according to IEC 60034-1. Type data for differing duty types (S2...S8, periodic variation of load, influence of frequent starting stress, etc.) and S9 (non-periodic load and speed variation, e.g. at inverter operation) can be evaluated on request.

5.2 Environmental conditions, performance

All environmental conditions in site as listed in standard IEC 60721-3 (temperature, altitude, exposition to water, biological, chemical and mechanical active substances, vibrations, etc. have to be in accordance with the design of the motor (e.g. degree of protection).

5.2.1 Operation at high ambient temperature/high altitude

As a standard the motors are designed for

- ambient temperature (cooling air temperature): -20 °C up to $+40\text{ °C}$
- maximum altitude 1000 m above sea level

The motors can also be operated at higher ambient temperatures or at higher altitude if the continuous output power is reduced, see figures below. In this case the winding temperature rise is approximately identical to nominal operation. It has to be regarded that the bearing stress at higher temperature is increased and regreasing intervals shall be shortened accordingly then (see 3.4.3 Bearings, starting page 28).

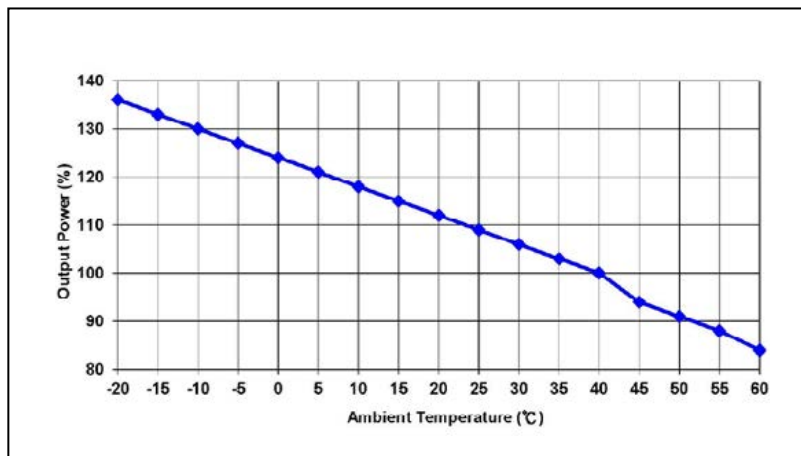

Figure 5-1: Reduction of output power versus ambient temperature

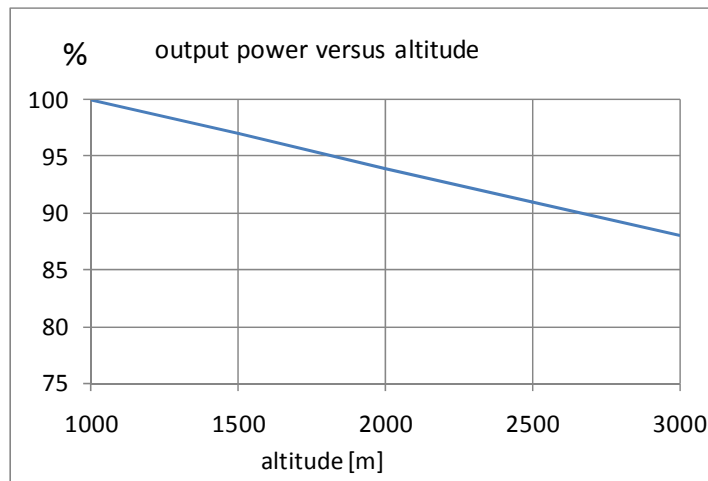

Figure 5-2: Reduction of output power versus altitude

Output with nominal power rating is permissible at high altitude, if accordingly the ambient temperature is reduced, see figure below:

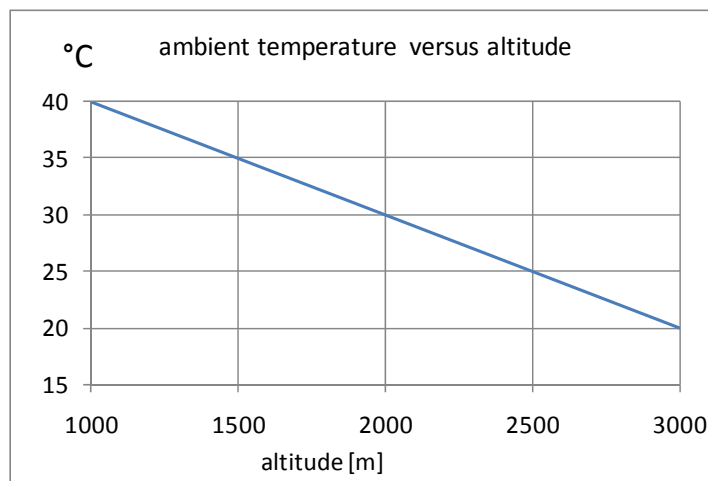

Figure 5-3: Reduction of ambient temperature versus altitude for nominal output rating

5.2.2 Operation at low temperature/high humidity

For operation at ambient temperature range $-20\text{ }^{\circ}\text{C}$ to $+40\text{ }^{\circ}\text{C}$ a heater for the motor winding is necessary at standstill. The same precaution is requested for operation in sites with normal temperature level, but high humidity (typically above 90 %) to prevent condensation inside the motor.

Heating can be carried out:

- By accessory "Heating via strip heater"
In this case additional terminals for the heater are provided within the terminal box. Heater terminals are marked with a voltage flash and a short note "Heater may be energized even if motor is isolated!" A special connection diagram sticker with the wiring diagram of the accessory is fitted inside terminal box lid.
Approx. heater power see Table 5-1, page 42.
- By heating the motor via stator winding. An auxiliary single phase AC voltage supply is to be connected to 2 power connectors. The appropriate voltage level and VA-rating depending on the motor size: On request. The safety precautions as mentioned above have to be regarded by the user.

Frame size	To prevent condensation			For ambient temperature -20 °C to -40 °C		
	Heater output [W]	Heater nominal voltage single phase AC [V]		Heater output [W]	Heater nominal voltage single phase AC [V]	
		230	400		230	400
63	10	10	10	10	10	10
71	10	10	10	10	10	10
80	20	20	20	20	20	20
90	20	20	20	20	20	20
100	30	30	30	30	30	30
112	30	30	30	30	30	30
132	40	40	40	40	40	40
160	40	40	40	40	40	40
180	50	50	50	50	50	50
200	50	50	50	50	50	50
225	60	60	60	60	60	60
250	60	60	60	60	60	60
280	150	150	150	150	150	150
315	200	200	200	200	200	200

Table 5-1: Availability and output power of option "Heating via Strip Heater"

5.2.3 Operation at severe mechanical conditions

For operation at extraordinary mechanical conditions (permanent exposure to vibration and shock higher than class 3M3 acc. to IEC 60721-3) we recommend a special request.

5.3 Mechanical performance

5.3.1 Torque characteristic; starting performance

The power rating (nominal power P_N) and the nominal torque (T_N) of each type is listed in 6 Technical data, starting page 58. The torque can be calculated in general as:

$$T = \frac{9550 \times P}{n}$$

where T = torque [Nm]
 P = power [kW] and
 n = speed [rpm].

The motors are equipped with a squirrel cage rotor (cast aluminium); they are suitable for direct starting. Direction of rotation is clockwise (view onto shaft end) if a clockwise supply system is connected according to the wiring diagram. Technical data of the standard motors are valid for both directions of rotation (bidirectional design). In IEC 600034-12 the starting performance is standardized.

During starting the motor creates a torque according to its individual characteristic (locked rotor torque, pull up torque and break down torque as generally described in 1.2.7 Performance characteristics: Speed, torque, starting page 11). Depending on the type an individual value for the torques is listed in 6 Technical data, starting page 58. A sample of a

TECO type test see figure below. In steady operation at full load torque the individual nominal speed (close to no load speed) is reached. It has to be regarded that this speed is only valid for thermal equilibrium conditions. If the motor is not heated up this speed will be significant closer to the no load speed. Limits and tolerances according to IEC standard: see 6.1 General data; tolerances (acc. to IEC 60034-1), starting page 58.

According to requirements of IEC 60034 the break down torque (including -10 % tolerance) has to be 160 % at least. The torque values are quadratic depending on a variation of line voltage. (Correspondingly the complete torque characteristic e.g. is reduced by a factor of 3 when starting the motor in star-delta).

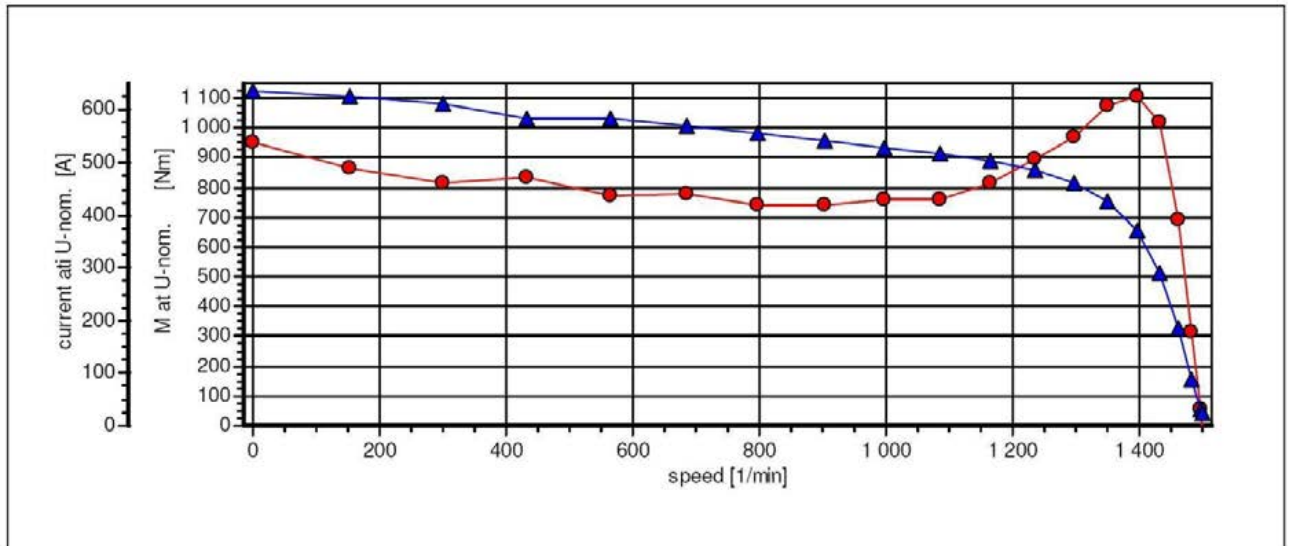

Figure 5-4: Sample of TECO type test data sheet: Torque and current vs. speed

5.3.2 Maximum operational speed

It is possible to increase the speed e.g. by feeding the motor from a frequency inverter with increased frequency. In general it shall be regarded at increased speed (also see 5.5 Motor performance (inverter operated), starting page 51):

- increase of acoustic noise level (especially contribution of fan noise)
- increase of vibration
- greasing intervals shall be shortened accordingly then (see 3.4.3 Bearings, starting page 28)
- bearing life may be reduced
- maximal mechanically permissible operational speed limit, see table below, following the requirements of IEC 60034-1; both for horizontal and vertical mounting:

Frame size	2-pole		4-pole		6-pole		8-pole	
	[min ⁻¹]	[Hz]	[min ⁻¹]	[Hz]	[min ⁻¹]	[Hz]	[min ⁻¹]	[Hz]
63	5200	87	3600	120	2400	120	1600	106
71	5200	87	3600	120	2400	120	1600	106
80	5200	87	3600	120	2400	120	1600	106
90	5200	87	3600	120	2400	120	1600	106
100	5200	87	3600	120	2400	120	1600	106
112	5200	87	3600	120	2400	120	1600	106
132	4500	75	2700	90	2400	120	1600	106
160	4500	75	2700	90	2400	120	1600	106
180	4500	75	2700	90	2400	120	1600	106
200	4500	75	2300	77	1800	90	1200	80
225	3600	60	2300	77	1800	90	1200	80
250	3600	60	2300	77	1800	90	1200	80
280	—	—	—	—	—	—	—	—
315	—	—	—	—	—	—	—	—

Table 5-2: Maximal permissible operational speed

5.3.3 Permissible radial shaft forces

At operation with belt drive (or caused by other influences of the driven equipment) radial forces will impact on shaft end and bearings. For belt drives a rough estimation of the radial force can be carried out:

$$F_r \cong \frac{5000 \times P}{D \times n}$$

where F_r = radial force [N]
 P = power rating [kW]
 D = diameter of pulley [m] and
 n = speed [rpm].

The permissible radial force depends on the axial point of application of the external force, see figure below:

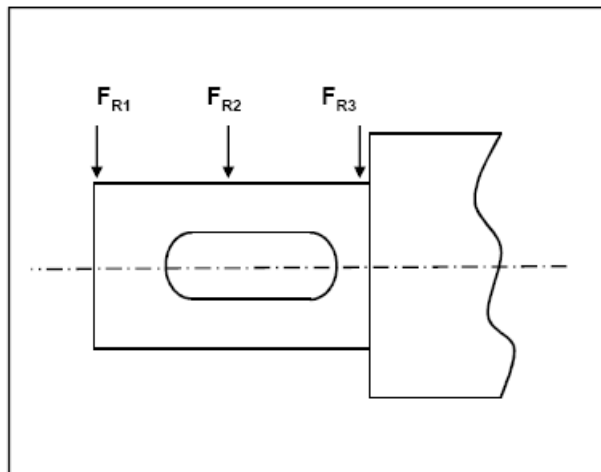

Figure 5-5: Axial point of application of the external radial force

The permissible radial thrust is given in the table below:

- for standard ball bearings and
- for optional version with cylinder roller bearings.

It has to be regarded that cylinder roller bearings demand a minimum radial force for proper operation.

Radial bearing load F_R [N]											
		Load F_R for standard ball bearings				Load F_R for cylinder roller bearings					
		Aluminium motors			Cast iron motors			Cast iron motors			
		Max.	Max.	Max.	Max.	Max.	Max.	Max.	Max.	Max.	Min.
Frame size	poles	F_{R1}	F_{R2}	F_{R3}	F_{R1}	F_{R2}	F_{R3}	F_{R1}	F_{R2}	F_{R3}	$F_{R3 \text{ min}}$
63	2				n.a.	n.a.	n.a.	n.a.	n.a.	n.a.	n.a.
	4				n.a.	n.a.	n.a.	n.a.	n.a.	n.a.	n.a.
	6				n.a.	n.a.	n.a.	n.a.	n.a.	n.a.	n.a.
	8				n.a.	n.a.	n.a.	n.a.	n.a.	n.a.	n.a.
71	2				n.a.	n.a.	n.a.	n.a.	n.a.	n.a.	n.a.
	4				n.a.	n.a.	n.a.	n.a.	n.a.	n.a.	n.a.
	6				n.a.	n.a.	n.a.	n.a.	n.a.	n.a.	n.a.
	8				n.a.	n.a.	n.a.	n.a.	n.a.	n.a.	n.a.
80	2				558	620	682	n.a.	n.a.	n.a.	n.a.
	4				699	777	855	n.a.	n.a.	n.a.	n.a.
	6							n.a.	n.a.	n.a.	n.a.
	8							n.a.	n.a.	n.a.	n.a.
90	2				583	659	736	n.a.	n.a.	n.a.	n.a.
	4				741	838	936	n.a.	n.a.	n.a.	n.a.
	6				849	961	1073	n.a.	n.a.	n.a.	n.a.
	8							n.a.	n.a.	n.a.	n.a.
100	2				830	932	1034	n.a.	n.a.	n.a.	n.a.
	4				1039	1168	1296	n.a.	n.a.	n.a.	n.a.
	6				1186	1333	1479	n.a.	n.a.	n.a.	n.a.
	8							n.a.	n.a.	n.a.	n.a.
112	2				1157	1293	1429	n.a.	n.a.	n.a.	n.a.
	4				1465	1637	1809	n.a.	n.a.	n.a.	n.a.
	6				1699	1898	2098	n.a.	n.a.	n.a.	n.a.
	8							n.a.	n.a.	n.a.	n.a.
132	2				1734	1970	2207	n.a.	n.a.	n.a.	n.a.
	4				2185	2428	2780	n.a.	n.a.	n.a.	n.a.
	6				2530	2834	3139	n.a.	n.a.	n.a.	n.a.
	8							n.a.	n.a.	n.a.	n.a.
160	2				2198	2507	2816				
	4				2740	3125	3511				
	6				3143	3541	3938				
	8										
180	2	n.a.	n.a.	n.a.	3141	3529	3917	6669	7407	8327	919
	4	n.a.	n.a.	n.a.	3835	4316	4796	8027	8920	10036	804
	6	n.a.	n.a.	n.a.	4398	4902	5405	9186	10135	11302	766
	8	n.a.	n.a.	n.a.							
200	2	n.a.	n.a.	n.a.	3434	3793	4152	7350	8119	8888	1108
	4	n.a.	n.a.	n.a.	4368	4825	5282	9075	10024	10973	960
	6	n.a.	n.a.	n.a.	4965	5485	6004	10203	11271	12338	911
	8	n.a.	n.a.	n.a.							
225	2	n.a.	n.a.	n.a.	4010	4401	4792	8233	9036	9839	1316
	4	n.a.	n.a.	n.a.	4731	5346	5962	9503	10739	11976	1131
	6	n.a.	n.a.	n.a.	5436	6112	6788	10817	12161	13506	1069
	8	n.a.	n.a.	n.a.							
250	2	n.a.	n.a.	n.a.	4902	5441	5981	11585	12860	14135	1807
	4	n.a.	n.a.	n.a.	6026	6685	7343	14149	15695	17240	1525
	6	n.a.	n.a.	n.a.	7130	7909	8688	16194	17963	19732	1431
	8	n.a.	n.a.	n.a.							
280	2	n.a.	n.a.	n.a.	5231	5685	6224	11638	12656	13856	2092
	4	n.a.	n.a.	n.a.	7482	8255	9210	17635	19451	21692	2241
	6	n.a.	n.a.	n.a.	8353	9210	10275	19671	21705	24216	2082
	8	n.a.	n.a.	n.a.							
315 L	2	n.a.	n.a.	n.a.	5208	5514	5871	12114	12827	13642	2094
	4	n.a.	n.a.	n.a.	8895	9786	10894	22106	24348	27100	2910
	6	n.a.	n.a.	n.a.				24996	27531	30640	2679
	8	n.a.	n.a.	n.a.							

Table 5-3: Permissible radial shaft forces

5.3.4 Permissible axial shaft forces

The permissible external forces in axial direction (direction towards DE or towards NDE) is depending on the mounting position of the motor:

- horizontal shaft,
- shaft up or
- shaft down.

The figures refer to standard bearing design (reinforced version on request) and operation at nominal speed or horizontal mounting; e. g. mounting B3, B5, B6, B7, B8, B14, B34, B35:

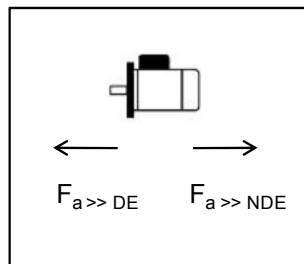

Figure 5-6: Mounting position "horizontal" and directions of axial force

Frame size	Maximal axial bearing load F_a [N]							
	2-pole		4-pole		6-pole		8-pole	
	$F_a \gg NDE$	$F_a \gg DE$	$F_a \gg NDE$	$F_a \gg DE$	$F_a \gg NDE$	$F_a \gg DE$	$F_a \gg NDE$	$F_a \gg DE$
	←	→	←	→	←	→	←	→
63								
71								
80	490	490	617	617				
90	470	470	676	676	774	774		
100	657	657	931	931	1068	1068		
112	911	911	1294	1294	1490	1490		
132	1401	1401	1960	1960	2254	2254		
160	1793	1793	2528	2528	2881	2881		
180	2470	2470	3440	3440	3920	3920		
200	2734	2734	3459	3459	4449	4449		
225	3165	3165	3920	3920	5018	5018		
250	3900	3900	4753	4753	6233	6233		
280	4106	4106	6085	6085	6860	6860		
315 S/M	3775	3775	6694	6694	7577	7577		
315 L	3645	3645	6713	6713	7693	7693		

Table 5-4: Maximal permissible axial bearing load for mounting position "horizontal"

5.3.5 Vibration

The motors are dynamically balanced with half key and the shaft end face is marked according to standard DIN ISO 8821 (marking “H” = half key). The balance quality meets DIN ISO 1940, Q2,5.

The mechanical vibrations of the motors meet level A according to EN 60034-14 at synchronous speed; standardized limits see table below (special design like full-key-balancing, no-key-balancing or vibration grade B on request.)

Frame size		56 to 132		160 to 280		> 280	
		Displac.	Veloc.	Displac.	Veloc.	Displac.	Veloc.
	Mounting	[µm]	[mm/s] RMS	[µm]	[mm/s] RMS	[µm]	[mm/s] RMS
Vibration Grade A	Free suspension	25	1.6	35	2.2	45	2.8
	Rigid mounting	21	1.3	29	1.8	37	2.3
Vibration Grade B	Free suspension	11	0.7	18	1.1	29	1.8
	Rigid mounting	n.a.	n.a.	14	0.9	24	1.5

Grade “A” applies to machines with no special vibration requirements;
Grade “B” applies to machines with special vibration requirements.

Table 5-5: Vibration limits according to IEC 60034-14

5.4 Motor performance (line operated)

The motors covered by this catalogue are low voltage asynchronous motors; designed for operation at a three phase AC voltage system (depending on the type; availability see 4.1 Stator winding, starting page 37):

- 230 V, 3 AC, 50 Hz,
- 400 V, 3 AC, 50 Hz,
- 690 V, 3 AC, 50 Hz, according to IEC 60038 and DIN IEC 60 038
- 265 V, 3 AC, 60 Hz,
- 460 V, 3 AC, 60 Hz.

The motors are designed for efficiency class IE2 (aluminium motors) and for both IE2 and IE3 (cast iron motors).

5.4.1 Requirements for supply voltage and frequency

Permissible tolerances of voltage and frequency at operation IEC 60034-1 defines 2 ranges of permissible variation of voltage and frequency, “Zone A” and “Zone B”, see figure below:

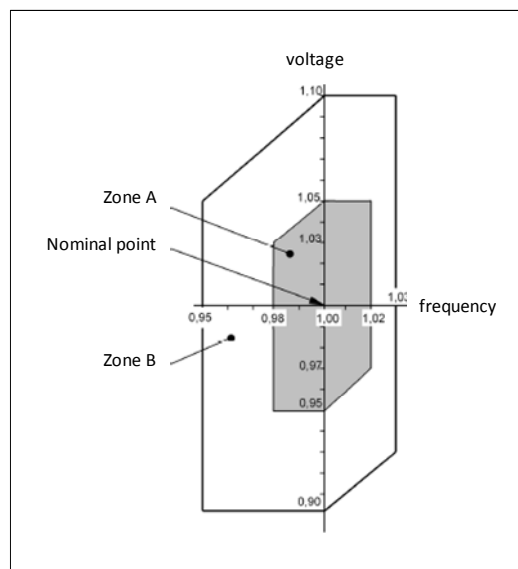

Figure 5-7: Permissible tolerance of voltage and frequency acc. to IEC 60034-1

“Zone A”:

According to IEC 60034-1 the motor is suitable to perform its nominal torque continuously. The performance characteristics may have deviations from the nominal values and the temperature rise is higher than nominal.

“Zone B”:

(continuous operation is explicitly not recommended by IEC 60034-1): The motor is suitable to perform its nominal torque continuously. The performance characteristics may have greater deviations from the nominal values; the temperature rise is higher than within “Zone A”.

Requirements for waveform and unbalance of the supply voltage: Distortion of the sinusoidal waveform (caused by neighbouring power electronics) and unbalance of the voltage system (e.g. caused by single-phase loads) is permissible within the limits given in IEC 60034-1 section 7.2.1.1 (distortion factor HVF < 3 % and negative sequence component < 1 %).

Special requirements (voltage peaks) have to be observed at inverter operation: see 5.5 Motor performance (inverter operated), starting page 51.

5.4.2 Current, power factor and efficiency at partial load

The general characteristic is shown in section 1 (e.g. Figure 1-4, page 13).

Type specific data for TECO motors:

- Values for the nominal point can be seen on the rating plate and in 6 Technical data, starting page 58.
- Values for partial load (power factor and efficiency) can be seen in 6 Technical data, starting page 58, columns 1/4, 2/4 and 3/4 partial load.

Overload capability according to IEC 60034-1 section 9:

- 150 % of nominal current during 2 min. at least;
- Min. 160 % of full load torque for 15 sec.

5.4.3 Current during starting, limitations

General characteristic: see 1.2 Basics, terms and definitions, starting page 9 (sample for a TECO type test protocol: see Figure 5-4, page 43). Type specific data for TECO motors are evaluated during type test and are available on request.

Overload capability:

A minimum of overload capability is defined in IEC 60034-1 section 9:

- Min. 2 min. at 150 % of nominal current (for motors with power rating up to 315 kW);
- Min. 160 % of full load torque for 15 sec.

Locked rotor:

The motors are suitable for direct starting; however the high current during starting causes a high thermal load for the stator winding and especially for the rotor.

A maximum locked rotor time has to be regarded, depending on the type. The table below shows the max. duration when starting at cold machine and at nominal operation temperature:

Nominal power [kW]	Maximum locked rotor time [s]: 50 Hz; cast iron; IE2 version (n.a. = not available)							
	2-pole		4-pole		6-pole		8-pole	
	Cold	Hot	Cold	Hot	Cold	Hot	Cold	Hot
0.18	n.a.	n.a.	n.a.	n.a.	n.a.	n.a.	102.9	51.4
0.25	n.a.	n.a.	n.a.	n.a.	n.a.	n.a.	95.2	47.6
0.37	n.a.	n.a.	n.a.	n.a.	53.3	26.7	116.9	58.4
0.55	n.a.	n.a.	39.2	19.6	73.0	36.5	82.0	41.0
0.75	17.3	8.6	37.4	18.7	61.9	30.9	57.0	28.5
1.1	11.1	5.6	30.4	15.2	47.4	23.7	52.8	26.4
1.5	10.8	5.4	25.9	13.0	45.9	23.0	41.5	20.8
2.2	10.2	5.1	23.3	11.7	29.5	14.7	23.1	11.6
3	10.1	5.0	20.9	10.5	28.9	14.5	20.8	10.4
4	16.6	8.3	14.4	7.2	25.2	12.6	40.2	20.1
5.5	10.5	5.3	17.8	8.9	22.9	11.5	32.0	16.0
7.5	10.2	5.1	11.4	5.7	19.3	9.7	32.7	16.4
11	18.5	9.2	15.9	7.9	17.4	8.7	25.4	12.7
15	14.1	7.0	12.3	6.2	24.1	12.1	31.2	15.6
18.5	15	7.5	37.1	18.5	31.9	15.9	51.8	25.9
22	18.8	9.4	29.9	14.9	31.7	15.8	53.4	26.7
30	22.0	11.0	17.2	8.6	34.3	17.1	41.6	20.8
37	18.9	9.5	26.3	13.1	38.6	19.3	30.9	22.1
45	20.4	10.2	21.3	10.7	19.7	14.1	27.7	19.8
55	24.9	12.4	19.9	9.9	19.9	14.2	20.6	14.7
75	13.4	9.6	10.4	7.4	18.2	13.0	19.0	13.6
90	11.9	8.5	8.5	6.1	15.5	11.1	18.3	13.1
110	14.0	10.0	10.5	7.5	16.2	11.6	17.9	12.8
132	12.9	9.2	9.1	6.5	16.1	11.5	14.1	10.1

Maximum locked rotor time [s]: 50 Hz; cast iron; IE2 version (n.a. = not available)								
Nominal power [kW]	2-pole		4-pole		6-pole		8-pole	
	Cold	Hot	Cold	Hot	Cold	Hot	Cold	Hot
160	10.2	7.3	9.7	6.9	12.3	8.8	13.9	9.9
200	9.4	6.7	8.5	6.1	12.2	8.7	13.2	9.4
250	9.9	7.1	9.9	7.1	10.8	7.7	12.2	8.7
315	9.1	6.5	8.1	5.8	14.6	10.4	n.a.	n.a.

Maximum locked rotor time [s]: 60 Hz; cast iron; IE2 version (n.a. = not available)								
Nominal power [kW]	2-pole		4-pole		6-pole		8-pole	
	Cold	Hot	Cold	Hot	Cold	Hot	Cold	Hot
0.18	n.a.	n.a.	n.a.	n.a.	n.a.	n.a.	102.9	51.4
0.25	n.a.	n.a.	n.a.	n.a.	n.a.	n.a.	95.2	47.6
0.37	n.a.	n.a.	n.a.	n.a.	53.0	26.5	116.9	58.4
0.55	n.a.	n.a.	38.2	19.1	66.7	33.4	82.0	41.0
0.75	14.4	7.2	34.8	17.4	58.4	29.2	57.0	28.5
1.1	10.8	5.4	27.7	13.8	44.8	22.4	52.8	26.4
1.5	10.0	5.0	23.7	11.8	39.6	19.8	41.5	20.8
2.2	10.4	5.2	20.5	10.3	23.7	11.9	23.1	11.6
3	10.1	5.0	16.8	8.4	23.0	11.5	20.8	10.4
4	13.7	6.8	15.5	7.7	20.0	10.0	42.5	21.3
5.5	11.2	5.6	23.9	12.0	17.1	8.6	33.0	16.5
7.5	10.1	5.1	10.5	5.3	18.4	9.2	34.4	17.2
11	17.8	8.9	16.5	8.2	16.4	8.2	24.5	12.2
15	14.5	7.2	16.2	8.1	22.7	11.4	24.8	12.4
18.5	16.4	8.2	25.7	12.9	24.9	12.4	47.8	23.9
22	16.6	8.3	22.8	11.4	24.6	12.3	50.2	25.1
30	16.7	8.4	16.4	8.2	30.3	15.1	29.2	14.6
37	16.5	8.2	22.9	11.5	27.4	13.7	33.9	24.2
45	16.4	8.2	16.7	8.4	26.2	18.7	33.2	23.7
55	21.8	10.9	16.8	8.4	24.5	17.5	24.5	17.5
75	16.7	11.9	15.5	11.1	20.3	14.5	23.9	17.1
90	14.1	10.1	12.7	9.1	17.4	12.4	15.5	11.1
110	17.9	12.8	11.8	8.4	16.8	12.0	15.1	10.8
132	13.7	9.8	10.5	7.5	24.5	17.5	23.9	17.1
160	11.6	8.3	8.4	6.0	17.8	12.7	15.5	11.1
200	11.5	8.2	8.4	6.0	13.2	9.4	15.1	10.8
250	10.8	7.7	8.3	5.9	12.3	8.8	n.a.	n.a.
315	8.4	6.0	7.4	5.3	15.5	11.1	n.a.	n.a.

5.5 Motor performance (inverter operated)

5.5.1 General

When line operated, asynchronous motors provide an almost fixed rotational speed depending on line frequency and pole number. When feeding the motor by an electronic frequency inverter with variable frequency and voltage a “Variable Speed Drive System” is generated. It shows remarkable benefits for energy efficiency and enables a low-cost and maintenance-free solution for flexible control of processes. (Control system which only are varying the voltage are not covered here; they are only permissible for short-term use like soft starters).

Technical details can be seen in IEC 60034-17 (for general purpose motors) and IEC 60034-25 (for motors especially designed for inverter operation). The motors covered by this catalogue are general purpose motors; they are suitable for operation with a frequency inverter. Several items have to be observed when the motors are inverter operated (details following sections):

General:	see section ...
additional losses due to non-sinusoidal supply voltage	5.5.3
increased winding insulation stress	5.5.4
increased acoustic noise level due to non- sinusoidal supply voltage	5.5.7
additional bearing currents	5.5.5
EMC considerations	5.5.6
Depending on operational range:	
decreased cooling of self-ventilated motors at low speed	5.5.3
increased acoustic noise level of self-ventilated motors at high speed	5.5.7
shortening of regreasing intervals when permanently operated at high speed	3.4.4
max speed due to decrease of breakdown torque in the field weakening range	6 (breakdown torque)
Maximum operational speed	5.3.2

5.5.2 Operational range; principle

At inverter operation (variable frequency and voltage) the speed-torque-characteristic curve of the motor (see Figure 1-2, page 11) can be shifted along the speed axis in any position. It allows permanent operation at any speed and torque at both directions of rotation. Depending on the design of the inverter operation in the generator range is possible as well:

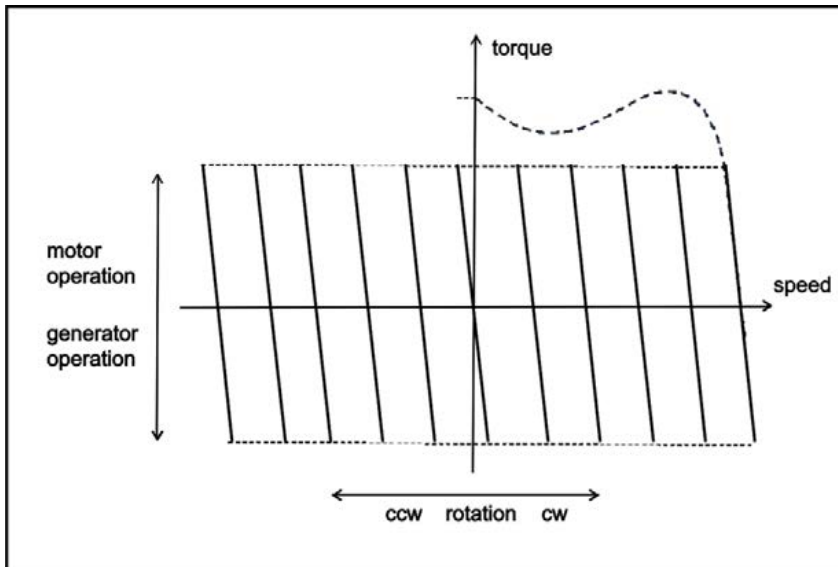

Figure 5-8: Operational range of inverter operated induction motors (range with constant flux)

In addition the frequency can also be adjusted to higher than the nominal frequency while the voltage is kept constant (field weakening operation). The operational range then is defined by two sections, see figure below:

- constant flux range: frequency and voltage are almost proportional; the achievable torque is constant
- field weakening range: frequency is increased at constant voltage: the achievable power is constant.

Remark: In the field weakening range a quadratic decrease of breakdown torque has to be regarded. Thus the max speed may be restricted depending on the motor data.

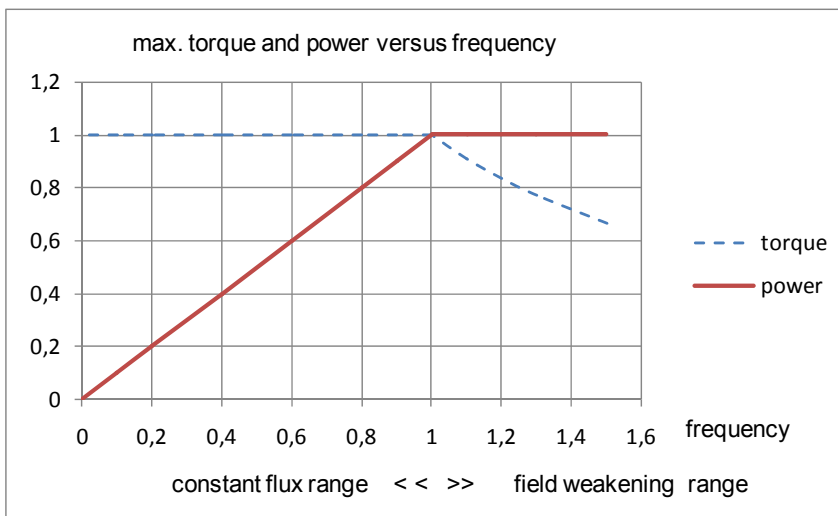

Figure 5-9: Max. torque and power versus frequency

5.5.3 Operational range for continuous operation

In general the inverter provides a non-sinusoidal supply voltage for the motor. As a consequence additional harmonic currents and additional losses are generated, especially in the rotor. The amount of additional losses is depending on the design of the inverter. In case of a PWM inverter (voltage source inverter with pulse shaped output voltage) the losses are significantly depending on the pulse frequency. As a rough figure the pulse frequency shall be 3 kHz–5 kHz at least under this aspect. Motors covered by this catalogue in general are suitable for continuous operation with nominal output under this precondition.

Configuration for 87 Hz:

If a motor is designed for 50 Hz in star connection of the winding, it can be operated up to 87 Hz in constant flux operation, if the winding connection is changed to delta connection. The theoretically achievable maximal power then is $\sqrt{3}$ of nominal at $\sqrt{3}$ of nominal speed. However, as the core losses are increased at higher frequency, the output power for continuous operation at 87 Hz is only approximately in the range of 1,5 of nominal (small motors) and 1,2 of nominal (large motors), see figure below: The exact value for a specific motor type and type of inverter can be evaluated on request. (Max. mechanical speed for the motor type has to be regarded.)

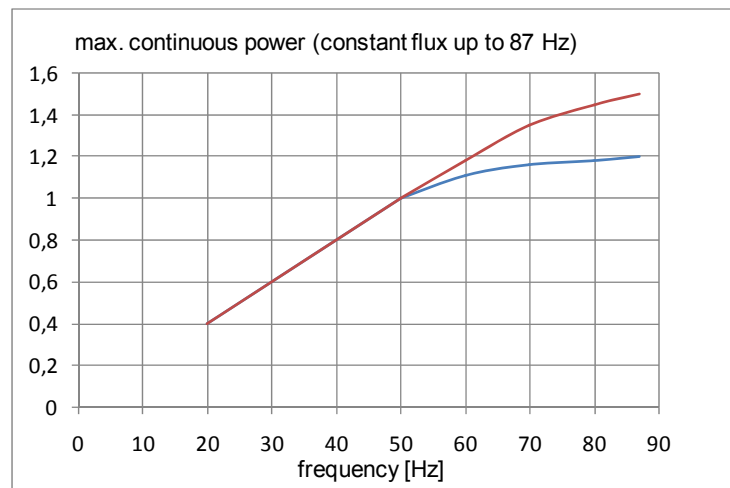

Figure 5-10: Typical characteristics for max. continuous power in “87 Hz-configuration”

Maximum permissible torque and power for continuous operation within the speed range: In 5.5.2 Operational range; principle the achievable characteristics are shown. For continuous operation it has to be regarded that the losses of the motor and (in case of self ventilated design) the heat transfer is depending on the operation point. As a consequence the typical characteristics for maximum permissible torque versus speed (and power versus speed) is given; see figures below. (speed 0...1 = operation with nominal flux; speed > 1 = field weakening operation). The exact value for a concrete motor type and type of inverter can be evaluated on request.

Remark: In the field weakening range a quadratic decrease of breakdown torque has to be regarded. Thus the max speed may be restricted depending on the motor data.

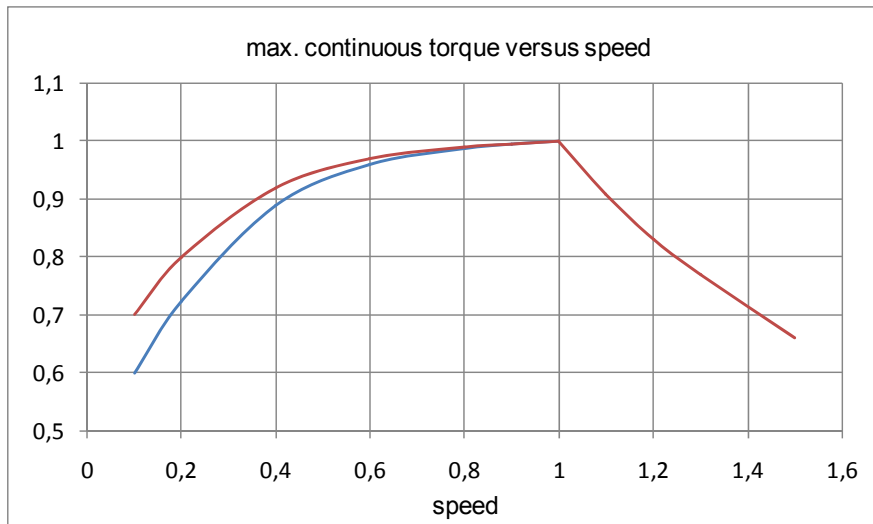

Figure 5-11: Typical max. continuous torque (self ventilated motors)

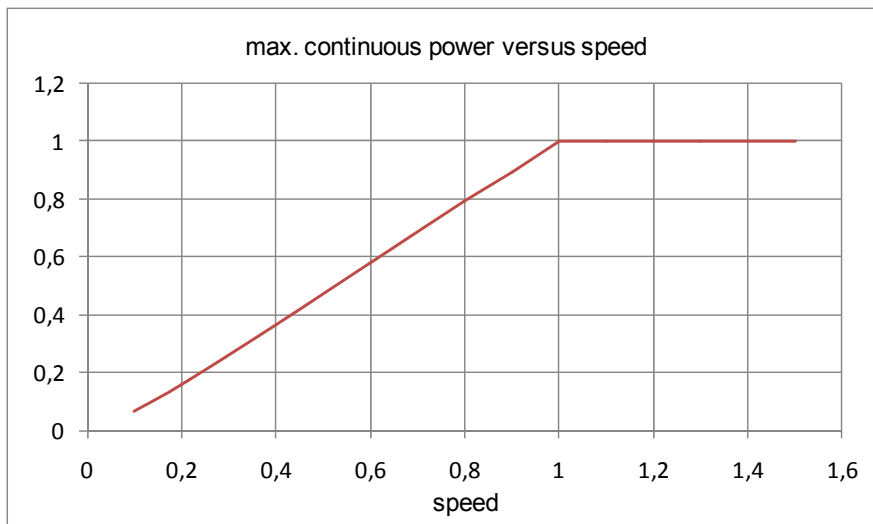

Figure 5-12: Typical max. continuous power (self ventilated motors)

For drive application with quadratic torque characteristic this restriction is not relevant. Drives with constant torque demand either a motor with accordingly higher rating or the use of forced ventilation. If forced ventilation is used (cooling method "IC 416" according to IEC 60034-6) the cooling is independent from the motor speed. Continuous operation is permissible according to figure below:

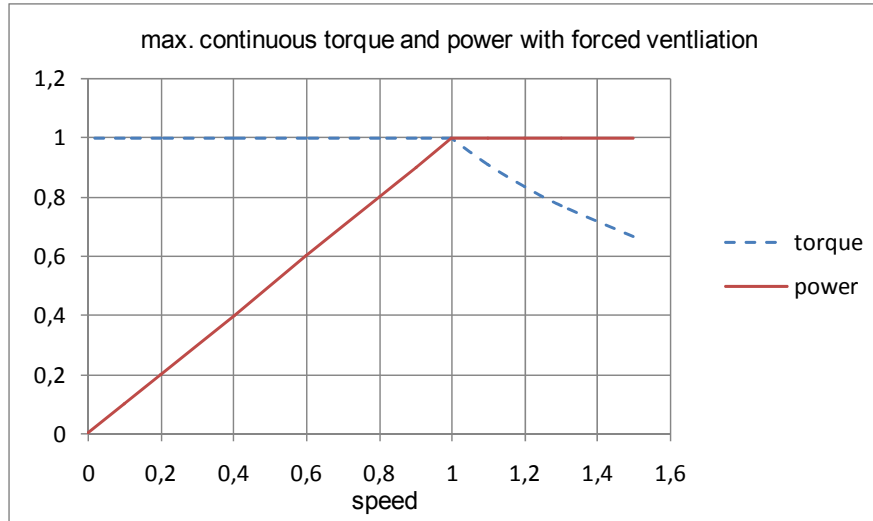

Figure 5-13: Max. continuous torque and power (motors with forced ventilation)

5.5.4 Winding insulation stress

In case of using PWM inverters a pulse shaped voltage is applied to the motor winding. The height of the voltage pulses is depending on the DC link voltage. In addition the voltage pulses show a voltage overshoot. Waveform and peak voltage are a function of both motor cable length and inverter specific pulse shape.

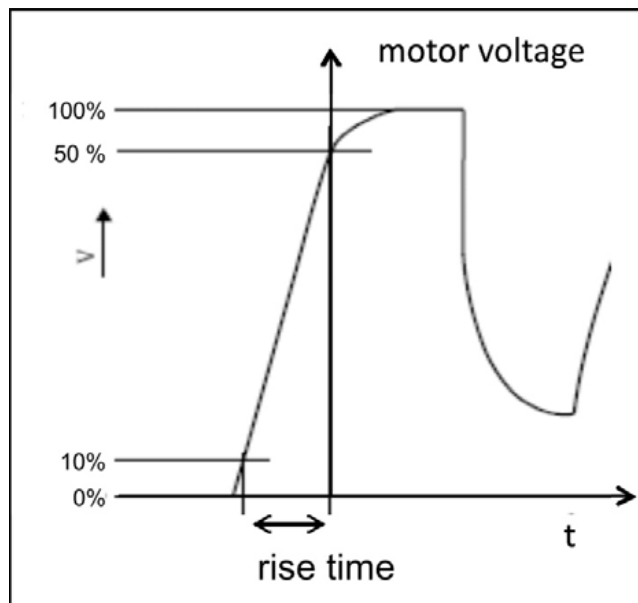

Figure 5-14: Typical pulse waveform and definition of rise time according to IEC 60034-17

Short rise time of the voltage pulses effects an unbalanced voltage contribution within the winding and therefore increases the dielectric stress. The winding stress is defined as a combination of both peak voltage and voltage rise time. A characteristic describes limits for admissible peak voltage versus voltage versus rise time. In IEC Technical Specification "TS 60034-17" (Cage induction motors when fed from converters- Application guide; edition 2006-05) a limit curve is defined for general purpose motors. Motors covered by this catalogue comply with the curve in this standard, shown in the diagram below:

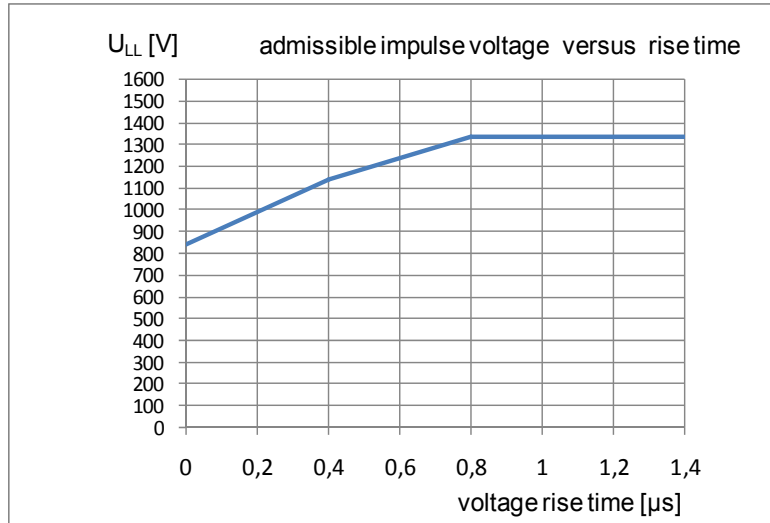

Figure 5-15: Admissible peak voltage versus rise time according to IEC TS 60034-17 (2006)

At high nominal voltage level (e.g. 690 V) and especially in case of long motor cables these requirements can only be fulfilled by using “dV/dt filters” which are increasing the voltage rise time and decrease the amount of voltage overshoot. In some cases even expensive “sine wave filters” may be required.

5.5.5 Inverter caused bearing currents

PWM inverters in general are generating a high frequency “common mode voltage”. There are several mechanisms which can produce harmful high frequency current through the bearings. A listing of possible counter measures can be seen below:

Counter measure	Remarks
Insulation of NDE bearing	Recommended by TECO for frame size 280 and higher
Inverter filters (dV/dt filter; common mode filter)	
Choice of a low inverter switching frequency	
Use of non-conductive coupling	
Symmetric power cabling and effective motor grounding	

As a simplified rule to avoid problems both with bearing current and winding insulation TECO recommends general precautions according table below (voltage limits according to the insulation system chosen has to be regarded):

TECO general recommendations		
Rated voltage	Frame size < 250	Frame size ≥ 280
≤ 460 V	Standard motor (Motor cable lengths < 20 m)	Standard motor + Insulated NDE bearing
≤ 600V	Standard motor + dV/dt-filter (reactor) or Reinforced insulation	Standard motor + dV/dt-filter (reactor) + Insulated NDE bearing or Reinforced insulation + Insulated NDE bearing
≤ 690V	Reinforced insulation + dV/dt-filter (reactor)	Reinforced insulation + dV/dt-filter (reactor) + Insulated NDE bearing

Table 5-6: TECO recommendations for general precautions at inverter operation

5.5.6 Electromagnetic compatibility

If squirrel cage motors are line operated, the electromagnetic emissions are regarded as negligible (see IEC 60034-1, section 13). The motors meet the limit values of Class B of EN 55011 and therefore can be used both in industrial and residential environment.

If inverter operated the EMC performance can only be considered for the complete drive system (inverter, filters, cabling, motor) as an entity, according to the relevant product standard EN 61800-3 (“Adjustable speed electrical power drive systems; EMC requirements and specific test methods...”).

For this purpose TECO motors e.g. are equipped with a metallic terminal box with cable entries suitable for the use of EMC-compliant cable glands.

5.5.7 Additional acoustic noise

Due to the non-sinusoidal motor voltage the acoustic noise level in general is increased at inverter operation. The increase is depending on the type and technical data of the inverter (at PWM inverters especially the pulse frequency and the pulse generation method) and cannot be stated generally.

Increase at nominal speed:

As a rule of thumb an increase at nominal speed can be expected when fed from inverter:

- approx. 1–3 dB(A) in case of a current source inverter or a PWM inverter with high pulse frequency
- approx. 1–10 dB(A) in case of a customary PWM inverter.

If acoustic noise is a relevant feature in the application, the cast iron version shall be preferred instead of aluminium design.

Speeds higher than nominal speed:

Self ventilated motors are generating an increased fan noise at higher speed. A rough estimation for the increase of overall sound level is shown in the table below (the increase can be minimized by using the option “Forced ventilation”).

	Increase of sound pressure level [dB(A)]			
	50 Hz	60 Hz	75 Hz	100 Hz
2-pole motor	0	4	10	16
4-pole motor	0	3	7	12
6 and 8 pole motor	0	3	6	8

Table 5-7: Acoustic sound increase to be expected at high speed (self ventilated motors)

6 Technical data

6.1 General data; tolerances (acc. to IEC 60034-1)

Rating, Performance	
Product Group, Design standard	Low Voltage Squirrel Cage Induction Motor, IEC 60034
Nominal voltages	3 AC; 230 V–690 V; tolerance see Figure 5-7, page 48
Winding configuration	Star/Delta, 6 winding ends
Winding temperature rise	Less than 80 K acc. Utilization B (by resistance method)
Method of starting	Full Voltage Direct On Line or Star/Delta starting
Nominal frequency	50 Hz or 60 Hz; tolerance according to IEC 60034-1
Inverter Operation	Suitable for inverter operation according to IEC 60034-17
Output range	0,12 kW–315 kW
Duty type	Continuous (S1); SF 1.0 (data for other duty types on request)
Efficiency	IE2 or IE3 according to IEC 60034-30
Range of frame size	From 63 up to 315
Pole numbers	2-pole; 4-pole; 6-pole and 8-pole
Rotational speed (synchronous)	750 rpm–3000 rpm (50 Hz); 900 rpm–3600 rpm (60 Hz)
Operational speed limit	See 5.3.2 Maximum operational speed, starting page 43
Rotational direction	Clockwise acc. IEC definition; suitable for bidirectional operation
Locked rotor torque	Tolerance: –15 %; +25 %
Pull up torque	Tolerance: –15 % (Minimum: 30 % of FLT)
Breakdown torque	>160 % of full load torque; tolerance – 10 % included
Slip	Tolerance: ±30 % for rating < 1 kW; ±20 % for rating ≥ 1 kW
Efficiency η	Tolerance: –0,15 (1– η) for rating < 150 kW; –0,1 (1– η) for rating ≥ 150 kW
Power factor $\cos \varphi$	Tolerance: (1– $\cos \varphi$)/6 (min. 0,02; max 0,07)
Locked rotor current	Tolerance: +20 %
Acoustic noise level	Tolerance +3dB(A) acc. to IEC 60034-1
Vibration Level	Level A according to IEC 60034-14

Application, Construction	
Site condition	Shadow, Non-hazardous
Ambient Temperature	-20 °C to +40 °C
Site Altitude	Less than 1000 m
Relative Humidity	Less than 90 % RH (Non-Condensation)
Enclosure	Totally Enclosed (IP55 acc. to IEC)
Cooling Method	Self Ventilated, Surface Cooled, "TEFC" (IC 411 acc. to IEC code)
Mounting	Foot Mounting (B3), Flange Mounting (B5 and B14) and derivatives
Stator Winding	Random Wound, Copper wire, Thermal class F insulation
Rotor Winding	Squirrel cage, Aluminium Conductor
Power Connectors	See section 3.2 Terminal box and cable entry, starting page 21
Bearings, Lubrication	See section 3.4 Rotor assembly (active part, shaft, bearings), starting page 27
Material (housing, end shields)	Die-Casting Aluminium ("ALAA...") or Cast Iron ("ALCA...")
Painting	Pebble Grey (RAL 7032)

General tolerances of dimensions (nomenclature acc. dimensional diagram)		
Motor mass	m	-5 %...+10 %
Rotor inertia	J	±10 %
Radial spacing of feet fixing holes	A	±1 mm
Axial spacing of feet fixing holes	B	±1 mm
Shaft height	H	frame ≤ 250: -0,5 mm; frame > 250: -1mm
Pitch circle diameter of flange	M	±0,8 mm
Shaft end diameter	D	see dimensional diagram

6.2 Type data for aluminium version

Remarks (valid for all following tables with performance data):

1. The typical values above are based on test according to IEC 60034, especially IEC 60034-2-1.
2. All tolerances are according to IEC 60034-1.
3. Design and operation at other nominal voltages: The full load current has to be calculated inversely with the voltage; all other data are the same.
4. Rating 0.55 kW and below and 8-pole motors an D* marked values: Efficiency per TECO performance standard.

6.2.1 Aluminium; 400 V; 50 Hz; Class IE2

2-pole

Power rating	Nominal speed	Frame size Type code ALAA...	Nominal current	Locked rotor current (multiple of nominal current)	Efficiency at load points				Power factor at load points				Nominal torque	Locked rotor torque (multiple of nominal torque)	Pull up torque (multiple of nominal torque)	Break down torque (multiple of nominal torque)	Moment of Inertia	Total mass (B3 version; approx.)	Sound pressure; Noise level																			
																				P_N	n_n	I_N	I_L/I_N	η				$\cos \varphi$				T_N	T_L/T_N	T_P/T_N	T_B/T_N	J	m	dB(A)
																				[kW]	[rpm]	[A]		[%]								[Nm]					kgm ²	[kg]
					Full load	3/4 load	2/4 load	1/4 load	Full load	3/4 load	2/4 load	1/4 load																										
0,18	2775	0063M0	0,49	4,41	67,4	67,4	60,4	48,0	0,79	0,69	0,55	0,38	0,62	1,90	1,70	2,00	$0,17 \times 10^{-3}$	5,0	53																			
0,25	2785	0063M1	0,65	4,50	69,9	70,0	65,7	49,0	0,79	0,70	0,56	0,39	0,86	1,95	1,70	2,05	$0,21 \times 10^{-3}$	6,0	53																			
0,37	2790	0071M0	0,93	4,86	71,0	71,0	66,7	52,5	0,81	0,71	0,55	0,36	1,27	1,90	1,70	2,20	$0,17 \times 10^{-3}$	8,0	55																			
0,55	2780	0071M1	1,27	5,32	75,5	76,2	73,3	59,0	0,83	0,75	0,59	0,39	1,89	1,90	1,70	2,20	$0,33 \times 10^{-3}$	9,0	56																			
0,75	2815	0080M0	1,63	5,85	77,4	78,6	77,4	66,2	0,86	0,79	0,67	0,44	2,54	3,10	2,70	3,00	$0,46 \times 10^{-3}$	12,0	57																			
1,1	2820	0080M1	2,32	6,90	79,6	80,8	80,0	73,1	0,86	0,80	0,68	0,46	3,72	3,35	2,95	3,25	$0,75 \times 10^{-3}$	14,0	57																			
1,5	2865	0090S0	3,11	7,71	81,3	82,0	80,9	73,9	0,86	0,80	0,69	0,46	5,00	3,10	2,90	3,30	$1,0 \times 10^{-3}$	17,0	56																			
2,2	2860	0090L0	4,39	7,45	83,2	84,0	83,2	77,1	0,87	0,82	0,72	0,51	7,34	3,05	2,75	3,20	$1,5 \times 10^{-3}$	20,0	57																			
3	2880	0100L0	6,06	7,45	84,6	85,5	84,8	78,3	0,85	0,79	0,66	0,45	9,94	3,05	2,55	3,35	$4,0 \times 10^{-3}$	27,0	59																			
4	2905	0112M0	7,78	7,75	85,8	86,3	85,3	78,9	0,87	0,83	0,75	0,55	13,1	1,95	1,80	2,85	$8,25 \times 10^{-3}$	35,0	64																			
5,5	2930	0132S0	11,3	7,05	87,0	87,0	85,6	79,4	0,81	0,75	0,64	0,42	17,9	2,65	2,45	3,05	$13,5 \times 10^{-3}$	51,0	69																			
7,5	2920	0132S1	15,7	7,00	88,1	88,4	87,5	80,9	0,79	0,73	0,62	0,41	24,5	2,80	2,50	3,00	16×10^{-3}	56,0	69																			
11	2950	0160M0	19,9	8,28	89,5	90,5	90,0	85,5	0,89	0,86	0,77	0,57	35,6	2,30	1,80	3,05	38×10^{-3}	87,0	74																			
15	2950	0160M1	26,6	8,46	90,5	91,5	91,0	87,5	0,90	0,86	0,78	0,58	48,5	2,45	1,95	3,15	48×10^{-3}	98,0	74																			
18,5	2945	0160L0	32,2	9,00	91,0	92,0	92,0	88,5	0,91	0,91	0,86	0,71	60,0	2,60	1,85	3,10	59×10^{-3}	109	73																			

4-pole

Power rating	Nominal speed	Frame size Type code ALAA...	Nominal current	Locked rotor current (multiple of nominal current)	Efficiency at load points				Power factor at load points				Nominal torque	Locked rotor torque (multiple of nominal torque)	Pull up torque (multiple of nominal torque)	Break down torque (multiple of nominal torque)	Moment of inertia	Total mass (B3 version; approx.)	Sound pressure; Noise level																				
																				P_N	n_n	I_N	I_l/I_N	η				$\cos \phi$				T_N	T_l/T_N	T_p/T_N	T_b/T_N	J	m	dB (A)	
																				[kW]	[rpm]	[A]		[%]								[Nm]					kgm ²	[kg]	
																								Full load	3/4 load	2/4 load	1/4 load	Full load	3/4 load	2/4 load	1/4 load								
0,18	1375	0063M1	0,54	3,90	65,0	63,8	58,2	43,6	0,75	0,64	0,50	0,35	1,25	2,00	1,80	2,00	$0,43 \times 10^{-3}$	6,0	42																				
0,25	1380	0071M0	0,67	4,20	69,5	70,1	66,2	51,8	0,77	0,67	0,52	0,35	1,73	2,00	1,75	2,00	$0,67 \times 10^{-3}$	8,0	46																				
0,37	1385	0071M1	1,02	4,20	69,5	69,9	66,3	52,2	0,75	0,65	0,50	0,33	2,55	2,05	1,80	2,05	$0,8 \times 10^{-3}$	9,0	46																				
0,55	1435	0080M0	1,34	6,60	78,1	78,1	75,2	63,6	0,76	0,69	0,56	0,37	3,66	2,55	2,20	2,80	$2,6 \times 10^{-3}$	13,0	48																				
0,75	1430	0080M1	1,75	6,15	79,6	79,6	76,1	67,1	0,78	0,71	0,59	0,38	5,01	2,45	2,15	2,70	$3,0 \times 10^{-3}$	14,0	52																				
1,1	1435	0090S0	2,44	6,95	81,4	81,4	79,2	71,4	0,80	0,72	0,58	0,37	7,32	2,65	2,30	3,05	$3,5 \times 10^{-3}$	15,0	50																				
1,5	1430	0090L0	3,27	7,05	82,8	83,2	81,9	74,6	0,80	0,72	0,59	0,40	10,0	2,75	2,35	3,15	$4,5 \times 10^{-3}$	19,0	50																				
2,2	1435	0100L0	4,62	6,95	84,3	86,3	86,5	81,0	0,82	0,77	0,64	0,43	14,6	2,80	2,55	2,85	$9,8 \times 10^{-3}$	26,0	53																				
3	1430	0100L1	6,45	6,50	85,5	86,5	86,7	80,8	0,79	0,73	0,60	0,42	20,0	2,70	2,50	2,75	11×10^{-3}	28,0	53																				
4	1440	0112M0	7,98	7,85	86,6	87,0	87,0	81,4	0,84	0,79	0,68	0,47	26,5	2,85	2,30	2,85	$16,3 \times 10^{-3}$	35,0	58																				
5,5	1450	0132S0	10,8	7,40	87,7	88,2	86,9	81,0	0,84	0,79	0,67	0,46	36,2	2,55	2,15	2,95	36×10^{-3}	55,0	60																				
7,5	1455	0132M0	14,5	7,50	88,7	88,8	88,0	83,1	0,84	0,79	0,68	0,47	49,2	2,65	2,15	3,00	44×10^{-3}	59,0	61																				
11	1465	0160M0	20,5	7,80	90,0	90,5	90,0	86,0	0,86	0,82	0,73	0,52	71,7	2,00	1,50	2,40	74×10^{-3}	80,0	65																				
15	1465	0160L0	27,5	8,00	91,0	91,5	91,0	88,0	0,87	0,83	0,74	0,54	97,7	2,20	1,55	2,55	107×10^{-3}	108	65																				

6-pole

Power rating	Nominal speed	Frame size Type code ALAA...	Nominal current	Locked rotor current (multiple of nominal current)	Efficiency at load points				Power factor at load points				Nominal torque	Locked rotor torque (multiple of nominal torque)	Pull up torque (multiple of nominal torque)	Break down torque (multiple of nominal torque)	Moment of inertia	Total mass (B3 version; approx.)	Sound pressure; Noise level																				
																				P_N	n_n	I_N	I_l/I_N	η				$\cos \varphi$				T_N	T_l/T_N	T_p/T_N	T_b/T_N	J	m	dB (A)	
																				[kW]	[rpm]	[A]		[%]								[Nm]					kgm ²	[kg]	
																								Full load	3/4 load	2/4 load	1/4 load	Full load	3/4 load	2/4 load	1/4 load								
0,18	935	0071M0	0,63	3,70	62,5	60,0	52,4	38,5	0,66	0,56	0,45	0,32	1,84	1,80	1,65	2,05	$1,41 \times 10^{-3}$	9,0	43																				
0,25	935	0071M1	0,85	3,70	65,0	63,0	55,5	38,5	0,67	0,56	0,44	0,31	2,55	2,00	1,80	2,20	$1,67 \times 10^{-3}$	10,0	44																				
0,37	920	0080M0	1,24	3,65	65,5	64,5	59,0	42,3	0,66	0,57	0,46	0,30	3,84	1,75	1,55	2,00	$1,64 \times 10^{-3}$	12,0	46																				
0,55	920	0080M1	1,64	5,70	74,0	74,6	72,2	61,1	0,66	0,57	0,46	0,30	5,71	1,85	1,65	2,10	$3,15 \times 10^{-3}$	13,0	46																				
0,75	935	0090S0	2,08	5,05	75,9	76,4	74,3	62,5	0,69	0,60	0,47	0,30	7,66	2,25	2,25	2,40	$4,25 \times 10^{-3}$	20,0	50																				
1,1	935	0090L0	3,03	5,25	78,1	78,6	76,4	64,8	0,67	0,59	0,46	0,29	11,2	2,30	2,25	2,50	$5,75 \times 10^{-3}$	22,0	50																				
1,5	945	0100L0	3,64	5,85	79,8	81,4	80,9	71,0	0,75	0,68	0,55	0,37	15,2	2,20	1,90	2,25	$11,5 \times 10^{-3}$	33,0	52																				
2,2	955	0112M0	5,21	5,90	81,8	81,9	79,8	70,8	0,75	0,68	0,56	0,36	22,0	2,00	1,85	2,60	22×10^{-3}	38,0	53																				
3	965	0132S0	6,42	6,90	83,3	83,4	81,6	73,6	0,81	0,75	0,62	0,41	29,7	2,35	2,05	3,00	43×10^{-3}	49,0	55																				
4	965	0132M0	8,48	7,15	84,6	84,7	83,2	75,6	0,81	0,74	0,62	0,41	39,6	2,35	2,05	3,00	54×10^{-3}	56,0	57																				
5,5	970	0132M1	11,5	7,30	86,0	86,1	84,5	77,8	0,81	0,74	0,61	0,40	54,1	2,30	2,05	3,00	68×10^{-3}	68,0	57																				
7,5	960	0160M0	15,9	6,60	88,0	89,5	89,5	85,0	0,78	0,71	0,59	0,38	74,6	2,45	1,95	2,50	91×10^{-3}	100	60																				
11	965	0160L0	22,9	7,42	90,0	91,0	90,5	87,5	0,77	0,71	0,59	0,39	109	2,70	2,05	2,70	140×10^{-3}	121	60																				

8-pole

Power rating	Nominal speed	Frame size Type code ALAA...	Nominal current	Locked rotor current (multiple of nominal current)	Efficiency at load points				Power factor at load points				Nominal torque	Locked rotor torque (multiple of nominal torque)	Pull up torque (multiple of nominal torque)	Break down torque (multiple of nominal torque)	Moment of inertia	Total mass (B3 version; approx.)	Sound pressure; Noise level	
					η	$\cos \phi$														
P_N	n_n		I_N	I_L/I_N	η				$\cos \phi$				T_N	T_L/T_N	T_P/T_N	T_B/T_N	J	m	dB(A)	
[kW]	[rpm]		[A]		[%]								[Nm]				kgm ²	[kg]		
					Full load	3/4 load	2/4 load	1/4 load	Full load	3/4 load	2/4 load	1/4 load								
0,18	690	0080M0	0,86	3,95	55,0	51,5	43,5	29,5	0,55	0,47	0,39	0,28	0,28	1,65	4,55	2,00	$1,9 \times 10^{-3}$	13,0		
0,25	690	0080M1	1,13	3,00	58,0	54,5	47,0	29,5	0,55	0,47	0,39	0,28	3,46	1,65	1,55	2,00	$2,5 \times 10^{-3}$	14,0		
0,37	695	0090S0	1,38	3,50	62,0	59,5	53,0	35,0	0,63	0,55	0,44	0,31	5,08	1,65	1,55	2,00	$4,1 \times 10^{-3}$	20,0		
0,55	690	0090L0	2,07	3,50	63,0	60,5	54,0	36,5	0,61	0,53	0,43	0,30	7,61	1,70	1,60	2,05	$4,9 \times 10^{-3}$	22,0		
0,75	695	0100L0	2,32	3,90	71,8	73,0	69,5	56,0	0,65	0,56	0,45	0,29	10,3	1,90	1,70	2,00	$8,5 \times 10^{-3}$	27,0		
1,1	695	0100L1	3,22	4,10	74,7	76,0	73,5	6,10	0,66	0,58	0,46	0,29	15,1	1,90	1,70	2,00	$12,3 \times 10^{-3}$	33,0		
1,5	700	0112M0	4,24	4,25	76,8	77,5	75,0	62,0	0,67	0,57	0,44	0,27	20,5	1,85	1,80	2,20	$14,6 \times 10^{-3}$	38,0		
2,2	715	0132S0	5,55	5,15	79,4	80,0	79,5	70,0	0,72	0,63	0,50	0,31	29,4	1,75	1,45	2,25	34×10^{-3}	53,0		
3	715	0132M0	7,40	5,15	81,3	82,0	81,0	73,0	0,72	0,64	0,50	0,31	40,0	1,75	1,45	2,30	45×10^{-3}	64,0		
4	715	0160M0	9,73	5,65	83,0	84,0	82,0	73,5	0,72	0,63	0,51	0,31	53,4	1,70	1,60	2,45	86×10^{-3}	90,0		
5,5	715	0160M1	13,2	5,30	84,5	84,0	82,5	74,0	0,71	0,63	0,51	0,31	73,4	1,65	1,60	2,40	86×10^{-3}	107		
7,5	720	0160L0	18,0	5,85	86,0	86,0	84,0	76,0	0,70	0,61	0,49	0,30	99,4	1,90	1,80	2,70	147×10^{-3}	122		

6.2.2 Aluminium; 460 V; 60 Hz; Class IE2

2-pole

Power rating	Nominal speed	Frame size Type code ALAA...	Nominal current	Locked rotor current (multiple of nominal current)	Efficiency at load points				Power factor at load points				Nominal torque	Locked rotor torque (multiple of nominal torque)	Pull up torque (multiple of nominal torque)	Break down torque (multiple of nominal torque)	Moment of Inertia	Total mass (B3 version; approx.)	Sound pressure; Noise level																			
																				P_N	n_n	I_N	I_L/I_N	η				$\cos \varphi$				T_N	T_L/T_N	T_P/T_N	T_B/T_N	J	m	dB (A)
																				[kW]	[rpm]	[A]		[%]								[Nm]				kgm ²	[kg]	
																								Full load	3/4 load	2/4 load	1/4 load	Full load	3/4 load	2/4 load	1/4 load							
0,18	3390	0063M0	0,45	5,40	69,0	67,3	61,3	49,2	0,73	0,64	0,51	0,36	0,51	2,40	2,00	2,40	$0,25 \times 10^{-3}$	5,0	57																			
0,25	3400	0063M1	0,59	5,35	70,0	69,0	63,8	49,2	0,76	0,67	0,54	0,37	0,70	2,35	1,95	2,35	$0,25 \times 10^{-3}$	6,0	57																			
0,37	3440	0071M0	0,82	5,90	75,0	73,7	68,7	55,2	0,76	0,65	0,51	0,34	1,03	2,25	2,20	3,40	$0,25 \times 10^{-3}$	8,0	59																			
0,55	3440	0071M1	1,05	6,60	79,0	78,8	75,4	63,6	0,84	0,74	0,60	0,39	1,53	2,20	2,15	3,35	$0,5 \times 10^{-3}$	9,0	60																			
0,75	3465	0080M0	1,42	8,45	80,7	80,3	77,5	68,0	0,82	0,75	0,63	0,43	2,07	3,30	3,10	3,55	$0,75 \times 10^{-3}$	12,0	61																			
1,1	3465	0080M1	1,99	9,05	82,5	82,5	80,4	72,0	0,84	0,78	0,66	0,45	3,03	3,50	3,30	3,75	$1,0 \times 10^{-3}$	14,0	61																			
1,5	3490	0090S0	2,67	9,40	84,0	83,8	81,6	73,0	0,84	0,78	0,67	0,46	4,10	3,10	2,95	3,40	$1,5 \times 10^{-3}$	17,0	60																			
2,2	3480	0090L0	3,69	9,50	85,5	85,5	84,2	78,0	0,88	0,83	0,74	0,52	6,03	3,00	2,85	3,30	$2,0 \times 10^{-3}$	20,0	61																			
3	3495	0100L0	5,12	9,45	87,5	87,5	86,0	79,0	0,84	0,78	0,67	0,45	8,19	2,90	2,50	3,30	$4,0 \times 10^{-3}$	27,0	63																			
4	3515	0112M0	6,63	9,40	87,5	87,5	85,8	79,0	0,87	0,83	0,74	0,55	10,9	2,45	2,10	3,45	$8,25 \times 10^{-3}$	35,0	68																			
5,5	3535	0132S0	10,2	7,75	88,5	88,0	85,5	77,0	0,77	0,71	0,60	0,40	14,9	3,00	2,45	3,10	$13,5 \times 10^{-3}$	51,0	73																			
7,5	3550	0132S1	13,8	7,95	89,5	89,2	87,5	79,3	0,76	0,70	0,60	0,36	20,3	3,00	2,45	3,10	16×10^{-3}	56,0	73																			
11	3550	0160M0	17,2	9,60	90,2	90,5	89,0	82,0	0,89	0,86	0,78	0,60	29,6	2,95	2,20	3,65	38×10^{-3}	87,0	78																			
15	3555	0160M1	23,3	9,65	90,2	90,5	89,5	84,0	0,90	0,87	0,79	0,60	40,3	3,10	2,20	3,5	48×10^{-3}	98,0	78																			
18,5	3545	0160L0	27,8	9,70	91,7	92,0	91,5	87,5	0,91	0,90	0,86	0,71	49,8	2,75	1,85	3,05	59×10^{-3}	109	77																			

4-pole

Power rating	Nominal speed	Frame size Type code ALAA...	Nominal current	Locked rotor current (multiple of nominal current)	Efficiency at load points				Power factor at load points				Nominal torque	Locked rotor torque (multiple of nominal torque)	Pull up torque (multiple of nominal torque)	Break down torque (multiple of nominal torque)	Moment of inertia	Total mass (B3 version; approx.)	Sound pressure; Noise level	
					η	$\cos \phi$			$\cos \phi$											
P_N	n_n		I_N	I_l/I_N	η				$\cos \phi$				T_N	T_l/T_N	T_p/T_N	T_b/T_N	J	m	dB (A)	
[kW]	[rpm]		[A]		[%]								[Nm]				kgm ²	[kg]		
					Full load	3/4 load	2/4 load	1/4 load	Full load	3/4 load	2/4 load	1/4 load								
0,18	1700	0063M1	0,49	4,50	69,0	66,3	60,2	45,7	0,67	0,56	0,44	0,30	1,01	2,3	2,2	2,55	$0,50 \times 10^{-3}$	6,0	46	
0,25	1705	0071M0	0,62	4,90	72,5	71,2	66,5	52,6	0,70	0,60	0,47	0,31	1,40	2,15	2,05	2,50	$0,75 \times 10^{-3}$	8,0	50	
0,37	1705	0071M1	0,92	4,95	74,0	72,8	68,4s	54,7	0,69	0,59	0,46	0,30	2,07	2,20	2,15	2,60	$0,75 \times 10^{-3}$	9,0	50	
0,55	1745	0080M0	1,18	7,60	81,2	80,2	76,8	65,6	0,72	0,64	0,52	0,34	3,01	3,1	2,85	3,4	$2,5 \times 10^{-3}$	13,0	52	
0,75	1745	0080M1	1,55	7,15	82,5	81,7	78,6	67,8	0,74	0,66	0,54	0,35	4,10	2,95	2,70	3,25	$3,0 \times 10^{-3}$	14,0	56	
1,1	1745	0090S0	2,11	8,55	84,0	83,8	81,7	73,0	0,78	0,70	0,56	0,35	6,02	3,30	2,70	3,85	$3,5 \times 10^{-3}$	15,0	54	
1,5	1745	0090L0	2,80	8,55	84,0	84,0	82,2	75,0	0,80	0,72	0,59	0,37	8,20	3,30	2,70	3,85	$4,5 \times 10^{-3}$	19,0	54	
2,2	1745	0100L0	3,92	8,95	87,5	88,0	87,0	80,6	0,81	0,75	0,64	0,41	12,0	3,15	2,65	3,20	$9,75 \times 10^{-3}$	26,0	57	
3	1740	0100L1	5,45	8,10	87,5	88,2	87,3	81,2	0,79	0,74	0,63	0,40	16,5	3,10	2,60	3,15	$11,0 \times 10^{-3}$	28,0	57	
4	1750	0112M0	7,04	9,20	87,5	88,2	87,3	82,0	0,82	0,76	0,64	0,43	21,8	3,20	2,70	3,40	$16,3 \times 10^{-3}$	35,0	62	
5,5	1760	0132S0	9,35	8,60	89,5	89,3	87,5	80,5	0,83	0,77	0,65	0,43	29,8	2,90	2,40	3,40	$36,3 \times 10^{-3}$	55,0	64	
7,5	1760	0132M0	12,8	8,50	89,5	89,5	87,8	81,7	0,83	0,77	0,66	0,44	40,7	3,00	2,50	3,60	44×10^{-3}	59,0	65	
11	1770	0160M0	17,9	8,95	91,0	91,0	90,5	86,0	0,85	0,81	0,71	0,49	59,3	2,25	1,60	2,75	74×10^{-3}	80,0	69	
15	1770	0160L0	24,1	9,35	91,5	92,0	92,0	88,0	0,86	0,81	0,71	0,49	80,9	2,50	1,75	2,95	107×10^{-3}	108	69	

6-pole

Power rating	Nominal speed	Frame size Type code ALAA...	Nominal current	Locked rotor current (multiple of nominal current)	Efficiency at load points				Power factor at load points				Nominal torque	Locked rotor torque (multiple of nominal torque)	Pull up torque (multiple of nominal torque)	Break down torque (multiple of nominal torque)	Moment of inertia	Total mass (B3 version; approx.)	Sound pressure; Noise level																				
																				P_N	n_n	I_N	I_l/I_N	η				$\cos \varphi$				T_N	T_l/T_N	T_p/T_N	T_b/T_N	J	m	dB (A)	
																				[kW]	[rpm]	[A]		[%]								[Nm]					kgm ²	[kg]	
																								Full load	3/4 load	2/4 load	1/4 load	Full load	3/4 load	2/4 load	1/4 load								
0,18	1145	0071M0	0,60	4,05	63,5	59,9	54,1	40,5	0,60	0,50	0,40	0,28	1,50	2,20	2,10	2,65	$1,5 \times 10^{-3}$	9,0	47																				
0,25	1145	0071M1	0,80	4,05	65,0	61,4	56,1	40,4	0,60	0,50	0,40	0,28	2,08	2,30	2,20	2,72	$1,75 \times 10^{-3}$	10,0	48																				
0,37	1135	0080M0	1,22	3,95	67,5	65,0	58,6	42,0	0,57	0,48	0,39	0,27	3,11	2,20	2,10	2,45	$1,75 \times 10^{-3}$	12,0	50																				
0,55	1135	0080M1	1,44	4,75	78,7	78,5	75,3	63,6	0,61	0,53	0,41	0,26	4,63	2,10	2,00	2,35	$3,25 \times 10^{-3}$	13,0	50																				
0,75	1145	0090S0	1,77	5,50	80,0	79,7	76,5	64,6	0,67	0,58	0,45	0,28	6,25	2,40	2,40	2,90	$4,25 \times 10^{-3}$	20,0	54																				
1,1	1145	0090L0	2,66	5,55	82,5 (*)	82,5	80,2	71,0	0,63	0,54	0,42	0,26	9,17	2,55	2,55	3,00	$5,75 \times 10^{-3}$	22,0	54																				
1,5	1155	0100L0	3,24	6,20	82,5 (*)	83,0	81,5	72,0	0,71	0,63	0,51	0,32	12,4	2,65	2,25	2,65	$11,5 \times 10^{-3}$	33,0	56																				
2,2	1160	0112M0	4,42	7,70	85,5 (*)	84,8	81,8	71,6	0,73	0,65	0,52	0,33	18,1	2,45	2,10	3,30	$21,5 \times 10^{-3}$	38,0	57																				
3	1175	0132S0	5,63	8,6	87,5	87,0	84,5	75,8	0,77	0,69	0,56	0,36	24,4	2,50	2,20	3,20	43×10^{-3}	49,0	59																				
4	1175	0132M0	7,45	8,75	87,5	87,0	84,7	76,7	0,77	0,70	0,57	0,37	32,5	2,50	2,20	3,20	$53,5 \times 10^{-3}$	56,0	61																				
5,5	1175	0132M1	10,0	8,95	89,5	89,0	86,8	79,0	0,77	0,70	0,57	0,36	44,7	2,50	2,20	3,20	68×10^{-3}	68,0	61																				
7,5	1165	0160M0	13,7	7,65	90,2	91,0	90,5	86,0	0,76	0,69	0,57	0,35	61,4	2,85	2,50	2,90	91×10^{-3}	100	64																				
11	1170	0160L0	20,3	8,10	90,5	91,5	90,5	86,0	0,75	0,69	0,56	0,51	89,7	3,15	2,50	3,15	140×10^{-3}	121	64																				

8-pole

Power rating	Nominal speed	Frame size Type code ALAA...	Nominal current	Locked rotor current (multiple of nominal current)	Efficiency at load points				Power factor at load points				Nominal torque	Locked rotor torque (multiple of nominal torque)	Pull up torque (multiple of nominal torque)	Break down torque (multiple of nominal torque)	Moment of inertia	Total mass (B3 version; approx.)	Sound pressure; Noise level	
					η				$\cos \phi$											
					Full load	3/4 load	2/4 load	1/4 load	Full load	3/4 load	2/4 load	1/4 load								
P_N	n_n		I_N	I_l/I_N	η				$\cos \phi$				T_N	T_l/T_N	T_p/T_N	T_b/T_N	J	m	dB (A)	
[kW]	[rpm]		[A]		[%]								[Nm]				kgm ²	[kg]		
					Full load	3/4 load	2/4 load	1/4 load	Full load	3/4 load	2/4 load	1/4 load								
0,18	850	0080M0	0,84	3,10	56,5	53,0	44,5	27,0	0,48	0,41	0,33	0,24	2,02	2,00	2,00	2,45	$2,0 \times 10^{-3}$	13,0		
0,25	850	0080M1	1,11	3,10	59,5	56,0	48,0	30,0	0,48	0,41	0,33	0,24	2,81	2,00	2,00	2,45	$2,5 \times 10^{-3}$	14,0		
0,37	855	0090S0	1,17	4,20	68,5	66,0	59,0	42,0	0,58	0,50	0,40	0,28	4,13	2,00	2,00	2,55	$4,0 \times 10^{-3}$	20,0		
0,55	855	0090L0	1,79	4,05	69,0	67,5	61,0	43,5	0,56	0,48	0,38	0,26	6,14	2,05	2,00	2,50	$4,75 \times 10^{-3}$	22,0		
0,75	860	0100L0	2,23	4,55	74,0	73,5	70,5	56,0	0,57	0,49	0,38	0,24	8,32	2,30	2,00	2,30	$8,5 \times 10^{-3}$	27,0		
1,1	860	0100L1	3,06	4,75	77,0	77,0	74,0	61,0	0,59	0,50	0,39	0,24	12,2	2,30	2,00	2,30	$12,3 \times 10^{-3}$	33,0		
1,5	855	0112M0	3,80	4,75	80,0	80,0	76,0	64,0	0,62	0,53	0,40	0,25	16,8	2,10	1,95	2,60	$14,5 \times 10^{-3}$	38,0		
2,2	880	0132S0	4,78	7,30	82,5	82,5	80,0	69,5	0,70	0,61	0,48	0,30	23,9	2,25	1,85	3,30	34×10^{-3}	53,0		
3	885	0132M0	6,44	7,20	83,5	83,5	81,0	71,5	0,70	0,62	0,49	0,30	32,4	2,25	1,85	3,30	45×10^{-3}	64,0		
4	870	0160M0	8,56	6,45	85,0	84,5	82,0	72,5	0,69	0,60	0,47	0,30	43,9	1,90	1,80	2,65	86×10^{-3}	90,0		
5,5	870	0160M1	12,2	5,75	84,5	84,5	82,0	72,0	0,67	0,58	0,45	0,29	60,3	1,95	1,85	2,60	68×10^{-3}	107		
7,5	870	0160L1	16,4	6,10	86,5	86,0	83,5	74,5	0,67	0,58	0,44	0,29	82,3	2,20	2,10	2,90	147×10^{-3}	122		

6.3 Type data for cast iron version

6.3.1 Cast iron; 400 V; 50 Hz; Class IE2

2-pole

Power rating	Nominal speed	Frame size Type code ALAA...	Nominal current	Locked rotor current (multiple of nominal current)	Efficiency at load points				Power factor at load points				Nominal torque	Locked rotor torque (multiple of nominal torque)	Pull up torque (multiple of nominal torque)	Break down torque (multiple of nominal torque)	Moment of inertia	Total mass (B3 version; approx.)	Sound pressure; Noise level																			
																				P_N	n_n	I_N	I_l/I_N	η				$\cos \phi$				T_N	T_l/T_N	T_p/T_N	T_b/T_N	J	m	dB(A)
																				[kW]	[rpm]	[A]		[%]								[Nm]				kgm ²	[kg]	
																								Full load	3/4 load	2/4 load	1/4 load	Full load	3/4 load	2/4 load	1/4 load							
0,75	2850	0080M0	1,64	5,50	77,4	78,0	76,3	64,3	0,86	0,79	0,66	0,45	2,51	2,15	1,80	2,55	1,25 x 10 ⁻³	17	56																			
1,1	2875	0080M2	2,33	7,30	79,6	80,0	78,3	68,5	0,86	0,79	0,67	0,45	3,65	2,55	2,00	3,05	1,75 x 10 ⁻³	19,5	56																			
1,5	2880	0090S0	3,08	7,80	81,3	81,8	80,3	73,5	0,87	0,81	0,69	0,48	4,97	2,60	2,45	3,25	2,75 x 10 ⁻³	24,5	59																			
2,2	2875	0090L0	4,36	8,05	83,2	84,3	83,4	77,9	0,88	0,82	0,71	0,49	7,30	2,85	2,40	3,35	3,5 x 10 ⁻³	28	59																			
3	2895	0100L0	5,82	8,40	84,6	85,9	85,7	80,4	0,88	0,83	0,73	0,50	5,70	2,45	2,25	3,10	5,5 x 10 ⁻³	37,6	60																			
4	2880	0112M0	7,39	8,50	85,8	86,9	86,6	81,4	0,91	0,88	0,81	0,62	13,3	2,35	2,40	3,35	10,5 x 10 ⁻³	49	70																			
5,5	2925	0132S0	10,6	7,75	87,0	87,2	86,2	81,0	0,86	0,83	0,75	0,56	18,0	2,40	1,80	2,80	15,8 x 10 ⁻³	68	66																			
7,5	2920	0132S2	14,9	6,60	88,1	88,3	87,8	83,3	0,83	0,78	0,68	0,47	24,5	2,50	2,30	2,50	19 x 10 ⁻³	72,5	66																			
11	2950	0160M0	19,6	8,80	89,4	89,3	88,1	82,5	0,91	0,88	0,81	0,62	35,6	2,30	1,80	3,05	38 x 10 ⁻³	110	74																			
15	2930	0160M2	25,6	8,80	90,3	91,0	91,2	88,1	0,94	0,93	0,89	0,74	48,9	2,45	1,65	2,55	48 x 10 ⁻³	120	74																			
18,5	2925	0160L0	31,6	9,20	90,9	91,5	91,7	88,6	0,93	0,92	0,88	0,73	60,4	2,60	1,85	3,10	59 x 10 ⁻³	137	74																			
22	2930	0180M0	38,0	7,75	91,3	91,2	90,5	85,8	0,92	0,90	0,86	0,71	71,6	2,15	1,65	2,60	71 x 10 ⁻³	178	80																			
30	2945	0200L0	52,0	8,45	92,0	92,2	91,3	86,3	0,91	0,90	0,86	0,72	97,2	2,05	1,50	3,00	130 x 10 ⁻³	270	75																			
37	2945	0200L2	63,1	9,25	92,5	92,9	92,7	89,1	0,92	0,91	0,88	0,75	120	1,60	1,30	2,35	165 x 10 ⁻³	308	75																			
45	2965	0225M0	76,8	9,25	92,9	92,5	91,3	85,9	0,91	0,89	0,83	0,65	145	1,70	1,40	3,35	265 x 10 ⁻³	333	81																			
55	2970	0250M0	92,1	7,90	93,2	93,2	92,6	88,6	0,93	0,92	0,88	0,74	177	1,45	1,20	3,05	335 x 10 ⁻³	456	81																			
75	2965	0280S0	127	7,15	93,8	93,8	92,8	88,8	0,91	0,90	0,86	0,69	242	2,10	1,90	3,15	0,50	602	82																			
90	2965	0280M0	152	7,25	94,1	94,1	93,5	90,2	0,91	0,91	0,87	0,73	290	2,25	2,05	3,10	0,60	640	82																			
110	2965	0315S0	188	7,10	94,3	94,3	93,1	89,5	0,90	0,88	0,85	0,68	355	2,05	1,85	3,20	1,10	850	88																			
132	2965	0315M0	223	6,75	94,6	94,6	93,5	90,5	0,91	0,90	0,86	0,72	425	2,20	2,00	3,20	1,20	920	88																			
160	2970	0315M2	272	6,95	94,8	94,8	94,2	91,0	0,90	0,89	0,85	0,70	515	2,25	2,05	3,30	1,30	1000	90																			
200	2970	0315L0	334	6,95	95,0	95,0	94,2	91,3	0,91	0,91	0,88	0,75	645	2,30	2,15	3,15	1,60	1200	90																			
250	2970	0315D0	417	6,85	95,0	95,0	94,0	91,5	0,91	0,91	0,89	0,76	805	1,80	1,60	3,00	2,80	1690	90																			
315	2970	0315D2	520	6,80	95,0	95,0	94,3	91,7	0,92	0,92	0,89	0,74	1015	1,70	1,50	2,90	3,00	1830	92																			

4-pole

Power rating	Nominal speed	Frame size Type code ALAA...	Nominal current	Locked rotor current (multiple of nominal current)	Efficiency at load points				Power factor at load points				Nominal torque	Locked rotor torque (multiple of nominal torque)	Pull up torque (multiple of nominal torque)	Break down torque (multiple of nominal torque)	Moment of inertia	Total mass (B3 version; approx.)	Sound pressure; Noise level											
					η				$\cos \phi$																					
					P_N	n_n	I_N	I_l/I_N																T_N	T_l/T_N	T_p/T_N	T_b/T_N	J	m	dB (A)
					[kW]	[rpm]	[A]		Full load	3/4 load	2/4 load	1/4 load								Full load	3/4 load	2/4 load	1/4 load	[Nm]				kgm ²	[kg]	
0,55	1425	0080M0	1,40	5,70	78,1	78,0	75,1	64,1	0,73	0,62	0,48	0,30	3,69	2,90	2,60	3,05	2,5 x 10 ⁻³	17,5	52											
0,75	1415	0080M2	1,85	5,95	79,6	79,5	76,9	66,3	0,74	0,64	0,50	0,31	5,06	3,00	3,30	3,25	3,25 x 10 ⁻³	20,5	52											
1,1	1445	0090S0	2,57	7,40	81,4	81,4	78,9	69,8	0,76	0,67	0,53	0,34	7,26	2,70	2,05	3,25	4,25 x 10 ⁻³	25	52											
1,5	1435	0090L0	3,23	7,10	82,8	83,7	82,6	75,7	0,81	0,73	0,60	0,38	9,97	2,50	1,80	2,90	5,5 x 10 ⁻³	28	52											
2,2	1450	0100L0	4,62	7,15	84,3	85,0	84,1	76,1	0,82	0,74	0,61	0,39	14,5	1,95	1,55	2,65	10,2 x 10 ⁻³	37	51											
3	1445	0100L2	6,18	7,10	85,5	85,9	84,8	77,3	0,82	0,75	0,63	0,40	19,8	1,95	1,55	2,80	12,5 x 10 ⁻³	40	51											
4	1450	0112M0	7,84	7,40	86,6	87,6	87,5	83,2	0,85	0,81	0,71	0,48	26,3	2,20	2,00	2,70	21 x 10 ⁻³	54	51											
5,5	1455	0132S0	10,6	7,65	87,7	88,7	88,6	84,5	0,86	0,81	0,70	0,47	36,1	2,55	2,10	3,05	31 x 10 ⁻³	72	60											
7,5	1460	0132M0	14,5	7,70	88,7	89,6	89,5	85,3	0,84	0,79	0,67	0,45	49,1	2,75	2,00	3,05	36 x 10 ⁻³	79	60											
11	1465	0160M0	20,4	7,85	89,8	90,6	90,7	87,1	0,87	0,83	0,75	0,53	71,6	2,00	1,50	2,40	74 x 10 ⁻³	121	62											
15	1470	0160L0	27,6	7,95	90,6	91,3	91,2	88,1	0,87	0,83	0,74	0,52	97,3	2,20	1,55	2,55	107 x 10 ⁻³	138	62											
18,5	1475	0180M0	34,2	6,75	91,2	91,7	91,6	88,7	0,86	0,83	0,77	0,57	120	1,90	1,45	2,20	164 x 10 ⁻³	180	70											
22	1470	0180L0	40,5	6,65	91,6	92,4	92,2	89,3	0,86	0,84	0,78	0,58	143	1,85	1,45	2,10	193 x 10 ⁻³	199	70											
30	1470	0200L0	53,6	7,85	92,3	92,9	92,9	90,6	0,88	0,85	0,77	0,56	195	2,30	1,80	2,75	304 x 10 ⁻³	266	72											
37	1475	0225S0	65,8	6,55	92,7	93,3	93,3	90,3	0,88	0,86	0,80	0,62	239	1,85	1,50	2,60	410 x 10 ⁻³	333	75											
45	1480	0225M0	81,1	7,15	93,1	93,3	92,9	89,8	0,86	0,83	0,75	0,54	290	1,95	1,70	2,75	0,50	368	75											
55	1485	0250M0	97,0	8,05	93,5	93,7	93,3	90,0	0,88	0,85	0,79	0,60	354	2,45	1,80	2,65	0,90	492	80											
75	1480	0280S0	129	7,80	94,0	94,0	93,5	91,5	0,89	0,87	0,81	0,61	483	2,00	1,80	2,80	1,40	684	71											
90	1480	0280M0	156	7,90	94,2	94,2	93,7	91,7	0,89	0,87	0,79	0,59	580	2,00	1,80	2,80	1,60	716	71											
110	1482	0315S0	190	6,60	94,5	94,5	94,0	91,4	0,89	0,88	0,83	0,66	709	2,05	1,85	2,80	2,50	1020	75											
132	1482	0315M0	227	6,30	94,7	94,7	94,3	91,7	0,89	0,88	0,83	0,65	850	2,05	1,85	2,90	2,70	1070	79											
160	1481	0315M2	275	6,75	94,9	94,9	94,5	92,2	0,89	0,88	0,83	0,65	1030	2,00	1,80	2,85	2,90	1100	79											
200	1482	0315L0	343	6,55	95,1	95,1	94,7	92,5	0,89	0,87	0,83	0,66	1290	2,00	1,80	2,85	3,60	1280	83											
250	1485	0315D0	424	6,85	95,1	95,1	94,7	92,6	0,90	0,88	0,84	0,69	1610	2,10	1,85	2,80	6,30	1750	85											
315	1485	0315D2	534	6,80	95,1	95,1	94,7	92,6	0,90	0,88	0,85	0,71	2025	2,10	1,90	2,60	7,80	1920	85											

6-pole

Power rating	Nominal speed	Frame size Type code ALAA...	Nominal current	Locked rotor current (multiple of nominal current)	Efficiency at load points				Power factor at load points				Nominal torque	Locked rotor torque (multiple of nominal torque)	Pull up torque (multiple of nominal torque)	Break down torque (multiple of nominal torque)	Moment of inertia	Total mass (B3 version; approx.)	Sound pressure; Noise level	
					η				$\cos \varphi$											
					Full load	3/4 load	2/4 load	1/4 load	Full load	3/4 load	2/4 load	1/4 load								
P_N	n_n		I_N	I_l/I_N	η				$\cos \varphi$				T_N	T_l/T_N	T_p/T_N	T_b/T_N	J	m	dB(A)	
[kW]	[rpm]		[A]		[%]								[Nm]				kgm ²	[kg]		
					Full load	3/4 load	2/4 load	1/4 load	Full load	3/4 load	2/4 load	1/4 load								
0,37	915	0080M0	1,25	4,00	65,5	63,8	57,9	40,5	0,65	0,56	0,44	0,31	3,85	2,30	2,15	2,35	$2,3 \times 10^{-3}$	17,5	52	
0,55	915	0080M2	1,73	4,05	68,5	68,8	64,9	50,2	0,67	0,57	0,44	0,29	5,83	2,25	2,20	2,25	$3,0 \times 10^{-3}$	19,5	52	
0,75	935	0090S0	2,05	4,90	75,9	76,4	73,9	63,8	0,70	0,60	0,47	0,30	7,65	2,10	1,85	2,35	$4,8 \times 10^{-3}$	25	56	
1,1	930	0090L0	2,84	4,95	78,1	78,8	76,9	68,2	0,72	0,62	0,49	0,31	11,3	2,15	1,90	2,40	$6,5 \times 10^{-3}$	30	56	
1,5	950	0100L0	3,85	4,95	79,8	80,5	78,8	68,5	0,71	0,62	0,49	0,30	15,1	1,60	1,30	2,20	12×10^{-3}	39	51	
2,2	950	0112M0	5,18	6,55	81,8	82,4	81,1	72,6	0,75	0,67	0,53	0,34	22,1	2,80	2,55	2,90	18×10^{-3}	49	60	
3	960	0132S0	6,66	5,55	83,3	84,1	83,2	76,8	0,78	0,71	0,58	0,37	29,8	1,70	1,65	2,75	26×10^{-3}	61	55	
4	960	0132M0	8,64	6,15	84,6	85,6	85,1	79,3	0,79	0,73	0,60	0,39	39,7	1,90	1,80	2,80	33×10^{-3}	69	57	
5,5	960	0132M2	11,6	6,70	86,0	86,9	86,5	81,2	0,80	0,73	0,61	0,39	54,6	2,30	1,95	2,75	47×10^{-3}	81	57	
7,5	960	0160M0	15,1	6,95	87,2	88,2	87,7	82,4	0,82	0,77	0,67	0,45	74,6	2,10	1,95	2,35	91×10^{-3}	110	64	
11	965	0160L0	22,0	7,75	88,7	89,2	88,6	83,2	0,82	0,76	0,65	0,43	109	2,45	2,05	2,70	140×10^{-3}	138	64	
15	975	0180L0	29,3	7,50	89,7	90,4	90,2	86,7	0,83	0,78	0,68	0,46	147	2,10	1,95	2,50	335×10^{-3}	205	60	
18,5	980	0200L0	37,2	7,00	90,4	91,0	90,9	87,7	0,80	0,75	0,66	0,44	180	2,15	1,70	2,15	0,40	263	66	
22	980	0200L2	43,1	7,00	90,9	91,4	91,8	88,0	0,81	0,78	0,69	0,44	214	2,10	1,65	2,10	0,48	283	66	
30	980	0225M0	54,9	6,65	91,7	92,4	92,2	88,9	0,86	0,83	0,76	0,56	292	2,10	1,60	2,15	0,61	343	67	
37	980	0250M0	67,0	6,80	92,2	92,3	91,7	87,2	0,87	0,83	0,74	0,51	360	2,05	1,85	2,45	0,84	436	72	
45	980	0280S0	83,2	6,35	92,9	92,7	91,0	89,0	0,84	0,81	0,74	0,52	439	2,05	1,85	2,95	1,60	630	68	
55	985	0280M0	101	6,35	93,4	93,4	93,0	90,0	0,84	0,82	0,74	0,52	534	2,10	1,85	2,75	1,90	674	68	
75	985	0315S0	138	6,30	93,7	93,7	92,9	88,5	0,84	0,81	0,71	0,48	727	2,00	1,80	2,60	3,10	870	69	
90	985	0315M0	164	6,30	94,0	94,0	93,5	91,0	0,85	0,82	0,74	0,53	870	2,00	1,80	2,60	3,50	960	70	
110	985	0315M2	197	6,45	94,5	94,4	94,2	91,5	0,86	0,83	0,75	0,53	1063	2,05	1,85	2,70	4,70	1080	70	
132	985	0315L0	236	6,10	94,6	94,6	94,3	92,2	0,86	0,84	0,77	0,56	1276	2,05	1,85	2,75	5,10	1270	75	
160	985	0315L2	288	6,40	94,8	94,8	94,5	92,5	0,85	0,82	0,74	0,50	1550	2,10	1,90	2,75	5,80	1330	75	
200	985	0315D0	355	6,50	95,0	95,0	94,3	91,6	0,86	0,84	0,78	0,59	1938	2,10	1,90	2,80	9,70	1800	76	
250	985	0315D2	444	6,50	95,0	95,0	94,5	92,0	0,86	0,84	0,79	0,59	2425	2,00	1,80	2,70	11,6	1900	79	

8-pole

Power rating	Nominal speed	Frame size Type code ALAA...	Nominal current	Locked rotor current (multiple of nominal current)	Efficiency at load points				Power factor at load points				Nominal torque	Locked rotor torque (multiple of nominal torque)	Pull up torque (multiple of nominal torque)	Break down torque (multiple of nominal torque)	Moment of inertia	Total mass (B3 version; approx.)	Sound pressure; Noise level											
					η				$\cos \phi$																					
					P_N	n_n	I_N	I_L/I_N																T_N	T_L/T_N	T_P/T_N	T_B/T_N	J	m	dB (A)
					[kW]	[rpm]	[A]		Full load	3/4 load	2/4 load	1/4 load								Full load	3/4 load	2/4 load	1/4 load	[Nm]				kgm ²	[kg]	
0,18		0080M0																												
0,25		0080M2																												
0,37		0090S0																												
0,55		0090L0																												
0,75	695	0100L0	2,32	4,30	71,8	71,0	68,0	54,0	065	056	0,44	0,28	10,3	2,00	1,75	2,15	11,5 x 10 ⁻³	37,5												
1,1	690	0100L2	3,15	4,45	74,7	75,0	73,0	61,5	068	059	0,46	0,28	15,2	1,95	1,75	2,05	14,8 x 10 ⁻³	44,5												
1,5	700	0112M0	4,27	4,20	76,8	77,0	75,5	63,0	066	057	0,45	0,28	20,4	1,80	1,50	2,05	17,8 x 10 ⁻³	49,5												
2,2	710	0132S0	6,20	5,00	79,4	82,0	79,5	69,0	065	055	0,42	0,25	29,5	2,40	2,45	2,75	34,5 x 10 ⁻³	65,5												
3	700	0132M0	7,72	4,80	81,3	83,0	81,5	72,0	069	060	0,46	0,28	40,9	2,15	2,10	2,45	40 x 10 ⁻³	71												
4	715	0160M0	9,73	5,65	83,0	84,0	82,0	73,5	072	063	0,51	0,31	53,3	1,70	1,60	2,45	86 x 10 ⁻³	110												
5,5	715	0160M2	13,2	5,30	84,5	84,0	82,5	74,0	071	063	0,51	0,31	73,4	1,65	1,60	2,40	86 x 10 ⁻³	111												
7,5	720	0160L0	18,0	5,85	86,0	86,0	84,0	76,0	070	061	0,49	0,30	99,4	1,90	1,80	2,70	147 x 10 ⁻³	146												
11	720	0180L0	25,9	5,40	87,7	87,5	87,0	80,0	070	062	0,56	0,34	146	1,90	1,60	2,05	255 x 10 ⁻³	182												
15	720	0200L0	31,6	5,20	89,0	90,0	91,0	87,0	077	072	0,65	0,41	199	1,65	1,40	1,85	440 x 10 ⁻³	275												
18,5	735	0225S0	40,5	5,45	91,5	92,0	91,0	86,0	072	066	0,58	0,36	240	2,05	1,85	2,15	0,67	345												
22	735	0225M0	46,3	5,20	92,0	92,0	92,0	88,0	075	069	0,63	0,40	286	1,85	1,70	1,95	0,76	367												
30	735	0250M0	63,2	5,55	92,0	92,0	92,0	88,0	075	068	0,58	0,36	390	2,00	1,70	2,25	1,14	475												
37	735	0280S0	71,8	6,20	92,2	92,3	91,5	88,0	081	077	0,67	0,46	480	1,50	1,30	2,70	2,10	694												
45	735	0280M0	87,1	6,10	92,6	92,6	92,0	89,0	081	078	0,69	0,46	585	1,50	1,30	2,70	2,40	734												
55	738	0315S0	106	6,05	93,0	93,0	92,3	89,4	081	077	0,68	0,46	710	1,70	1,50	2,50	4,00	970												
75	738	0315M0	144	6,05	93,7	93,8	93,5	90,2	081	078	0,69	0,48	970	1,70	1,50	2,50	5,30	1080												
90	740	0315L0	172	6,00	94,0	94,0	93,7	90,7	081	078	0,69	0,48	1160	1,70	1,50	2,50	6,10	1180												
110	740	0315L2	209	6,10	94,5	94,5	94,1	91,0	081	079	0,70	0,48	1420	1,80	1,60	2,60	7,70	1320												
132	740	0315D0	250	6,40	94,6	94,6	94,2	91,2	081	076	0,66	0,43	1700	1,40	1,20	2,70	8,70	1700												
160	740	0315D2	302	6,75	94,8	94,8	94,3	91,7	081	076	0,65	0,43	2065	1,40	1,20	2,75	10,2	1800												
200	740	0315D4	377	6,50	95,0	95,0	94,5	92,5	081	076	0,66	0,43	2580	1,40	1,20	2,70	11,8	1950												

6.3.2 Cast iron; 400 V; 50 Hz; Class IE3

2-pole

Power rating	Nominal speed	Frame size Type code ALAA...	Nominal current	Locked rotor current (multiple of nominal current)	Efficiency at load points				Power factor at load points				Nominal torque	Locked rotor torque (multiple of nominal torque)	Pull up torque (multiple of nominal torque)	Break down torque (multiple of nominal torque)	Moment of inertia	Total mass (B3 version; approx.)	Sound pressure; Noise level																				
																				P_N	n_n	I_N	I_L/I_N	η				$\cos \varphi$				T_N	T_L/T_N	T_P/T_N	T_B/T_N	J	m	dB(A)	
																				[kW]	[rpm]	[A]		[%]								[Nm]					kgm ²	[kg]	
																								Full load	3/4 load	2/4 load	1/4 load	Full load	3/4 load	2/4 load	1/4 load								
0,75	2875	0080M1	1,59	7,55	80,7	78,3	75,1	63,0	84,5	78,0	0,67	0,47	2,49	2,80	2,75	3,35	1,5 x 10 ⁻³	17,5	52																				
1,1	2870	0080M3	2,26	7,95	82,7	83,0	81,3	73,8	0,85	0,79	0,67	0,45	3,66	3,00	2,95	3,50	1,75 x 10 ⁻³	19,5	57																				
1,5	2850	0090S1	2,84	7,75	84,2	85,4	85,8	81,0	0,91	0,87	0,78	0,58	5,02	2,20	2,10	2,80	3,0 x 10 ⁻³	25																					
2,2	2860	0090L1	4,13	8,45	85,9	86,7	86,8	82,2	90	0,85	0,76	0,54	7,33	2,45	2,35	3,15	3,5 x 10 ⁻³	28	59																				
3	2855	0100L1	5,52	8,70	87,1	88,3	88,4	84,9	0,90	0,87	0,79	0,59	5,70	3,25	3,10	3,55	6,3 x 10 ⁻³	38	55																				
4	2875	0112M1	7,20	9,60	88,1	89,0	88,9	85,5	0,91	0,88	0,80	0,61	13,3	2,70	2,50	3,60	11,5 x 10 ⁻³	50	59																				
5,5	2930	0132S1	10,1	7,90	89,2	89,8	89,5	85,5	0,89	0,86	0,80	0,58	17,9	2,05	2,05	3,40	18,8 x 10 ⁻³	70,5	63																				
7,5	2920	0132S3	13,8	7,25	90,1	90,9	90,8	87,7	0,87	0,85	0,78	0,59	24,5	1,95	1,95	3,15	20 x 10 ⁻³	75	63																				
11	2935	0160M1	19,3	7,75	91,5	92,5	92,5	89,5	0,90	0,89	0,84	0,70	35,7	2,30	1,85	2,85	46 x 10 ⁻³	123	67																				
15	2935	0160M3	26,5	8,70	91,9	92,0	92,0	88,0	0,89	0,86	0,78	0,58	48,8	2,75	2,30	3,30	50 x 10 ⁻³	126	67																				
18,5	2930	0160L1	32,1	8,10	92,4	93,0	93,0	91,0	0,90	0,90	0,84	0,68	60,3	2,45	2,00	2,95	59 x 10 ⁻³	137	75																				
22	2940	0180M1	39,2	7,70	93,0	93,0	93,0	89,0	0,87	0,85	0,77	0,53	71,6	2,25	1,80	2,75	71 x 10 ⁻³	178	71																				
30	2950	0200L1	51,6	7,75	93,5	93,5	92,5	91,5	0,90	0,90	0,87	0,74	97,1	2,00	1,45	2,70	150 x 10 ⁻³	276	75																				
37	2955	0200L3	62,4	8,20	94,0	95,0	94,5	92,5	0,91	0,91	0,87	0,75	119	1,95	1,45	2,80	185 x 10 ⁻³	302	73																				
45	2960	0225M1	75,9	8,10	94,0	94,0	93,5	90,0	0,91	0,91	0,88	0,71	146	1,50	1,40	2,90	295 x 10 ⁻³	350	81																				
55	2970	0250M1	91,3	8,05	95,0	95,0	95,0	92,0	0,92	0,90	0,87	0,72	177	1,50	1,30	3,15	385 x 10 ⁻³	476	75																				
75	2965	0280S1	126	7,20	94,7	94,5	93,0	90,0	0,91	0,90	0,86	0,68	242	1,50	1,30	2,40	0,60	640																					
90	2970	0280M1	151	7,30	95,0	95,0	94,6	91,5	0,91	0,89	0,83	0,64	289	1,50	1,35	2,40	0,70	666																					
110	2970	0315S1	184	7,25	95,2	95,0	94,3	90,5	0,91	0,89	0,85	0,68	354	1,50	1,25	2,40	1,20	960																					
132	2970	0315M1	220	6,80	95,4	95,2	94,8	92,0	0,91	0,91	0,88	0,74	424	1,30	1,20	2,30	1,30	1010																					
160	2975	0315M3	263	7,20	95,6	95,5	94,8	92,0	0,92	0,91	0,88	0,72	513	1,30	1,25	2,40	1,30	1060																					
200	2975	0315L1	328	7,05	95,8	95,8	95,5	92,6	0,92	0,92	0,90	0,77	643	1,30	1,00	2,40	1,70	1270																					
250	2975	0315D1	412	6,90	95,8	95,8	94,8	91,5	0,92	0,91	0,89	0,76	803	1,40	1,20	2,50	2,60	1800																					
315	2970	0315D3	516	7,30	95,8	95,5	94,7	91,5	0,92	0,92	0,91	0,80	1015	1,30	1,05	2,40	2,90	1900																					

4-pole

Power rating	Nominal speed	Frame size Type code ALAA...	Nominal current	Locked rotor current (multiple of nominal current)	Efficiency at load points				Power factor at load points				Nominal torque	Locked rotor torque (multiple of nominal torque)	Pull up torque (multiple of nominal torque)	Break down torque (multiple of nominal torque)	Moment of inertia	Total mass (B3 version; approx.)	Sound pressure; Noise level																				
																				P_N	n_n	I_N	I_l/I_N	η				$\cos \phi$				T_N	T_l/T_N	T_p/T_N	T_b/T_N	J	m	dB (A)	
																				[kW]	[rpm]	[A]		[%]								[Nm]					kgm ²	[kg]	
																								Full load	3/4 load	2/4 load	1/4 load	Full load	3/4 load	2/4 load	1/4 load								
0,55	1425	0080M1	0,98	9,20	79,0	77,9	74,7	63,2	0,69	0,59	0,45	0,28	3,69	3,00	2,70	3,20	2,5 x 10 ⁻³	17,5	54																				
0,75	1410	0080M3	1,79	6,15	82,5	81,8	79,7	71,6	0,74	0,64	0,50	0,32	5,07	3,15	2,90	3,35	3,25 x 10 ⁻³	20,5	54																				
1,1	1430	0090S1	2,37	7,40	84,1	84,4	83,2	76,4	0,80	0,72	0,58	0,37	7,33	2,55	2,05	2,90	4,75 x 10 ⁻³	26	55																				
1,5	1435	0090L1	3,38	7,70	85,3	84,1	82,2	74,3	0,75	0,66	0,52	0,32	9,97	3,00	2,35	3,35	5,5 x 10 ⁻³	28	56																				
2,2	1450	0100L1	4,52	7,30	86,7	87,3	86,9	80,4	0,81	0,74	0,61	0,38	14,5	2,00	1,60	2,70	11 x 10 ⁻³	38	60																				
3	1455	0100L3	6,33	7,75	87,7	87,7	86,2	78,9	0,78	0,71	0,58	0,37	19,7	2,50	2,40	3,35	13 x 10 ⁻³	40,5	59																				
4	1445	0112M1	7,95	7,15	88,6	88,4	87,9	83,0	0,82	0,77	0,66	0,44	26,4	2,45	2,05	2,80	21 x 10 ⁻³	54	61																				
5,5	1455	0132S1	10,4	7,40	89,6	90,4	90,3	86,9	0,85	0,81	0,70	0,48	36,1	2,45	2,00	3,00	33 x 10 ⁻³	74,5	63																				
7,5	1460	0132M1	14,2	7,75	90,4	90,8	90,4	87,0	0,85	0,80	0,69	0,46	49,1	2,70	2,25	3,30	43 x 10 ⁻³	85	64																				
11	1460	0160M1	20,7	7,75	91,4	92,0	91,5	88,0	0,84	0,80	0,70	0,49	71,7	2,30	1,85	2,70	92 x 10 ⁻³	126																					
15	1460	0160L1	27,8	8,10	92,1	92,5	92,5	89,0	0,85	0,81	0,71	0,49	97,4	2,50	1,95	2,85	115 x 10 ⁻³	146	64																				
18,5	1475	0180M1	35,4	7,65	92,6	94,0	93,0	90,0	0,82	0,77	0,70	0,46	120	2,15	1,60	2,55	175 x 10 ⁻³	190	70																				
22	1475	0180L1	42,2	7,45	93,0	93,5	93,0	90,0	0,81	0,77	0,71	0,47	142	1,90	1,45	2,45	198 x 10 ⁻³	204	70																				
30	1470	0200L1	53,3	8,35	94,1	95,0	95,0	93,0	0,86	0,85	0,77	0,56	195	2,50	2,05	2,80	363 x 10 ⁻³	288	72																				
37	1480	0225S1	66,4	7,60	94,1	95,0	94,5	92,0	0,86	0,82	0,73	0,50	237	2,10	1,75	3,00	470 x 10 ⁻³	354	68																				
45	1480	0225M1	81,3	7,40	94,5	95,0	94,5	92,0	0,85	0,80	0,70	0,47	290	2,10	1,75	2,90	0,50	368																					
55	1485	0250M1	95,5	7,85	95,0	95,0	94,5	91,0	0,88	0,85	0,77	0,55	354	2,10	1,85	2,65	0,98	508	75																				
75	1480	0280S1	128	7,10	95,0	95,0	94,2	91,8	0,89	0,88	0,82	0,63	483	1,60	1,35	2,50	1,60	710																					
90	1480	0280M1	154	7,15	95,2	95,0	94,5	91,5	0,89	0,87	0,81	0,62	580	1,80	1,50	2,50	1,80	744																					
110	1480	0315S1	188	7,25	95,4	95,2	94,8	92,0	0,89	0,87	0,81	0,61	710	1,60	1,35	2,50	2,90	1050																					
132	1480	0315M1	225	6,65	95,6	95,5	94,8	92,0	0,89	0,88	0,85	0,70	852	1,50	1,25	2,30	3,10	1100																					
160	1482	0315M3	268	6,90	95,8	95,8	95,0	92,5	0,90	0,89	0,84	0,65	1030	1,25	1,05	2,30	3,00	1220																					
200	1482	0315L1	334	6,80	96,0	95,8	95,3	93,2	0,90	0,90	0,85	0,67	1290	1,30	1,25	2,30	3,80	1400																					
250	1485	0315D1	413	7,15	96,0	95,8	95,0	92,6	0,91	0,90	0,88	0,75	1610	1,30	1,25	2,40	7,30	1950																					
315	1485	0315D3	518	7,35	96,0	96,0	95,5	93,5	0,92	0,91	0,89	0,76	2025	1,20	1,00	2,40	8,50	2090																					

6-pole

Power rating	Nominal speed	Frame size Type code ALAA...	Nominal current	Locked rotor current (multiple of nominal current)	Efficiency at load points				Power factor at load points				Nominal torque	Locked rotor torque (multiple of nominal torque)	Pull up torque (multiple of nominal torque)	Break down torque (multiple of nominal torque)	Moment of inertia	Total mass (B3 version; approx.)	Sound pressure; Noise level	
					η				$\cos \varphi$											
					Full load	3/4 load	2/4 load	1/4 load	Full load	3/4 load	2/4 load	1/4 load								
P_N	n_n		I_N	I_l/I_N	η				$\cos \varphi$				T_N	T_l/T_N	T_p/T_N	T_b/T_N	J	m	dB(A)	
[kW]	[rpm]		[A]		[%]								[Nm]				kgm ²	[kg]		
					Full load	3/4 load	2/4 load	1/4 load	Full load	3/4 load	2/4 load	1/4 load								
0,37	920	0080M1	1,17	4,25	70,0	69,0	64,8	49,9	0,65	0,55	0,42	0,28	3,83	2,30	2,10	2,50	$2,5 \times 10^{-3}$	18		
0,55	905	0080M3	1,64	3,65	70,0	69,7	66,2	52,1	0,69	0,58	0,45	0,29	5,85	2,10	1,95	2,25	$3,0 \times 10^{-3}$	19,5	52	
0,75	935	0090S1	1,93	4,65	78,9	80,6	79,4	70,1	0,71	0,63	0,49	0,30	7,65	2,05	1,90	2,25	$5,5 \times 10^{-3}$	27,5	52	
1,1	930	0090L1	2,72	4,80	81,0	81,2	80,5	74,4	0,72	0,64	0,50	0,31	11,3	2,00	1,85	2,15	$6,5 \times 10^{-3}$	30	54	
1,5	950	0100L1	3,62	4,95	82,5	82,9	81,5	73,9	0,73	0,65	0,52	0,33	15,1	2,00	1,75	2,25	14×10^{-3}	41	55	
2,2	960	0112M1	5,62	5,15	84,3	84,3	82,2	74,0	0,67	0,59	0,47	0,29	21,9	1,75	1,75	2,50	21×10^{-3}	52,5	59	
3	970	0132S1	6,36	6,45	85,6	86,1	85,1	79,5	0,80	0,73	0,60	0,38	29,5	1,75	1,70	3,00	38×10^{-3}	74	61	
4	970	0132M1	8,37	6,80	86,8	87,2	86,3	81,0	0,80	0,73	0,60	0,38	39,5	1,80	1,75	3,10	51×10^{-3}	84	61	
5,5	970	0132M3	12,3	7,15	88,0	88,0	86,2	79,4	0,74	0,66	0,52	0,32	54,1	2,10	2,05	3,45	54×10^{-3}	87	63	
7,5	970	0160M1	15,2	7,25	90,0	91,0	90,0	85,0	0,79	0,73	0,61	0,39	73,7	2,35	2,10	2,80	120×10^{-3}	130	63	
11	970	0160L1	22,5	7,55	90,3	91,0	90,5	86,0	0,78	0,72	0,61	0,38	109	2,95	2,55	2,85	157×10^{-3}	148	64	
15	970	0180L1	29,0	6,90	91,2	92,0	92,0	89,5	0,82	0,78	0,68	0,46	148	2,15	1,65	2,30	335×10^{-3}	205	67	
18,5	975	0200L1	36,1	7,20	92,0	93,0	93,0	90,0	0,81	0,76	0,67	0,44	181	2,20	1,85	2,40	0,46	281		
22	975	0200L3	42,3	7,20	92,2	93,0	93,5	91,0	0,82	0,77	0,68	0,45	215	2,10	1,85	2,40	0,52	293	69	
30	980	0225M1	55,8	6,00	93,0	94,0	94,0	91,0	0,84	0,80	0,77	0,53	292	2,00	1,60	2,15	0,76	375	70	
37	980	0250M1	67,3	7,30	93,3	94,0	94,0	91,0	0,85	0,82	0,75	0,52	360	2,30	2,00	2,50	1,05	458	73	
45	980	0280S1	81,6	6,50	93,7	93,7	93,0	90,5	0,85	0,82	0,74	0,52	439	1,40	1,25	2,30	1,90	675		
55	980	0280M1	99,3	6,45	94,1	94,0	93,5	90,5	0,85	0,82	0,74	0,52	536	1,50	1,25	2,40	2,40	730	70	
75	985	0315S1	135	6,65	94,6	94,5	93,7	90,5	0,85	0,82	0,73	0,51	727	1,60	1,35	2,40	3,70	1020		
90	985	0315M1	161	6,40	94,9	94,9	94,2	91,5	0,85	0,83	0,75	0,53	872	1,60	1,30	2,30	4,20	1050		
110	985	0315M3	199	6,95	95,1	95,0	94,5	91,5	0,84	0,80	0,71	0,49	1065	1,70	1,40	2,50	5,10	1150		
132	985	0315L1	230	6,50	95,4	95,4	95,0	92,8	0,87	0,86	0,79	0,57	1280	1,30	1,40	2,30	5,30	1350		
160	985	0315L3	278	6,70	95,6	95,6	95,0	93,8	0,87	0,85	0,78	0,57	1550	1,30	1,10	2,30	5,80	1450		
200	985	0315D1	342	7,15	95,8	95,8	95,4	93,5	0,88	0,87	0,80	0,60	1938	1,50	1,30	2,40	10,9	1970		
250	985	0315D3	428	7,10	95,8	96,0	95,5	94,2	0,88	0,86	0,81	0,60	2425	1,50	1,30	2,30	11,5	2010		

6.3.3 Cast iron; 460 V; 60 Hz; Class IE2

2-pole

Power rating	Nominal speed	Frame size Type code ALAA...	Nominal current	Locked rotor current (multiple of nominal current)	Efficiency at load points				Power factor at load points				Nominal torque	Locked rotor torque (multiple of nominal torque)	Pull up torque (multiple of nominal torque)	Break down torque (multiple of nominal torque)	Moment of Inertia	Total mass (B3 version; approx.)	Sound pressure; Noise level																			
																				P_N	n_n	I_N	I_1/I_N	η				$\cos \phi$				T_N	T_l/T_N	T_p/T_N	T_b/T_N	J	m	dB (A)
																				[kW]	[rpm]	[A]		Full load	3/4 load	2/4 load	1/4 load	Full load	3/4 load	2/4 load	1/4 load	[Nm]					kgm ²	[kg]
0,86	3450	0080M0	1,58	6,96	80,7	81	79	69,4	0,845	0,79	0,67	0,47	2,38	2,80	2,15	3,00	1,25 x 10 ⁻³	17	60																			
1,27	3465	0080M2	2,26	7,53	82,5	82,5	81	72,5	0,855	0,80	0,69	0,48	3,5	3,15	2,40	3,25	1,75 x 10 ⁻³	19,5	60																			
1,73	3475	0090S0	3,04	8,22	84,0	84,5	83,2	76,5	0,85	0,79	0,67	0,48	4,754	2,1	2,05	3,0	2,75 x 10 ⁻³	24,5	63																			
2,53	3480	0090L0	4,32	9,02	85,5	85,9	84,6	78,1	0,86	0,80	0,695	0,50	6,943	3,2	2,2	3,3	3,5 x 10 ⁻³	28	63																			
3,45	3490	0100L0	5,62	8,36	87,5	87,1	86,6	80,4	0,88	0,84	0,75	0,55	9,441	2,2	2,15	3,55	5,5 x 10 ⁻³	37,5	64																			
4	3485	0112M0	7,25	8,13	87,5	87,5	86,1	79	0,91	0,88	0,815	0,635	12,61	3,1	2,4	2,45	10,5 x 10 ⁻³	49	76																			
6,33	3525	0132S0	10,4	7,59	88,5	88,2	86,7	79,7	0,86	0,83	0,76	0,57	17,15	2,1	1,9	3	15,8 x 10 ⁻³	68	70																			
8,6	3525	0132S2	13,9	6,83	89,5	89,7	88,7	83,6	0,86	0,84	0,76	0,57	23,3	2,15	1,80	2,65	19 x 10 ⁻³	72,5	70																			
12,7	3545	0160M0	19,4	8,29	90,2	90,0	88,5	81,9	0,91	0,89	0,83	0,66	34,21	2,40	1,90	3,00	38 x 10 ⁻³	110	78																			
17,3	3535	0160M2	25,8	7,63	91,0	91,5	90,9	85,8	0,92	0,91	0,88	0,76	46,74	2,65	2,55	3,6	48 x 10 ⁻³	120	79																			
21,3	3535	0160L0	31,8	7,95	91,0	91,5	91,0	86,7	0,92	0,91	0,88	0,76	57,54	2,75	2,70	3,70	59 x 10 ⁻³	137	79																			
25,3	3540	0180M0	38,1	7,45	91,2	90,9	89,8	84,2	0,91	0,89	0,87	0,74	68,25	2,10	1,90	3,95	71 x 10 ⁻³	178	86																			
34,5	3545	0200L0	51,8	7,8	92,4	91,6	90,2	84,2	0,90	0,90	0,85	0,74	92,94	2,2	1,50	3,00	130 x 10 ⁻³	270	80																			
42,6	3550	0200L2	63,2	6,64	93,0	92,9	92,0	87,2	0,91	0,90	0,87	0,75	114,6	2,1	1,60	2,65	165 x 10 ⁻³	308	80																			
52	3565	0225M0	75,5	8,51	93,0	92,8	91,6	86,1	0,93	0,92	0,88	0,63	139,3	1,80	1,80	3,30	265 x 10 ⁻³	333	85																			
63	3550	0250M0	92,4	7,00	93,0	93,1	92,2	87,7	0,92	0,91	0,88	0,74	169,5	1,60	1,60	3,00	335 x 10 ⁻³	456	87																			
86	3570	0280S0	130	7,53	93,7	93,6	93,5	90,5	88,5	86,0	79,0	58,0	230	1,90	1,65	3,00	0,50	602	86																			
104	3570	0280M0	155	8,06	94,6	94,5	94,0	91,5	89,0	88,0	82,0	0,62	278,2	2,00	1,75	3,00	0,60	640	86																			
127	3575	0315S0	189	7,88	94,6	94,3	93,6	90,5	0,89	0,87	0,80	0,60	339,3	1,85	1,65	2,90	1,10	850	92																			
152	3575	0315M0	222	7,92	95,0	94,8	94,3	91,5	0,90	0,88	0,83	0,65	406	2,00	1,75	3,00	1,20	920	92																			
184	3575	0315M2	265	8,15	95,2	95,1	94,5	92	0,91	0,9	0,87	0,72	491	2,05	1,80	2,80	1,30	1000	92																			
230	3572	0315L0	329	7,9	95,4	95,0	93,6	89,8	0,92	0,91	0,89	0,77	614,9	2,25	2,00	2,75	1,60	1200	92																			
288	3573	0315D0	411	7,12	95,5	95,2	94	90,5	0,92	0,91	0,89	0,77	769,8	1,40	1,20	2,60	2,80	1690	93																			
362	3575	0315D2	517	9,97	95,6	95,4	94,2	90,5	0,92	0,91	0,89	0,77	967	1,60	1,40	3,00	3,00	1830	97																			

4-pole

Power rating	Nominal speed	Frame size Type code ALAA...	Nominal current	Locked rotor current (multiple of nominal current)	Efficiency at load points				Power factor at load points				Nominal torque	Locked rotor torque (multiple of nominal torque)	Pull up torque (multiple of nominal torque)	Break down torque (multiple of nominal torque)	Moment of inertia	Total mass (B3 version; approx.)	Sound pressure; Noise level																				
																				P_N	n_n	I_N	I_l/I_N	η				$\cos \varphi$				T_N	T_l/T_N	T_p/T_N	T_b/T_N	J	m	dB (A)	
																				[kW]	[rpm]	[A]		[%]								[Nm]					kgm ²	[kg]	
																								Full load	3/4 load	2/4 load	1/4 load	Full load	3/4 load	2/4 load	1/4 load								
0,63	1730	0080M0	1,36	7,35	81,2	79,8	76,1	64,0	0,71	0,63	0,48	0,31	3,47	3,15	2,8	3,45	$2,5 \times 10^{-3}$	17,5	56																				
0,86	1715	0080M2	1,87	6,95	82,5	81,1	77,9	68,0	70,0	0,60	0,46	0,29	4,789	3,05	2,80	3,50	$3,25 \times 10^{-3}$	20,5	56																				
1,27	1740	0090S0	2,45	8,16	84,0	83,6	81,0	70,9	0,77	0,69	0,56	0,36	6,970	2,75	2,20	3,35	$4,25 \times 10^{-3}$	25	56																				
1,73	1730	0090L0	3,23	7,43	84,0	84,7	83,7	76,9	0,80	0,73	0,61	0,40	9,55	2,50	1,60	3,00	$5,5 \times 10^{-3}$	28	59																				
2,53	1755	0100L0	4,48	7,58	87,5	87,0	86,5	79,2	0,81	0,74	0,61	0,33	13,77	2,05	1,55	3,00	$10,2 \times 10^{-3}$	37	55																				
3,45	1745	0100L2	6,04	7,61	87,5	87,5	87,4	80,9	0,82	0,76	0,64	0,41	18,88	2,00	1,40	3,00	$12,5 \times 10^{-3}$	40	56																				
4,6	1750	0112M0	7,68	7,81	89,5	89,5	88,8	83,4	0,84	0,79	0,69	0,47	25,10	2,15	1,95	3,25	21×10^{-3}	54	57																				
6,33	1760	0132S0	10,6	8,01	89,5	89,8	88,9	83,2	0,84	0,78	0,67	0,44	34,35	2,70	2,05	3,00	31×10^{-3}	72	64																				
8,6	1755	0132M0	14,2	8,02	89,5	89,9	89,4	84,6	0,85	0,80	0,70	0,48	46,80	2,65	2,00	3,00	36×10^{-3}	79	64																				
12,7	1765	0160M0	20,3	6,99	91	91,5	91,5	87,4	0,87	0,84	0,76	0,55	68,72	2,40	2,05	3,00	74×10^{-3}	121	68																				
17,3	1765	0160L0	27	7,59	92,5	92,5	92,5	89,6	0,87	0,84	0,76	0,54	93,61	2,55	2,00	3,00	107×10^{-3}	138	66																				
21,3	1765	0180M0	33,8	6,36	92,4	92,6	91,0	89,0	0,85	0,83	0,77	0,59	115,2	2,00	1,95	3,00	164×10^{-3}	180	74																				
25,3	1770	0180L0	40,4	5,89	92,4	93,0	92,7	89,1	0,85	0,84	0,78	0,59	136,5	2,00	1,95	3,00	193×10^{-3}	199	75																				
34,5	1770	0200L0	52,9	7,86	93	93,5	93,3	90,4	0,88	0,86	0,80	0,59	186,1	2,70	2,40	3,10	304×10^{-3}	266	78																				
42,6	1775	0225S0	66,0	6,21	93,6	93,5	92,7	88,4	0,87	0,85	0,79	0,60	229,2	2,05	1,90	3,30	410×10^{-3}	333	79																				
52	1780	0225M0	80,2	6,88	94,1	93,9	93,2	89,2	0,87	0,84	0,77	0,56	279	2,40	2,05	3,20	0,50	368	79																				
63	1785	0250M0	84,3	8,95	94,1	93,0	91,5	86,0	0,87	0,84	0,77	0,58	319	3,25	2,10	2,70	0,90	492	84																				
86	1780	0280S0	130	6,76	94,5	94,5	93,8	91,5	0,88	0,87	0,81	0,61	461,4	2,00	1,75	2,80	1,40	684	73																				
104	1782	0280M0	156	6,92	94,6	94,6	93,8	91,5	0,89	0,89	0,83	0,66	557	2,00	1,75	2,60	1,60	716	73																				
127	1785	0315S0	190	7,26	95,0	94,8	94,0	91,5	0,89	0,87	0,81	0,65	679	2,00	1,75	2,80	2,50	1020	80																				
152	1785	0315M0	226	7,03	95,0	95,0	94,3	92,2	0,89	0,87	0,82	0,64	813	2,00	1,75	2,80	2,70	1020	84																				
184	1785	0315M2	272	7,13	95,0	95,0	94,6	92,5	0,89	0,88	0,83	0,65	984	2,00	1,75	2,80	2,90	1070	84																				
230	1786	0315L0	338	7,13	95,4	95,3	94,2	91,5	0,90	0,89	0,84	0,68	1231	2,10	1,85	2,75	3,60	1280	85																				
288	1785	0315D0	421	7,32	95,5	95,3	94,4	91,8	0,90	0,89	0,85	0,70	1541	2,00	1,75	2,50	6,30	1750	87																				
362	1785	0315D2	529	7,18	95,5	95,3	94,4	91,8	0,90	0,89	0,86	0,71	1937	2,00	1,75	2,50	7,80	1920	90																				

6-pole

Power rating	Nominal speed	Frame size Type code ALAA...	Nominal current	Locked rotor current (multiple of nominal current)	Efficiency at load points				Power factor at load points				Nominal torque	Locked rotor torque (multiple of nominal torque)	Pull up torque (multiple of nominal torque)	Break down torque (multiple of nominal torque)	Moment of inertia	Total mass (B3 version; approx.)	Sound pressure; Noise level
					η				$\cos \varphi$										
					[%]														
					Full load	3/4 load	2/4 load	1/4 load	Full load	3/4 load	2/4 load	1/4 load							
P_N	n_n		I_N	I_l/I_N	η				$\cos \varphi$				T_N	T_l/T_N	T_p/T_N	T_b/T_N	J	m	dB (A)
[kW]	[rpm]		[A]		[%]								[Nm]				kgm ²	[kg]	
0,43	1115	0080M0	1,28	3,90	67,5	66,2	60,4	44,3	0,63	0,53	0,42	0,28	3,683	2,30	2,15	2,60	2,3 x 10 ⁻³	17,5	56
0,63	1110	0080M2	1,62	4,32	72,5	72,5	68,5	54,5	0,68	0,58	0,43	0,29	5,420	2,30	2,25	2,65	3,0 x 10 ⁻³	19,5	56
0,86	1140	0090S0	1,93	5,18	80,0	78,9	75,9	64,5	0,70	0,60	0,48	0,30	7,20	2,05	1,85	2,70	4,8 x 10 ⁻³	25	60
1,27	1140	0090L0	2,77	5,41	81,0	80,5	78,0	67,5	0,71	0,62	0,49	0,31	10,64	2,05	1,85	2,70	6,5 x 10 ⁻³	30	60
1,73	1155	0100L0	3,71	5,39	82,5	82,6	80,5	70,5	0,71	0,63	0,51	0,32	14,30	1,80	1,60	2,60	12 x 10 ⁻³	39	55
2,53	1155	0112M0	5,12	6,83	85,0	85,5	84,3	76,2	0,73	0,65	0,52	0,31	20,92	2,95	2,85	3,10	18 x 10 ⁻³	49	64
3,45	1165	0132S0	6,34	5,99	87,5	87,2	85,9	78,7	0,78	0,72	0,60	0,38	28,28	1,80	1,55	2,85	26 x 10 ⁻³	61	59
4,6	1165	0132M0	8,32	6,25	89,0	88	87,9	81,7	0,78	0,72	0,60	0,38	37,71	2,00	1,55	2,90	33 x 10 ⁻³	69	61
6,33	1165	0132M2	11,2	6,42	89,5	89,4	88,5	82,5	0,80	0,74	0,62	0,40	51,89	2,00	1,65	3,00	47 x 10 ⁻³	81	61
8,6	1165	0160M0	14,6	5,68	89,5	89,7	89,0	83,6	0,83	0,79	0,70	0,47	70,80	2,15	1,80	2,55	91 x 10 ⁻³	110	68
12,7	1170	0160L0	21,6	6,99	90,2	90,5	89,8	84,7	0,82	0,79	0,66	0,44	104,1	2,60	2,15	2,75	140 x 10 ⁻³	138	68
17,3	1175	0180L0	28,4	6,76	91,7	91,3	91,4	87,1	0,83	0,81	0,73	0,50	140,6	2,45	2,15	2,95	335 x 10 ⁻³	205	64
21,3	1175	0200L0	36,2	6,04	91,7	92,4	92,2	88,7	0,81	0,78	0,69	0,47	173,1	2,40	2,20	3,00	0,40	263	70
25,3	1175	0200L2	38,6	7,65	91,7	92,0	92,0	88,0	0,78	0,74	0,63	0,42	178	2,30	2,10	2,50	0,48	283	71
34,5	1180	0225M0	54,1	5,6	93,0	93,5	93,2	89,6	0,86	0,84	0,77	0,56	279	2,00	1,60	2,45	0,61	343	72
42,6	1185	0250M0	66	5,68	93,6	93,2	92,3	87,7	0,87	0,84	0,77	0,53	343	1,90	1,45	2,60	0,84	436	76
52	1186	0280S0	81,9	6,71	93,8	93,6	92,7	89,5	0,85	0,82	0,73	0,50	418,7	1,85	1,70	2,80	1,60	630	72
63	1186	0280M0	98,0	6,93	93,8	93,8	93,5	90,5	0,86	0,83	0,75	0,52	507,3	1,90	1,65	2,80	1,90	674	72
86	1185	0315S0	119	6,95	94,1	93,8	93,0	89,0	0,84	0,80	0,71	0,48	604	1,70	1,40	2,50	3,10	870	73
104	1185	0315M0	163	6,31	94,3	94,4	94	91,8	0,85	0,82	0,75	0,53	838,1	1,90	1,70	2,40	3,50	960	73
127	1185	0315M2	195	6,56	95,0	94,8	94,2	91,5	0,86	0,84	0,77	0,56	1024	2,00	1,75	2,40	4,70	1080	73
152	1185	0315L0	234	6,79	95,0	95	94,3	92,4	0,86	0,84	0,76	0,55	1225	2,10	1,85	2,40	5,10	1270	78
184	1186	0315L2	283	6,57	95,0	95,0	94,5	92,5	0,86	0,84	0,78	0,57	1482	2,20	1,95	2,55	5,80	1330	78
230	1185	0315D0	351	6,98	95,1	95	94,2	91,5	0,87	0,85	0,8	0,64	1854	2,00	1,75	2,50	9,70	1800	80
288	1185	0315D2	436	7,04	95,2	95,2	94,4	92,0	0,87	0,86	0,80	0,64	2321	2,05	1,80	2,50	11,6	1900	83

8-pole

Power rating	Nominal speed	Frame size Type code ALAA...	Nominal current	Locked rotor current (multiple of nominal current)	Efficiency at load points				Power factor at load points				Nominal torque	Locked rotor torque (multiple of nominal torque)	Pull up torque (multiple of nominal torque)	Break down torque (multiple of nominal torque)	Moment of inertia	Total mass (B3 version; approx.)	Sound pressure; Noise level											
					η				$\cos \varphi$																					
					P_N	n_n	I_N	I_l/I_N																T_N	T_l/T_N	T_p/T_N	T_b/T_N	J	m	dB (A)
					[kW]	[rpm]	[A]		Full load	3/4 load	2/4 load	1/4 load								Full load	3/4 load	2/4 load	1/4 load	[Nm]				kgm ²	[kg]	
0,18		0080M0																												
0,25		0080M2																												
0,37		0090S0																												
0,55		0090L0																												
0,86	850	0100L0	2,23	4,93	75,0	75,5	73,0	61,0	0,65	0,65	0,43	0,27	9,66	2,00	1,65	2,50	11,5 x 10 ⁻³	37,5												
1,27	845	0100L2	3,07	4,56	77,5	79,0	78,0	67,0	0,67	0,59	0,46	0,28	14,35	2,00	1,60	2,35	14,8 x 10 ⁻³	44,5												
1,73	850	0112M0	4,40	4,77	76,5	77,0	76,0	64,5	0,65	0,56	0,44	0,27	19,44	1,90	1,10	2,40	17,8 x 10 ⁻³	49,5												
2,53	855	0132S0	5,97	5,36	82,5	82,0	79,0	68,5	0,65	0,56	0,42	0,26	28,26	2,30	2,15	2,90	34,5 x 10 ⁻³	65,5												
3,45	850	0132M0	7,56	4,89	83,0	83,5	82,0	73,0	0,69	0,60	0,47	0,29	38,76	2,05	1,90	2,50	40 x 10 ⁻³	71												
4,6	865	0160M0	9,20	5,76	86,0	86,5	86,5	80,0	0,73	0,64	0,51	0,31	50,79	2,00	1,70	2,80	86 x 10 ⁻³	110												
6,33	865	0160M2	12,9	69,89	86,5	87,0	87,0	80,5	0,71	0,63	0,49	0,29	68,89	2,00	1,75	2,70	86 x 10 ⁻³	111												
8,6	870	0160L0	16,6	6,32	88,0	88,5	87,0	80,0	0,74	0,66	0,53	0,32	94,4	2,10	2,05	3,50	147 x 10 ⁻³	146												
12,7	870	0180L0	24,8	5,72	88,0	88,5	88,5	88,3	0,73	0,67	0,56	0,33	139,4	2,00	1,70	2,40	255 x 10 ⁻³	182												
17,3	870	0200L0	30,0	5,46	89,5	91,0	91,0	87,5	0,81	0,78	0,69	0,48	189	1,90	1,80	2,65	440 x 10 ⁻³	275												
21,3	880	0225S0	38,0	5,15	92,0	92,5	92,0	87,5	0,77	0,72	0,62	0,40	231	2,00	1,40	2,35	0,67	345												
25,3	880	0225M0	44,3	4,69	92,0	92,5	92,0	88,0	0,78	0,75	0,66	0,45	274	1,80	1,50	2,50	0,76	367												
34,5	885	0250M0	58,9	5,00	93,0	93,0	93,0	89,0	0,79	0,75	0,65	0,41	372	1,80	1,30	2,25	1,14	475												
42,6	885	0280S0	70,7	6,43	92,8	92,8	02,0	88,0	0,82	0,79	0,70	0,48	459	1,25	1,05	2,40	2,10	694												
52	885	0280M0	85,6	6,54	93,0	92,8	92,2	88,1	0,82	0,79	0,71	0,49	561	1,20	1,00	2,30	2,40	734												
63	885	0315S0	104	4,98	93,1	93,0	92,5	89,0	0,82	0,79	0,71	0,50	678	1,30	1,10	2,20	4,00	970												
86	885	0315M0	141	5,31	93,7	93,7	92,8	89,5	0,82	0,80	0,70	0,51	928	1,30	1,10	2,20	5,30	1080												
104	888	0315L0	170	5,41	94,2	94,1	93,2	90,1	0,82	0,80	0,72	0,51	1121	1,35	1,15	2,20	6,10	1180												
127	888	0315L2	207	6,03	94,5	94,4	93,6	90,8	0,82	0,8	0,72	0,51	1366	1,40	1,20	2,20	7,70	1320												
152	888	0315D0	247	6,23	94,8	94,8	94,0	91,0	0,82	0,79	0,70	0,48	1635	0,95	0,75	2,40	8,70	1700												
184	888	0315D2	298	4,48	95,0	94,9	94,5	91,0	0,82	0,79	0,70	0,46	1979	0,95	0,75	2,50	10,2	1800												
230	890	0315D4	370	6,24	95,1	95,1	94,5	91,5	0,82	0,79	0,72	0,48	2474	1,00	0,80	2,40	11,8	1950												

6.3.4 Cast iron; 460 V; 60 Hz; Class IE3

2-pole

Power rating	Nominal speed	Frame size Type code ALAA...	Nominal current	Locked rotor current (multiple of nominal current)	Efficiency at load points				Power factor at load points				Nominal torque	Locked rotor torque (multiple of nominal torque)	Pull up torque (multiple of nominal torque)	Break down torque (multiple of nominal torque)	Moment of inertia	Total mass (B3 version; approx.)										
					η				$\cos \phi$																			
					P_N	n_n	I_N	I_1/I_N	η										$\cos \phi$				T_N	T_l/T_N	T_p/T_N	T_b/T_N	J	m
					[kW]	[rpm]	[A]		[%]														[Nm]				kgm ²	[kg]
				Full load	3/4 load	2/4 load	1/4 load	Full load	3/4 load	2/4 load	1/4 load																	
0,86	3480	0080M1	1,57	8,9	81,6	80,5	76,7	65,1	0,84	0,78	0,67	0,48	2.360	2,95	2,85	3,70	1,5 x 10 ⁻³	17,5										
1,27	3470	0080M3	2,22	8,63	84	83,9	81,6	72,9	0,86	0,80	0,68	0,47	3.495	3,20	3,10	3,65	1,75 x 10 ⁻³	19,5										
1,73	3455	0090S1	2,82	8,15	85,5	86,7	86,5	81,5	0,90	0,86	0,77	0,58	4.782	2,95	2,10	3,00	3,0 x 10 ⁻³	25										
2,53	3460	0090L1	4,1	9,26	86,5	87,4	87	82,3	0,90	0,86	0,77	0,55	6.983	3,2	2,35	3,15	3,5 x 10 ⁻³	28										
3,45	3450	0100L1	5,44	8,63	88,5	89,4	89,2	84,6	0,90	0,88	0,80	0,52	9.55	2,95	2,85	3,35	6,3 x 10 ⁻³	38										
4,6	3470	0112M1	7,05	9,65	89,5	90,2	89,9	85,7	0,92	0,86	0,82	0,63	12.66	2,55	2,50	3,25	11,5 x 10 ⁻³	50										
6,33	3530	0132S1	10,1	7,82	89,5	89,7	88,9	84,2	0,88	0,85	0,79	0,60	17,13	2,10	2,05	3,00	18,8 x 10 ⁻³	70,5										
8,6	3520	0132S3	13,7	7,29	90,2	90,7	90,2	86,8	0,88	0,86	0,79	0,62	23,33	2,10	2,00	3,00	20 x 10 ⁻³	75										
12,7	3525	0160M1	19,0	8,15	91	91	90,1	85	0,92	0,91	0,88	0,75	34,41	2,15	1,90	3,00	46 x 10 ⁻³	110										
17,3	3535	0160M3	26	8,65	91,7	92	91,5	87,3	0,91	0,89	0,84	0,66	46,74	3,05	2,55	3,40	50 x 10 ⁻³	120										
21,3	3525	0160L1	31,3	8,46	91,7	92,4	92,3	89,0	0,93	0,90	0,87	0,72	57,71	2,55	2,10	3,00	59 x 10 ⁻³	137										
25,3	3540	0180M1	38,3	8,12	91,7	92,0	91,3	87,7	0,91	0,86	0,79	0,60	68,25	2,50	2,00	3,00	71 x 10 ⁻³	178										
34,5	3545	0200L1	51,2	7,81	93	92,9	92	87,5	0,91	0,9	0,88	0,78	92,94	2,00	1,60	2,20	150 x 10 ⁻³	276										
42,6	3550	0200L3	62,8	8,12	93,6	93,8	93,6	90,2	0,91	0,91	0,88	0,78	114,6	2,05	1,50	2,55	185 x 10 ⁻³	302										
51,8	3560	0225M1	74,7	8,29	93,6	93,6	92,8	88,4	0,93	0,93	0,93	0,80	139	1,80	1,75	3,00	295 x 10 ⁻³	333										
63	3565	0250M1	91,3	8,1	93,6	93,9	93,3	90,8	0,93	0,92	0,89	0,76	168	2,10	1,60	3,00	385 x 10 ⁻³	456										
86	3570	0280S1	125,5	6,93	94,5	94,5	93,8	90,8	0,91	0,90	0,86	0,69	230	1,20	1,00	3,00	0,60	705										
104	3570	0280M1	151	7,48	95,0	95,0	94,4	91,0	0,91	0,90	0,85	0,68	278,2	1,40	1,15	3,10	0,70	740										
127	3575	0315S1	184	7,28	95,2	95,2	94,5	91	0,91	0,90	0,85	0,69	339	1,30	1,05	3,00	1,20	970										
152	3575	0315M1	218	6,83	95,6	95,5	94,8	91,5	0,92	0,91	0,88	0,74	406	1,30	1,05	2,80	1,30	1025										
184	3577	0315M3	262	7,00	95,8	95,6	94,5	91,5	0,92	0,92	0,89	0,75	491	1,10	1,15	2,70	1,30	1075										
230	3578	0315L1	325	7,84	95,8	95,6	94,5	91,5	0,93	0,92	0,90	0,80	613	1,10	1,15	2,50	1,70	1270										
288	3578	0315D1	407	7,24	95,8	95,6	94,5	91,5	0,93	0,92	0,91	0,81	768	1,10	1,15	2,60	2,60	1765										
362	3578	0315D3	508	7,36	96,0	95,8	94,6	91,5	0,93	0,93	0,92	0,82	966	1,10	1,15	2,60	2,90	1885										

4-pole

Power rating	Nominal speed	Frame size Type code ALAA...	Nominal current	Locked rotor current (multiple of nominal current)	Efficiency at load points				Power factor at load points				Nominal torque	Locked rotor torque (multiple of nominal torque)	Pull up torque (multiple of nominal torque)	Break down torque (multiple of nominal torque)	Moment of inertia	Total mass (B3 version; approx.)	
					η				$\cos \varphi$										
					Full load	3/4 load	2/4 load	1/4 load	Full load	3/4 load	2/4 load	1/4 load							
P_N	n_n		I_N	I_l/I_N	η				$\cos \varphi$				T_N	T_l/T_N	T_p/T_N	T_b/T_N	J	m	
[kW]	[rpm]		[A]		[%]								[Nm]				kgm ²	[kg]	
					Full load	3/4 load	2/4 load	1/4 load	Full load	3/4 load	2/4 load	1/4 load							
0,63	1725	0080M1	1,41	6,38	80,0	78,8	74,3	61,3	0,70	0,63	0,48	0,31	3,48	3,25	2,95	3,55	$2,5 \times 10^{-3}$	17,5	
0,86	1710	0080M3	1,74	6,89	84,0	83,6	81,4	73,6	0,74	0,65	0,51	0,32	4,80	3,70	3,40	3,55	$3,25 \times 10^{-3}$	20,5	
127	1730	0090S1	2,39	7,12	85,5	86,1	84,6	78,0	0,78	0,70	0,58	0,38	7,01	2,50	1,95	3,00	$4,75 \times 10^{-3}$	26	
1,73	1735	0090L1	3,36	7,44	85,5	85,7	83,9	76,9	0,76	0,67	0,53	0,33	9,52	2,80	2,20	3,30	$5,5 \times 10^{-3}$	28	
2,53	1760	0100L1	4,82	8,50	88,5	88,1	86,9	79,2	0,75	0,66	0,52	0,32	13,73	2,45	1,95	3,50	11×10^{-3}	38	
3,45	1750	0100L3	6,15	8,13	88,5	88,5	87,1	80,7	0,79	0,72	0,60	0,39	18,83	2,25	2,20	3,40	13×10^{-3}	40,5	
4,6	1740	0112M1	7,96	7,16	88,5	89,2	88,8	84,3	0,82	0,78	0,67	0,45	25,25	2,20	1,75	3,00	21×10^{-3}	54	
6,33	1755	0132S1	10,1	7,72	91,7	92,1	91,9	88,0	0,86	0,81	0,71	0,48	34,45	2,55	2,05	3,30	33×10^{-3}	74,5	
8,6	1760	0132M1	13,8	8,18	91,7	92,2	91,9	88,7	0,86	0,81	0,71	0,49	46,66	2,85	2,35	3,50	43×10^{-3}	85	
12,7	1760	0160M1	19,8	8,33	92,4	93,0	92,9	90,1	0,87	0,84	0,76	0,55	68,91	2,55	2,40	3,55	92×10^{-3}	133	
17,3	1755	0160L1	26,8	9,51	93,0	93,5	93,4	90,9	0,87	0,84	0,76	0,55	94,14	2,85	2,80	3,85	115×10^{-3}	138	
21,3	1770	0180M1	34,6	7,65	93,6	94	93,5	90,1	0,83	0,79	0,71	0,50	114,9	2,30	2,25	3,55	175×10^{-3}	183	
25,3	1770	0180L1	41,4	7,48	93,6	94,0	93,5	90,3	0,82	0,79	0,71	0,49	136,5	2,35	2,30	3,55	198×10^{-3}	199	
34,5	1770	0200L1	51,7	7,93	94,1	94,5	94,3	92,3	0,89	0,87	0,82	0,65	186	2,10	1,95	3,00	363×10^{-3}	266	
42,6	1780	0225S1	65,8	7,75	94,5	94,7	94,1	90,4	0,86	0,83	0,76	0,54	228	2,10	1,90	3,10	470×10^{-3}	333	
51,8	1775	0225M1	80	7,75	94,5	94,5	94,1	90,9	0,86	0,84	0,77	0,55	278,7	2,35	2,00	2,95	0,50	368	
63	1780	0250M1	94,6	7,98	95	95	94,2	90,6	0,88	0,86	0,79	0,57	338	2,40	2,05	3,00	0,98	492	
86	1780	0280S1	126	6,88	95,4	95,4	94,2	91,0	0,90	0,89	0,84	0,67	461	1,70	1,45	2,60	1,60	710	
104	1780	0280M1	152	7,23	95,4	95,4	94,5	91,5	0,90	0,89	0,84	0,67	558	1,80	1,55	2,60	1,80	755	
127	1785	0315S1	185,9	7,47	95,8	95,7	94,5	91,5	0,90	0,89	0,83	0,65	679	1,80	1,55	2,80	2,90	1080	
152	1783	0315M1	222	6,23	95,8	95,5	94,5	91,5	0,90	0,89	0,86	0,72	814	1,50	1,25	2,30	3,10	1100	
184	1785	0315M3	265	6,94	96,2	96,0	94,6	92,0	0,91	0,90	0,86	0,70	984	1,10	1,15	2,40	3,00	1220	
230	1788	0315L1	329	6,71	96,2	96,0	94,8	92,0	0,91	0,90	0,87	0,72	1228	1,10	1,15	2,30	3,80	1400	
288	1788	0315D1	410	7,46	96,2	96,0	95,0	92,2	0,92	0,91	0,89	0,75	1538	1,10	1,15	2,40	7,30	1990	
362	1788	0315D3	514	7,46	96,0	95,8	95,0	92,2	0,92	0,92	0,90	0,77	1934	1,10	1,15	2,50	8,50	2110	

6-pole

Power rating	Nominal speed	Frame size Type code ALAA...	Nominal current	Locked rotor current (multiple of nominal current)	Efficiency at load points				Power factor at load points				Nominal torque	Locked rotor torque (multiple of nominal torque)	Pull up torque (multiple of nominal torque)	Break down torque (multiple of nominal torque)	Moment of inertia	Total mass (B3 version; approx.)										
					η				$\cos \phi$																			
					P_N	n_n	I_N	I_l/I_N															T_N	T_l/T_N	T_p/T_N	T_b/T_N	J	m
					[kW]	[rpm]	[A]		[%]														[Nm]				kgm ²	[kg]
					Full load	3/4 load	2/4 load	1/4 load	Full load	3/4 load	2/4 load	1/4 load																
0,43	1120	0080M1	1,10	4,54	76,0	76,4	73,1	59,5	0,65	0,55	0,43	0,27	3,67	2,25	2,20	2,55	2,5 x 10 ⁻³	18										
0,63	1110	0080M3	1,56	4,48	76,0	76,4	73,5	60,2	0,67	0,57	0,44	0,28	5,42	2,10	2,05	2,40	3,0 x 10 ⁻³	19										
0,86	1140	0090S1	1,86	5,37	82,5	83,8	82,7	73,0	0,71	0,62	0,49	0,30	7,204	1,95	1,70	2,50	5,5 x 10 ⁻³	27,5										
1,27	1130	0090L1	2,68	4,80	82,5 (*)	83,3	82,6	77,3	0,72	0,62	0,51	0,32	10,73	1,85	1,65	2,35	6,5 x 10 ⁻³	30										
1,73	1150	0100L1	3,54	5,08	84,0 (*)	84,2	82,7	75,5	0,73	0,66	0,53	0,34	14,37	2,00	1,55	2,40	14 x 10 ⁻³	41										
2,53	1155	0112M1	5,44	5,14	86,5 (*)	86,5	84,7	77,5	0,68	0,60	0,48	0,30	20,92	1,65	1,60	2,70	21 x 10 ⁻³	52,5										
3,45	1165	0132S1	6,28	6,52	89,5	89,5	88,1	82,7	0,77	0,70	0,57	0,37	28,28	1,9	1,65	3,00	38 x 10 ⁻³	74										
4,6	1170	0132M1	8,26	7,38	90,2	90,4	88,9	83,8	0,76	0,71	0,58	0,37	37,55	2,1-0	1,70	3,00	51 x 10 ⁻³	84										
6,33	1170	0132M3	11,8	7,37	90,2	90,0	88,6	82,6	0,75	0,67	0,54	0,33	51,67	2,10	1,85	3,30	54 x 10 ⁻³	87										
8,6	1170	0160M1	14,8	7,43	91,0	91,5	91,0	86,4	0,80	0,75	0,65	0,43	70,2	2,35	2,10	3,00	120 x 10 ⁻³	110										
12,7	1170	0160L1	21,5	7,95	91,7	92,0	91,7	87,4	0,81	0,76	0,65	0,42	103,7	2,45	2,20	3,00	157 x 10 ⁻³	138										
17,3	1165	0180L1	28,4	7,21	91,7	92,3	92,6	89,7	0,83	0,81	0,73	0,51	141	2,25	2,00	2,80	335 x 10 ⁻³	205										
21,3	1175	0200L1	35,1	7,69	93,0	93,4	93,3	90,0	0,82	0,78	0,70	0,48	173	2,55	1,95	2,60	0,46	263										
25,3	1175	0200L3	41,6	7,69	93	93,5	93,5	90,5	0,82	0,79	0,71	0,49	205	2,45	1,90	2,50	0,52	283										
34,5	1175	0225M1	53,5	6,35	93,0	93,7	93,7	90,6	0,87	0,86	0,81	0,61	280	1,75	1,20	2,10	0,76	343										
42,6	1180	0250M1	64,9	7,70	94,1	94,3	94,0	90,7	0,88	0,86	0,80	0,59	344	2,20	1,95	2,50	1,05	458										
51,8	1185	0280S1	80,9	6,18	94,5	94,5	93,5	90,5	0,85	0,83	0,76	0,55	417	1,50	1,25	2,60	1,90	675										
63	1185	0280M1	98,1	6,44	94,6	94,5	93,5	90,6	0,85	0,83	0,76	0,55	507,7	1,60	1,35	2,70	2,40	745										
86	1185	0315S1	132	6,81	95,0	95,0	93,6	90,8	0,86	0,83	0,77	0,55	693	1,80	1,55	2,60	3,70	985										
104	1185	0315M1	160	6,87	95,2	95,0	94,0	91,0	0,86	0,84	0,78	0,57	838	1,80	1,55	2,40	4,20	1065										
127	1188	0315M3	194	7,16	95,8	95,8	94,2	91,5	0,86	0,83	0,76	0,54	1021	2,10	1,85	2,70	5,10	1170										
152	1188	0315L1	227	6,51	95,8	95,8	94,5	91,5	0,88	0,86	0,80	0,61	1222	1,10	1,15	2,30	5,30	1345										
184	1188	0315L3	275	6,56	95,9	96,0	94,6	92,0	0,88	0,86	0,80	0,61	1479	1,10	1,15	2,30	5,80	1435										
230	1188	0315D1	341	7,14	96,0	96,0	94,8	92,0	0,88	0,87	0,81	0,61	1849	1,30	1,38	2,40	10,9	1930										
288	1188	0315D3	427	7,16	96,0	96,0	95,0	92,2	0,88	0,87	0,82	0,62	2315	1,20	1,26	2,30	11,5	2010										

7 Outline drawings

7.1 Aluminium design

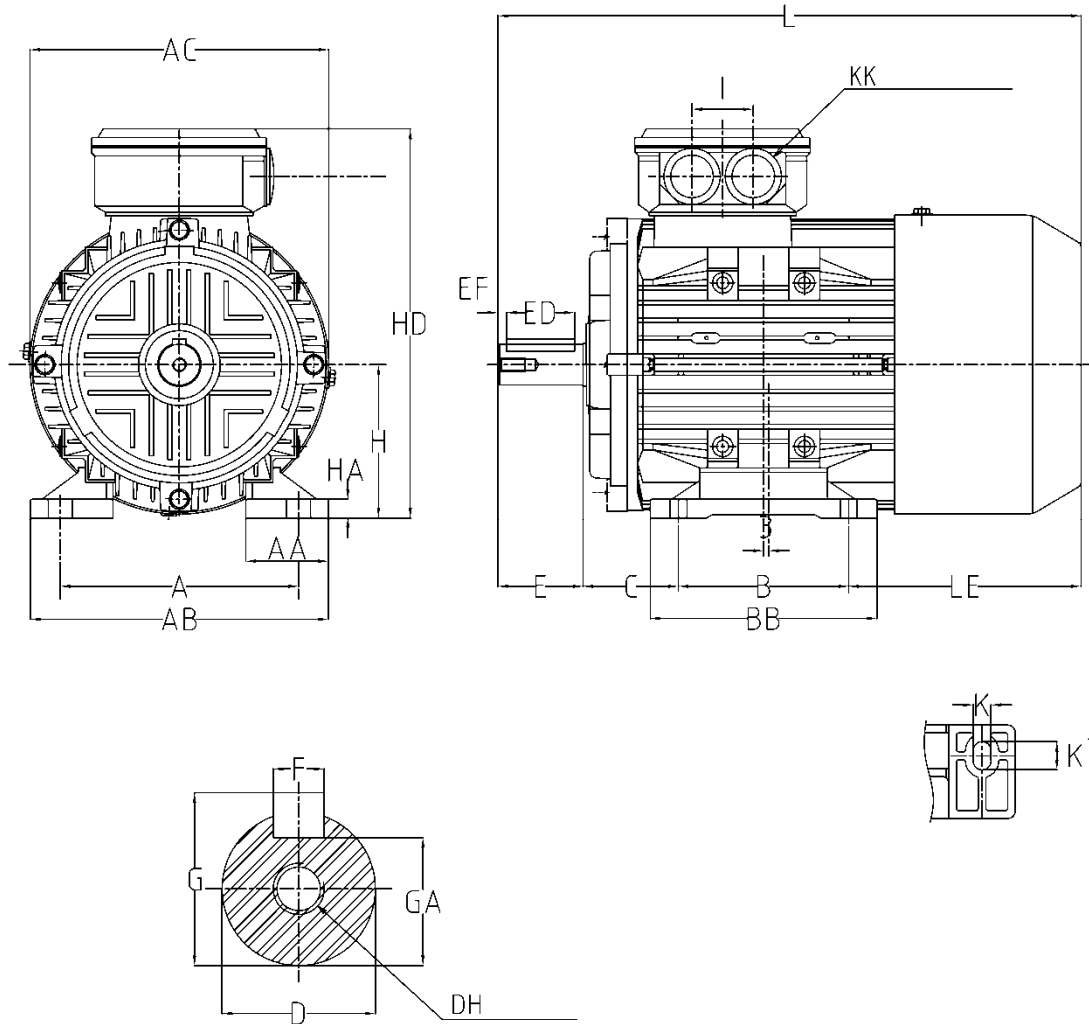

Figure 7-1: Outline drawing of aluminium design, feet version, mounting B3, frame size 63 – 160 (sample)

Frame size	Outline dimensions of aluminium design, feet version (mounting B3), dimensions in [mm]															
	A	AA	AB	AC	B	BB	C	H	HA	HD	K	K'	KK	I	L	
63	S												2 M16 x1,5			
	M	100	35,5	125	120	80	105	40	63	9	171	10		14	28	220,5
	L															
71	S												2 M16 x1,5			
	M	112	36,5	136	136	90	116	45	71	9	187	10		14	28	245
	L															
80	S												2 M25 x1,5			
	M	125	42,5	158	159	100	126	50	80	9	208	10		14	28	314
	L															
90	S	140	49	175	176	100	133	56	90	11	228	10	14	2 M25 x1,5	38	343
	M														38	368
	L	140	49	175	176	125	155	56	90	11	228	10	14			
100	S												2 M25 x1,5			
	M															
	L	160	52	196	198	140	174	63	100	12	248	12		16	38	404
112	S												M25 x1,5 + M32 x1,5			
	M	190	59	225	220	140	177	70	112	14	277	12		16	40	415
	L															
132	S	216	63,5	254	258	140	180	89	132	16	317	12	16	2 M40 x1,5+ 1 M20 x1,5	40	462
	M	216	63,5	254	258	178	224	89	132	16	317	12	16		40	500
	L															
160	S												2 M40 x1,5+ 1 M20 x1,5			
	M	254	54	290	314	210	294	108	160	16	392	15		19	56	643
	L	254	54	290	314	254	294	108	160	16	392	15		19	56	643

Frame size	Shaft extension									Bearings			
	LE	D	E	ED	EF	F	G	GA	DH	at DE	at NDE	Figure	
63	S									M4 x 8			
	M	77,5	11 j6	23	16	4	4	8,5	12,5		6201ZZC3	6201ZZC3	7-1
	L												
71	S									M5 x 10			
	M	80	14 j6	30	22	4	5	11	16		6202ZZC3	6202ZZC3	7-1
	L												
80	S									M6 x 12			
	M	124	19 j6	40	32	4	6	15,5	21,5		6204ZZC3	6204ZZC3	7-1
	L												
90	S	137	24 j6	50	40	5	8	20	27	M8 x 16	6205ZZC3	6205ZZC3	7-1
	M										6205ZZC3	6205ZZC3	7-1
	L	137	24 j6	50	40	5	8	20	27				
100	S									M10 x 20			
	M												
	L	141	28 j6	60	50	5	8	24	31		6206ZZC3	6305ZZC3	7-1
112	S									M10 x 20			
	M	145	28 j6	60	50	5	8	24	31		6306ZZC3	6306ZZC3	7-1
	L												
132	S	153	38 k6	80	70	5	10	33	41	M12 x 24	6308ZZC3	6308ZZC3	7-1
	M	153	38 k6	80	70	5	10	33	41		6308ZZC3	6308ZZC3	7-1
	L												
160	S									M16 x 32			
	M	171	42 k6	110	100	5	12	37	45		6309ZZC3	6309ZZC3	7-1
	L	171	42 k6	110	100	5	12	37	45		6309ZZC3	6309ZZC3	7-1

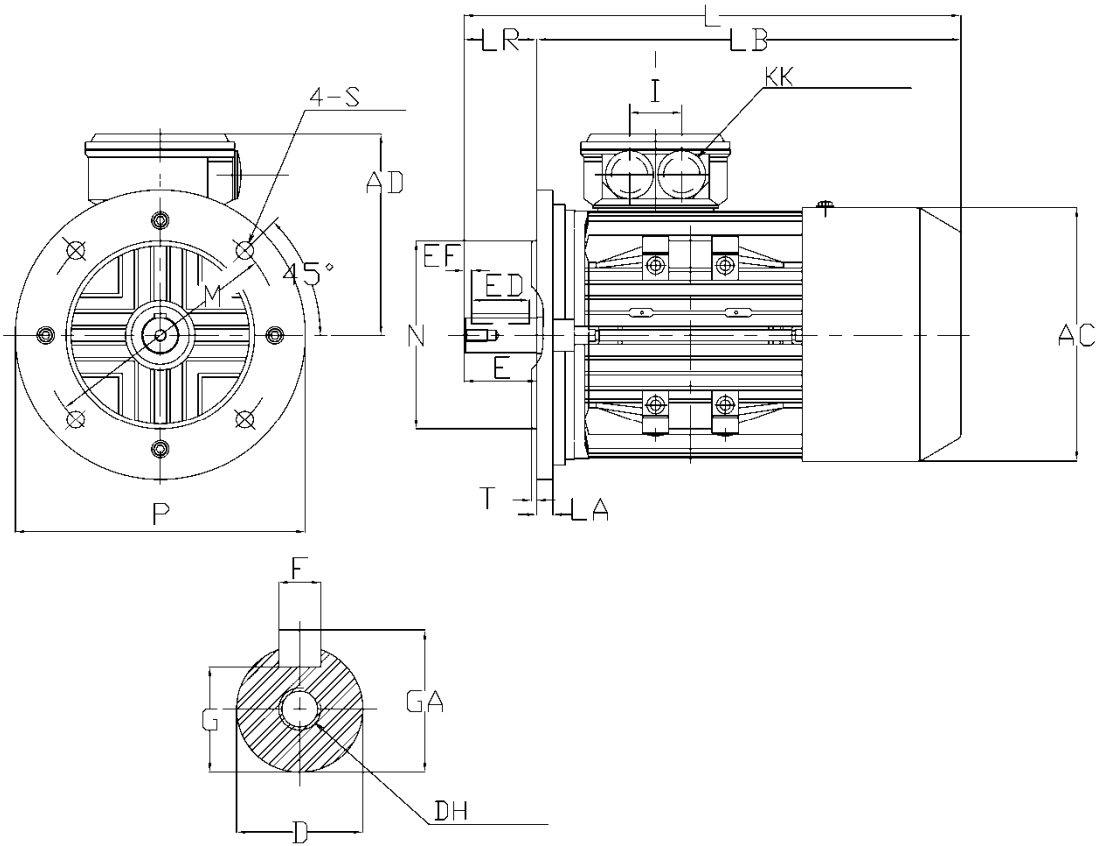

Figure 7-2: Outline drawing of aluminium design, flange version, mounting B5, frame size 63 – 160 (sample)

Frame size		Outline drawing of aluminium design, flange version, mounting B5, frame size 63 – 160, dimensions in [mm]														
		AC	AD	KK	LA	LB	LR	M	N	P	S	T	I	L		
63	S			2 M16 x1,5												
	M	120	108		9	197,5	23	115	95	140	Ø 10	3	28	220,5		
	L															
71	S				2 M25 x1,5											
	M	136	116			10	215	30	130	110	160	Ø 10	3,5	28	245	
	L															
80	S			2 M25 x1,5												
	M	159	129			10	274	40	165	130	200	Ø 12	3,5	28	314	
	L															
90	S	176	139		2 M25 x1,5	11	293	50	165	130	200	Ø 12	3,5	38	343	
	M															
	L	176	139			11	318	50	165	130	200	Ø 12	3,5	38	368	
100	S			2 M40 x1,5+ M20 x1,5												
	M															
	L	198	149			14	344	60	215	180	250	Ø 14,5	4	38	404	
112	S				M25 x1,5 + M32 x1,5											
	M	220	167			14	355	60	215	180	250	Ø 14,5	4	40	415	
	L															
132	S	258	186	M25 x1,5 + M32 x1,5		15,5	382	80	265	230	300	Ø 14,5	4	40	462	
	M	258	186			15,5	420	80	265	230	300	Ø 14,5	4	40	500	
	L															
160	S				2 M40 x1,5+ M20 x1,5											
	M	314	232			16	533	110	300	250	350	Ø 18,5	5	56	643	
	L	314	232			16	533	110	300	250	350	Ø 18,5	5	56	643	

Frame size		Shaft extension							Bearings			
		D	E	ED	EF	F	G	GA	DH	at DE	at NDE	Figure
63	S								M4 x 8			
	M	11 j6	23	16	4	4	8,5	12,5		6201ZZC3	6201ZZC3	7-2
	L											
71	S								M5 x 10			
	M	14 j6	30	22	4	5	11	16		6202ZZC3	6202ZZC3	7-2
	L											
80	S								M6 x 12			
	M	19 j6	40	32	4	6	15,5	21,5		6204ZZC3	6204ZZC3	7-2
	L											
90	S	24 j6	50	40	5	8	20	27	M8 x 16	6205ZZC3	6205ZZC3	7-2
	M											
	L	24 j6	50	40	5	8	20	27		6205ZZC3	6205ZZC3	7-2
100	S								M10 x 20			
	M											
	L	28 j6	60	50	5	8	24	31		6206ZZC3	6305ZZC3	7-2
112	S								M10 x 20			
	M	28 j6	60	50	5	8	24	31		6306ZZC3	6306ZZC3	7-2
	L											
132	S	38 k6	80	70	5	10	33	41	M12 x 24	6308ZZC3	6308ZZC3	7-2
	M	38 k6	80	70	5	10	33	41		6308ZZC3	6308ZZC3	7-2
	L											
160	S								M16 x 32			
	M	42 k6	110	100	5	12	37	45		6309ZZC3	6309ZZC3	7-2
	L	42 k6	110	100	5	12	37	45		6309ZZC3	6309ZZC3	7-2

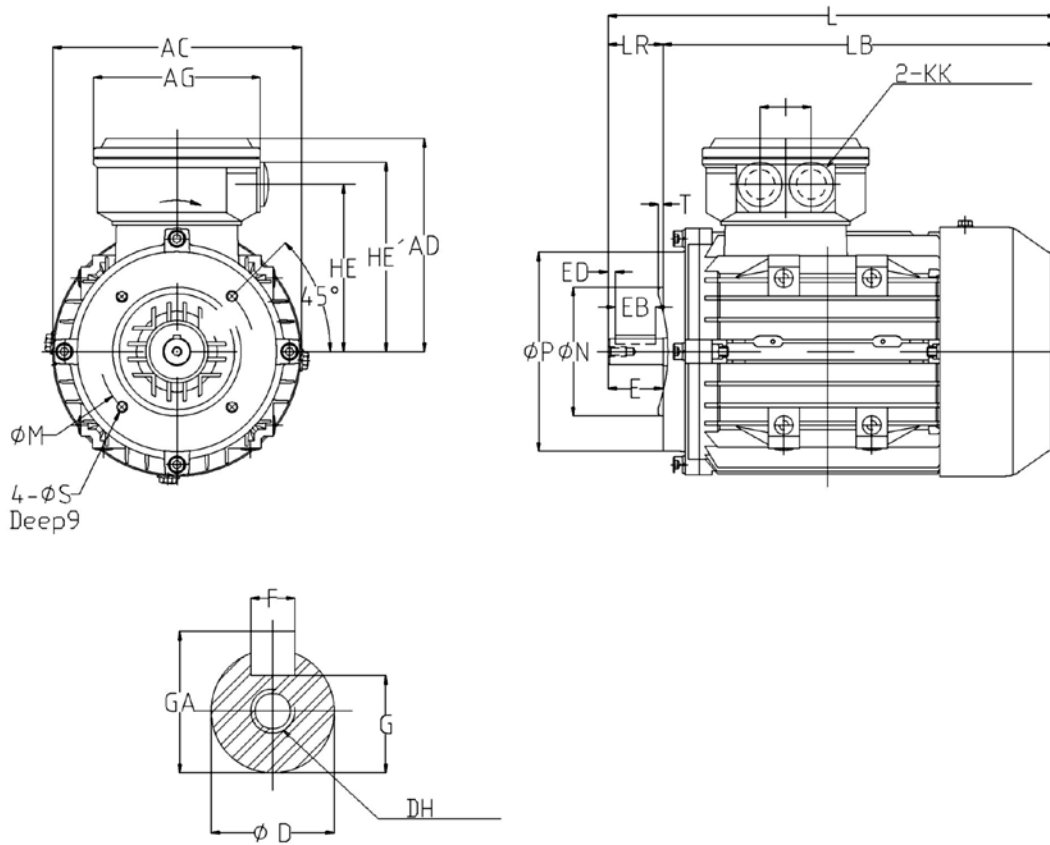

Figure 7-3: Outline drawing of aluminium design, face version, mounting B14, frame size 63 – 160 (sample)

Frame size	Outline drawing of aluminium design, face version, mounting B14, frame size 63 – 160, dimensions in [mm]													
	AC	AD	KK	LA	LB	LR	M	N	P	S	T	I	L	
63	S			1 M20 x 1.5 +										
	M	120	108		9	197,5	23	75	60	90	M5	3	28	220,5
	L													
71	S			1 M16 x 1.5 +										
	M	136	116		10	215	30	85	70	105	M6	3,5	28	245
	L													
80	S			2 M25 x 1.5 +										
	M	159	129		10	274	40	100	80	120	M6	3,5	28	314
	L													
90	S	176	139	1 M20 x 1.5 +										
	M				11	293	50	115	95	140	M8	3,5	38	343
	L	176	139		11	318	50	115	95	140	M8	3,5	38	368
100	S			2 M32 x 1.5 +										
	M				14	344	60	130	110	160	M8	4	38	404
	L	198	149											
112	S			1 M20 x 1.5 +										
	M	220	167		14	355	60	130	110	160	M8	4	40	415
	L													
132	S	258	186		15,5	382	80	165	130	200	M10	4	40	462
	M	258	186		15,5	420	80	165	130	200	M10	4	40	500
	L													
160	S			2 x M40 x 1.5 +										
	M	314	232		16	533	110	210	180	250	M12	5	56	643
	L	314	232		16	533	110	210	180	250	M12	5	56	643

Frame size	Shaft extension								Bearings			
	D	E	ED	EF	F	G	GA	DH	at DE	at NDE	Figure	
63	S							M4				
	M	11 j6	23	16	4	4	8,5	12,5	x	6201ZZC3	6201ZZC3	7-3
	L								8			
71	S								M5			
	M	14 j6	30	22	4	5	11	16	x	6202ZZC3	6202ZZC3	7-3
	L								10			
80	S								M6			
	M	19 j6	40	32	4	6	15,5	21,5	x	6204ZZC3	6204ZZC3	7-3
	L								12			
90	S	24 j6	50	40	5	8	20	27	M8	6205ZZC3	6205ZZC3	7-3
	M								x	6205ZZC3	6205ZZC3	7-3
	L	24 j6	50	40	5	8	20	27	16			
100	S								M10			
	M								x			
	L	28 j6	60	50	5	8	24	31	20	6206ZZC3	6305ZZC3	7-3
112	S								M10			
	M	28 j6	60	50	5	8	24	31	x	6306ZZC3	6306ZZC3	7-3
	L								20			
132	S	38 k6	80	70	5	10	33	41	M12	6308ZZC3	6308ZZC3	7-3
	M	38 k6	80	70	5	10	33	41	x	6308ZZC3	6308ZZC3	7-3
	L								24			
160	S								M16			
	M	42 k6	110	100	5	12	37	45	x	6309ZZC3	6309ZZC3	7-3
	L	42 k6	110	100	5	12	37	45	32	6309ZZC3	6309ZZC3	7-3

7.2 Cast iron design

7.2.1 Cast iron design; feet version (B3)

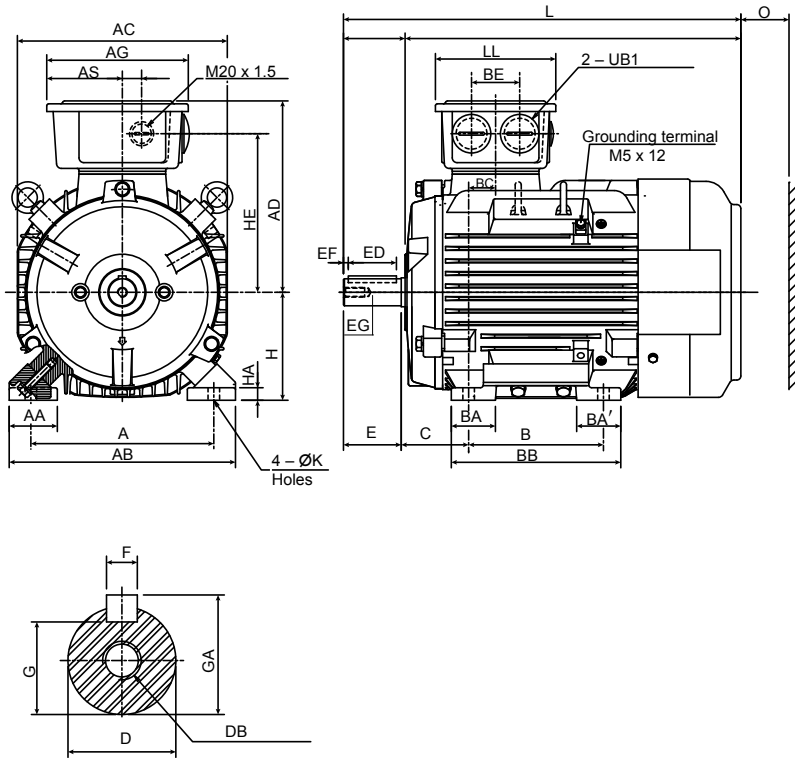

Figure 7-4: Outline drawing of cast iron design, feet version, mounting B3; frame size 80 – 112

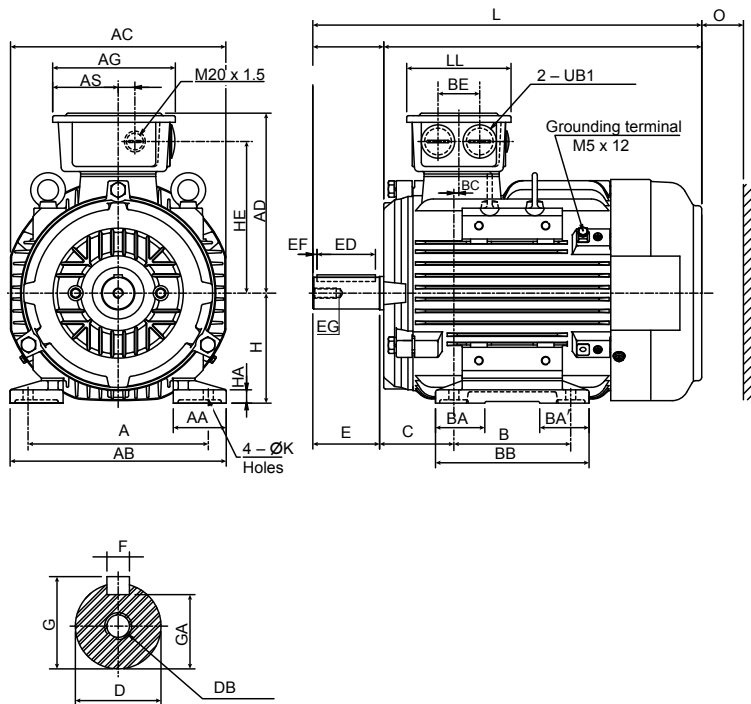

Figure 7-5: Outline drawing of cast iron design, feet version, mounting B3; frame size 132

Frame size		Outline drawing of cast iron design, feet version, mounting B3; frame size 80M – 112M, dimensions in [mm]																		
		A	AA	AB	AC	AD	AG	AS	B	B'	BA	BA'	BB	BE	BC	C	H	HA	HE	HE'
80	S																			
	M	125	35	161	156	161	115	57,5	100		35,5	35,5	130	40	18,5	50	80	10	123,5	—
	L																			—
90	S	140	40	180	176	171	115	57,5	100		33,0	33,0	125	40	36	56	90	10	133,5	—
	M																			—
	L	140	40	180	176	171	115	57,5					150	40	36	56	90	10	133,5	—
100	S																			
	M																			
	L	160	40	200	196	191	147	68,5	140		43,5	43,5	176	46	21	63	100	12	157	—
112	S																			
	M	190	50	235	218	198,5	147	68,5	140		45,5	45,5	176	46	28	70	112	13	164,5	—
	L																			
132	S	216	63,5	259	258	216	147	68,5	140		59	59	184	46	6	89	132	16	182	
	M	216	63,5	259	258	216	147	68,5	178		59	97	222	46	6	89	132	16	182	
	L																			

*) = 4-, 6- and 8-pole version

Frame size		Shaft extension														Bearings			
		K	L	LL	O	UB1	UB2	D	E	EB	ED	EG	F	G	GA	DB	at DE	at NDE	Fig.
80	S																		
	M	10	293,0	115	40	M25 x1,5		19	40		32	16	6	15,5	21,5	M6	6204ZZC3	6204ZZC3	7-4
	L																		
90	S	10	344,5	115	40	M25 x1,5		24	50		40	19	8	20,0	27,0	M8	6205ZZC3	6205ZZC3	7-4
	M																		
	L	10	369,5	115	40	M25 x1,5		24	50		40	19	8	20,0	27,0	M8	6205ZZC3	6205ZZC3	7-4
100	S																		
	M																		
	L	12	392,0	125	50	M32 x1,5		28	60		50	22	8	24,0	31,0	M10	6206ZZC3	6206ZZC3	7-4
112	S																		
	M	12	412,5	125	50	M32 x1,5		28	60		50	22	8	24,0	31,0	M10	6306ZZC3	6306ZZC3	7-4
	L																		
132	S	12	466,0	125	50	M32 x1,5		38	80		70	28	10	33	41	M12	6308ZZ3	6306ZZC3	7-5
	M	12	504	125	50	M32 x1,5		38	80		70	28	10	33	41	M12	6308ZZ3	6306ZZC3	7-5
	L																		

*) = 4-, 6- and 8-pole version

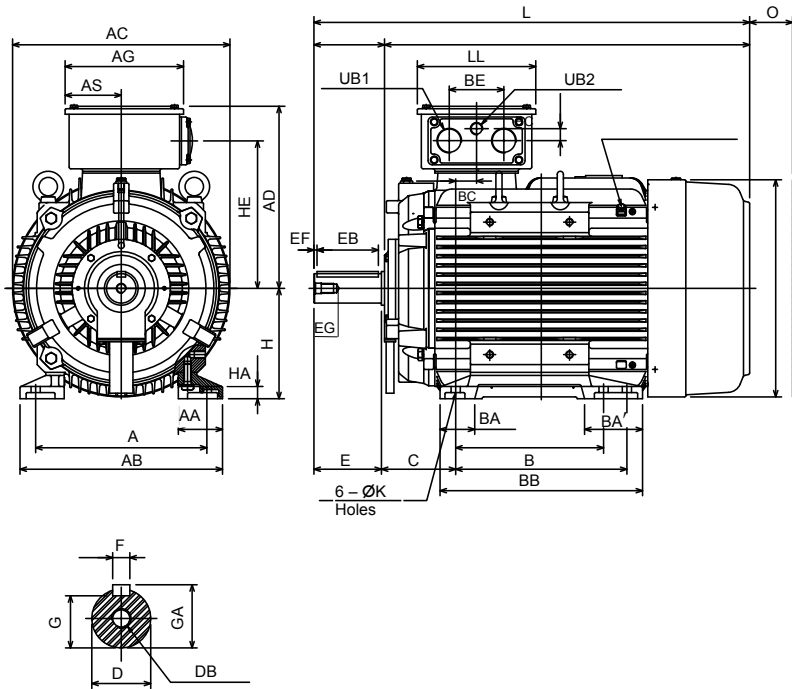

Figure 7-6: Outline drawing of cast iron design, feet version, mounting B3; frame size 160 – 180

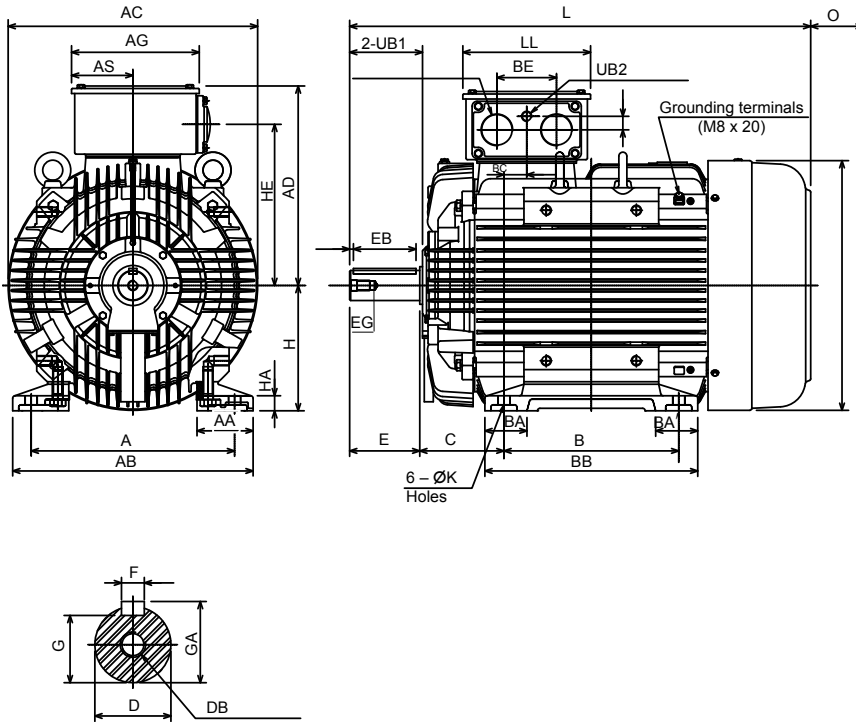

Figure 7-7: Outline drawing of cast iron design, feet version, mounting B3; frame size 200 – 250 (sample)

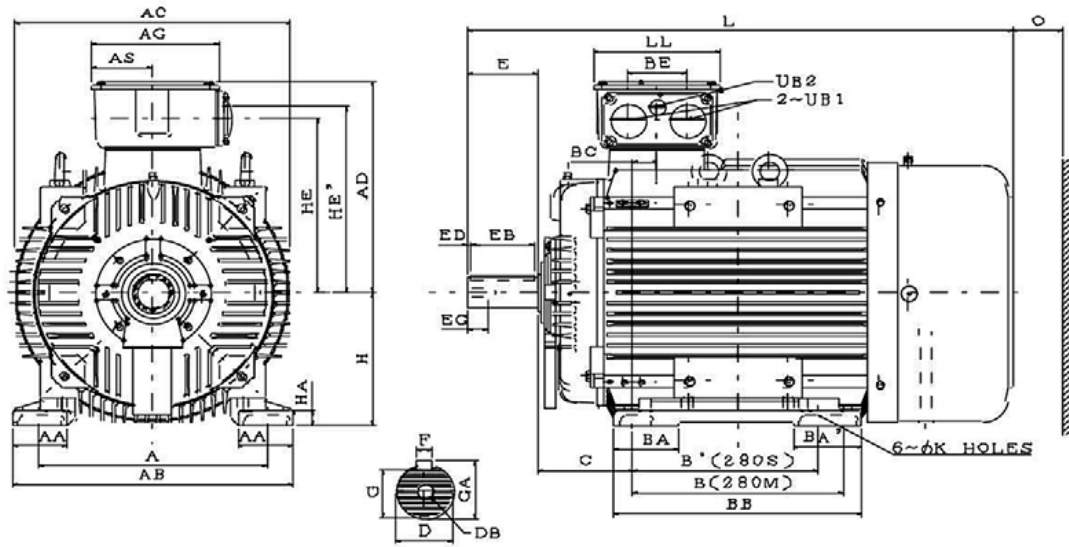

Figure 7-8: Outline drawing of cast iron design, feet version, mounting B3; frame size 280

Frame size		Outline drawing of cast iron design, feet version, mounting B3; frame size 160 – 280, dimensions in [mm]																		
		A	AA	AB	AC	AD	AG	AS	B	B'	BA	BA'	BB	BE	BC	C	H	HA	HE	HE'
160	S																			
	M	254	71	300	317	271	193	91,5	210	—	46	46	256	77	38	108	160	18	215	—
	L	254	71	300	317	271	193	91,5	254	210	46	90	300	77	38	108	160	18	215	—
180	S																			
	M	279	72	330	354	297	193	91,5	241	—	57	57	292	77	34	121	180	20	241	—
	L	279	72	330	354	297	193	91,5	279	241	57	95	330	77	34	121	180	20	241	—
200	S																			
	M																			
	L	318	88	378	398	330	231	110,5	305	—	70	70	365	95	53	133	200	24	262	—
225	S	356	94	416	449	356	231	110,5	286	—	70	70	350	95	30,5	149	225	28	288	—
	M	356	94	416	449	356	231	110,5	311	286	70	95	375	95	30,5	149	225	28	288	—
	M*	356	94	416	449	356	231	110,5	311	286	70	95	375	95	30,5	149	225	28	288	—
	L																			
250	S																			
	M	406	112	480	498	398	255	122,5	349	—	84	84	425	111	45,5	168	250	30	322	—
	M*	406	112	480	498	398	255	122,5	349	—	84	84	425	111	45,5	168	250	30	322	—
	L																			
280	S	457	110	560	550	446	255	122,5	—	368	130	130	445	119	48	190	280	32	367	394
	S*	457	110	560	550	446	255	122,5	—	368	130	130	445	119	48	190	280	32	367	394
	S**	457	110	560	550	446	255	122,5	—	368	130	130	445	119	48	190	280	32	367	394
280	M	457	110	560	550	446	255	122,5	419	—	130	137	495	119	48	190	280	32	367	394
	M*	457	110	560	550	446	255	122,5	419	—	130	137	495	119	48	190	280	32	367	394
	M**	457	110	560	550	446	255	122,5	419	—	130	137	495	119	48	190	280	32	367	394

*) = 4-, 6- and 8-pole version
 **) = 4-, 6-, 8-pole version

Frame size		Overall dimensions					Shaft extension										Bearings		
		K	L	LL	O	UB1	UB2	D	E	EB	ED	EG	F	G	GA	DB	at DE	at NDE	Fig.
160	S																		
	M	14,5	608	193	60	M40 x 1,5	M20 x 1,5	42 k6	110	100	5,0	32	12	37,0	45,0	M16	6309ZZC3	6307ZZC3	7-6
	L	14,5	652	193	60	M40 x 1,5	M20 x 1,5	42 k6	110	100	5,0	32	12	37,0	45,0	M16	6309ZZC3	6307ZZC3	7-6
180	S																		
	M	14,5	672	193	70	M40 x 1,5	M20 x 1,5	48 k6	110	100	5,0	32	14	42,5	51,5	M16	6311C3	6310C3	7-6
	L	14,5	710	193	70	M40 x 1,5	M20 x 1,5	48 k6	110	100	5,0	32	14	42,5	51,5	M16	6311C3	6310C3	7-6
200	S																		
	M																		
	L	18,5	770	231	80			55m6	110	100	5,0	40	16	49,0	59,0	M20	6312C3	6212C3	7-7
225	S	18,5	816	231	90			60m6	140	125	7,5	40	18	53,0	64,0	M20	6313C3	6213C3	7-7
	M	18,5	811	231	90	M50 x 1,5	M20 x 1,5	55m6	110	100	5,0	40	16	49,0	59,0	M20	6312C3	6212C3	7-7
	M*	18,5	841	231	90	M50 x 1,5	M20 x 1,5	60m6	140	125	7,5	40	18	53,0	64,0	M20	6313C3	6213C3	7-7
	L																		
250	S																		
	M	24,0	921	255	105	M63 x 1,5	M20 x 1,5	60m6	140	125	7,5	40	18	53,0	64,0	M20	6313C3	6313C3	7-7
	M*	24,0	921	255	105	M63 x 1,5	M20 x 1,5	65m6	140	125	7,5	40	18	58,0	69,0	M20	6315C3	6313C3	7-7
280	S																		
	M	24,0	1037	255	—			65m6	140	125	7,5	42	18	58,0	69,0	M20	6316C3	6314C3	7-8
	S*	24,0	1037	255	—			75m6	140	125	7,5	42	20	67,5	79,5	M20	6318C3	6316C3	7-8
	S**	24,0	1037	255	—	M63 x 1,5	M20 x 1,5	75m6	140	125	7,5	42	20	67,5	79,5	M20	NU318	6316C3	7-8
280	M	24,0	1087,5	255	—			65m6	140	125	7,5	42	18	58,0	69,0	M20	6316C3	6314C3	7-8
	M*	24,0	1087,5	255	—			75m6	140	125	7,5	42	20	67,5	79,5	M20	6318C3	6316C3	7-8
	M**	24,0	1087,5	255	—			75m6	140	125	7,5	42	20	67,5	79,5	M20	NU318	6316C3	7-8

*) = 4-, 6- and 8-pole version
 **) = 4-, 6-, 8-pole version

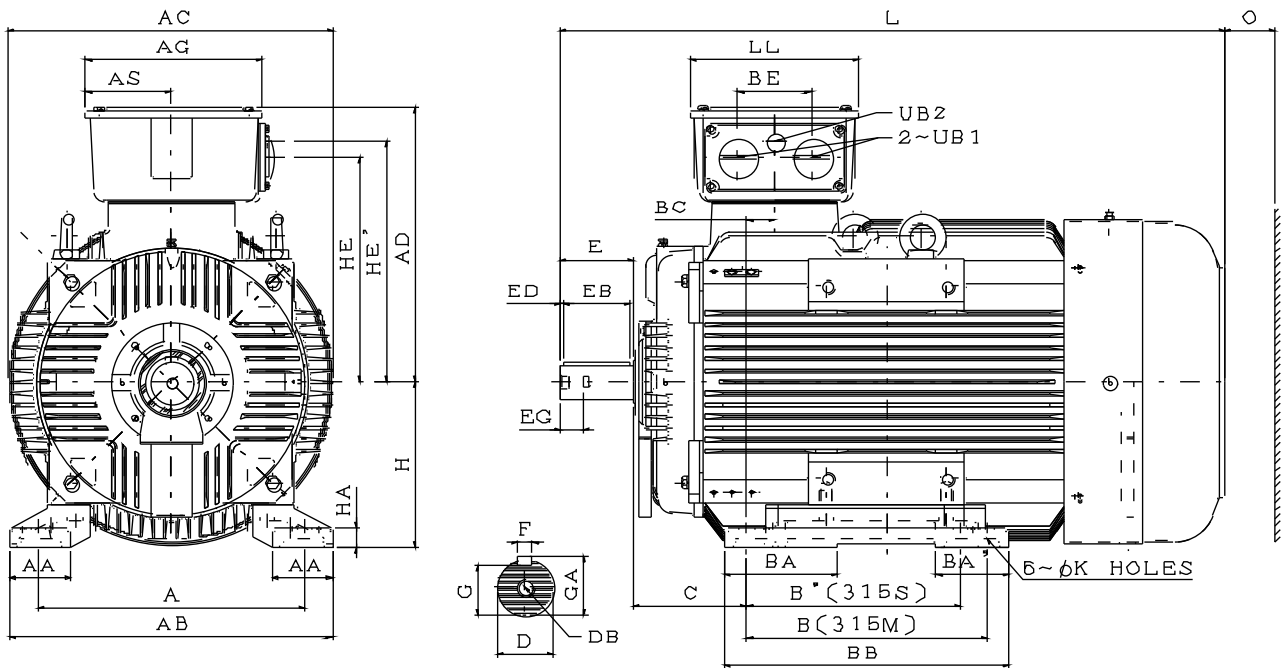

Figure 7-9: Outline drawing of cast iron design, feet version, mounting B3; frame size 315S – 315M (sample)

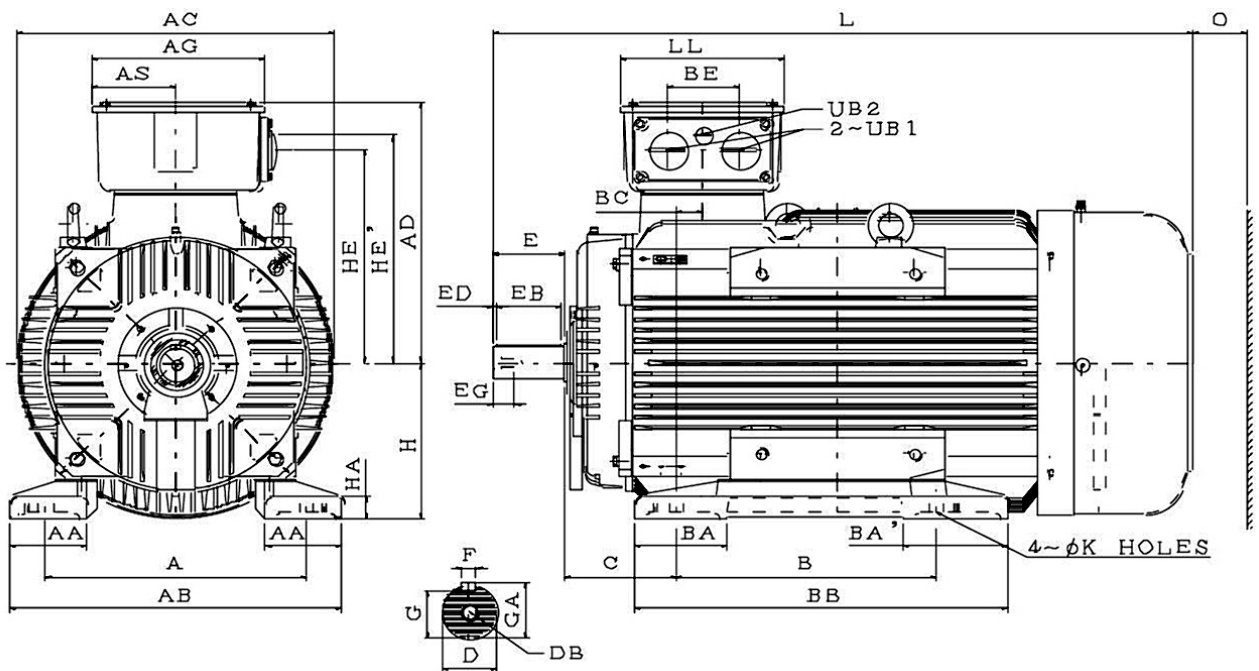

Figure 7-10: Outline drawing of cast iron design, feet version, mounting B3; frame size 315L

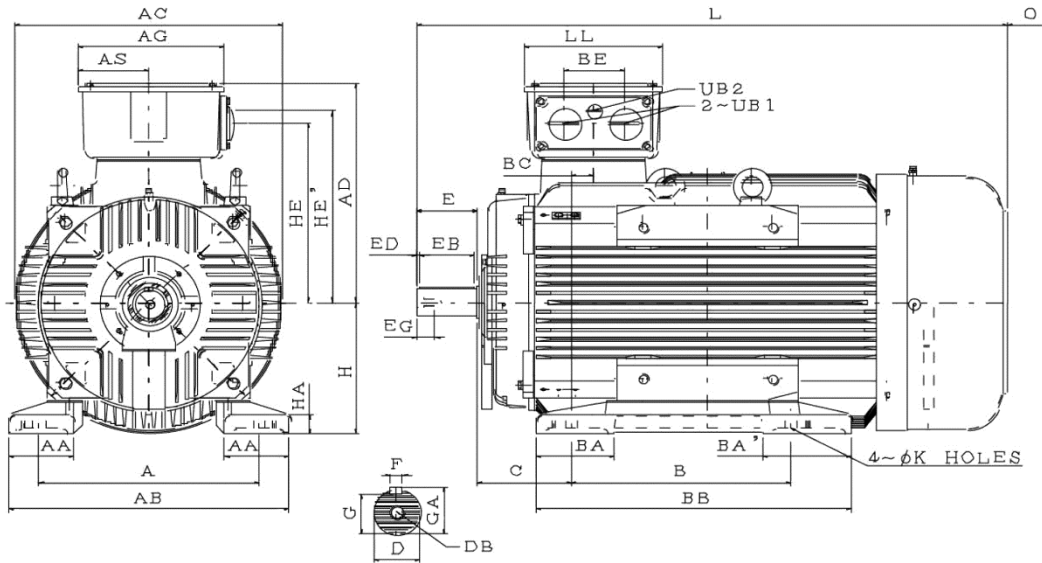

Figure 7-11: Outline drawing of cast iron design, feet version, mounting B3; frame size 315D

Frame size		Outline drawing of cast iron design, feet version, mounting B3; frame size 315S – 315M, 315L, 315D, dimensions in [mm]																		
		A	AA	AB	AC	AD	AG	AS	B	B'	BA	BA'	BB	BE	BC	C	H	HA	HE	HE'
315	S	508	115	615	620	527	336	163	406		150	150	508	140	53	216	315	35	430	460
	S*	508	115	615	620	527	336	163	406		150	150	508	140	53	216	315	35	430	460
	S**	508	115	615	620	527	336	163	406		150	150	508	140	53	216	315	35	430	460
315	M	508	115	615	620	527	336	163	457	—	213	137	540	140	53	216	315	35	430	460
	M*	508	115	615	620	527	336	163	457	—	213	137	540	140	53	216	315	35	430	460
	M**	508	115	615	620	527	336	163	457	—	213	137	540	140	53	216	315	35	430	460
315	L	508	150	650	620	527	336	163	508	—	180	205	730	140	53	216	315	45	430	460
	L*	508	150	650	620	527	336	163	508	—	180	205	730	140	53	216	315	45	430	460
	L**	508	150	650	620	527	336	163	508	—	180	205	730	140	53	216	315	45	430	460
315	D	508	150	650	682	590	412	189	900	—	255	255	1080	180	68	216	315	45	485	515
	D*	508	150	650	682	590	412	189	900	—	255	255	1080	180	68	216	315	45	485	515
	D**	508	150	650	682	590	412	189	900	—	255	255	1080	180	68	216	315	45	485	515

*) = 4-, 6- and 8-pole version
 **) = 4-, 6-, 8-pole version; 315D frame with optional roller bearing

Frame size	Overall dimensions						Shaft extension										Bearings		
	K	L	LL	O	UB1	UB2	D	E	EB	ED	EG	F	G	GA	DB	at DE	at NDE	Fig.	
315	S	28	1216	322	—	M63 x 1,5	M20 x 1,5	65m6	140	125	7,5	42	18	58	69	M20	6316C3	6314C3	7-9
	S*	28	1246	322	—			80m6	170	160	5	42	22	71	85	M20	6320C3	6316C3	7-9
	S**	28	1246	322	—			80m6	170	160	5	42	22	71	85	M20	NU320	6316C3	7-9
315	M	28	1266	322	—	M63 x 1,5	M20 x 1,5	65m6	140	125	7,5	42	18	58	69	M20	6316C3	6314C3	7-9
	M*	28	1296	322	—			80m6	170	160	5	42	22	71	85	M20	6320C3	6316C3	7-9
	M**	28	1296	322	—			80m6	170	160	5	42	22	71	85	M20	NU320	6316C3	7-9
315	L	28	1366	322	—	M63 x 1,5	M20 x 1,5	65m6	140	125	7,5	42	18	58	69	M20	6316C3	6314C3	7-10
	L*	28	1396	322	—			80m6	170	160	5	42	22	71	85	M20	6320C3	6316C3	7-10
	L**	28	1396	322	—			80m6	170	160	5	42	22	71	85	M20	NU320	6316C3	7-10
315	D	28	1674	372	—	M63 x 1,5	M20 x 1,5	65m6	140	125	7,5	42	18	58	69	M20	6316C3	6316C3	7-11
	D*	28	1704	372	—			85m6	170	160	5	42	22	76	90	M20	6322C3	6322C3	7-11
	D**	28	1704	372	—			95m6	170	160	5	50	25	86	100	M24	NU322	6322C3	7-11

*) = 4-, 6- and 8-pole version
 **) = 4-, 6-, 8-pole version; 315D frame with optional roller bearing

7.2.2 Cast iron design; flange version (B5)

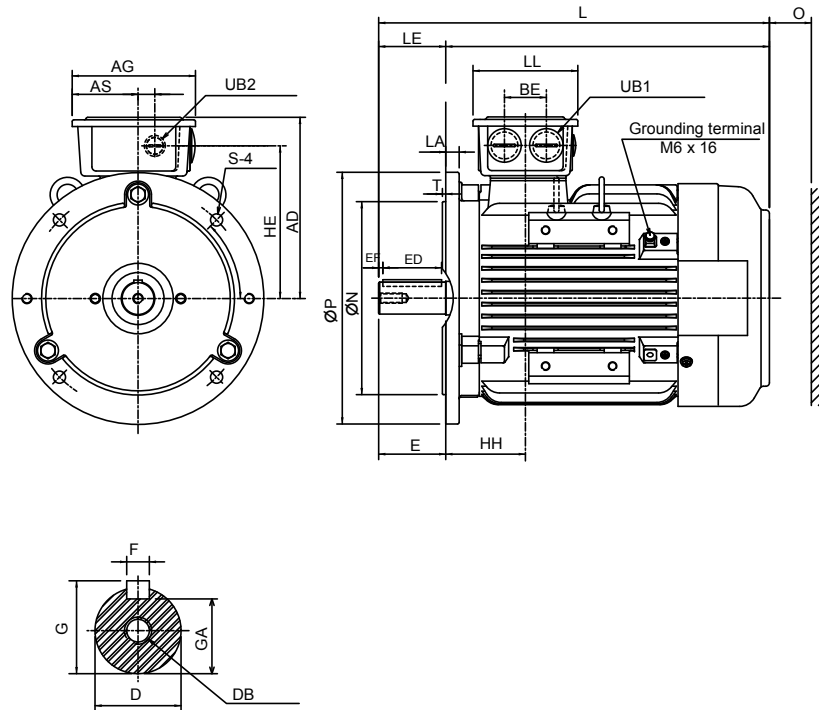

Figure 7-12: Outline drawing of cast iron design, flange version, mounting B5, frame size 160

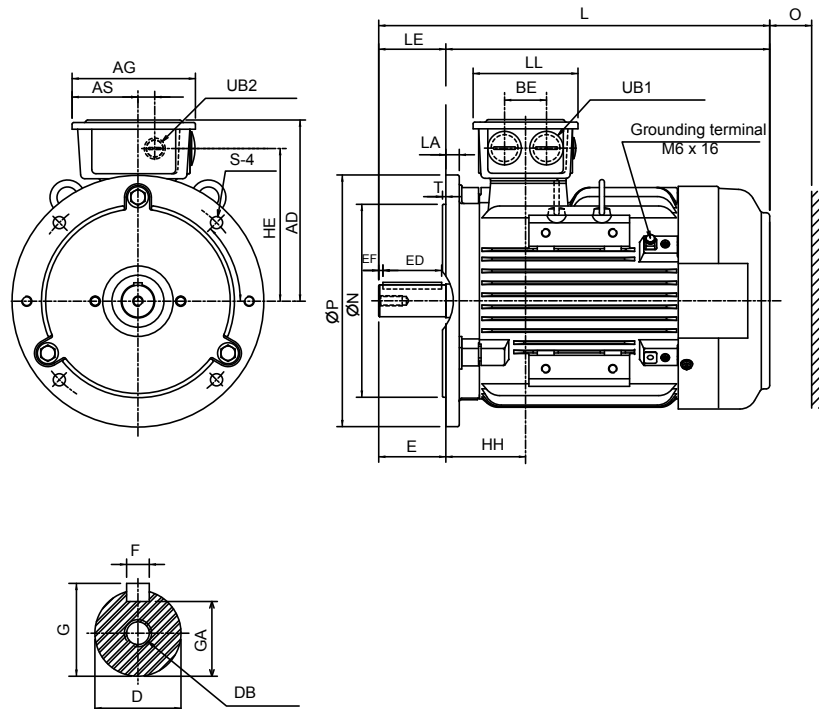

Figure 7-13: Outline drawing of cast iron design, flange version, mounting B5, frame size 160 – 180

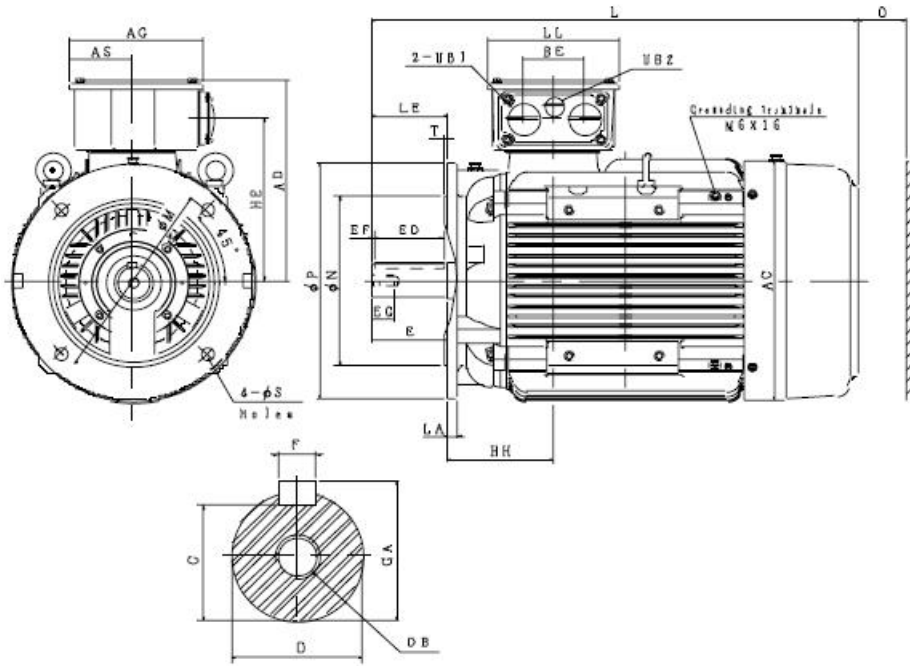

Figure 7-14: Outline drawing of cast iron design, flange version, mounting B5, frame size 200

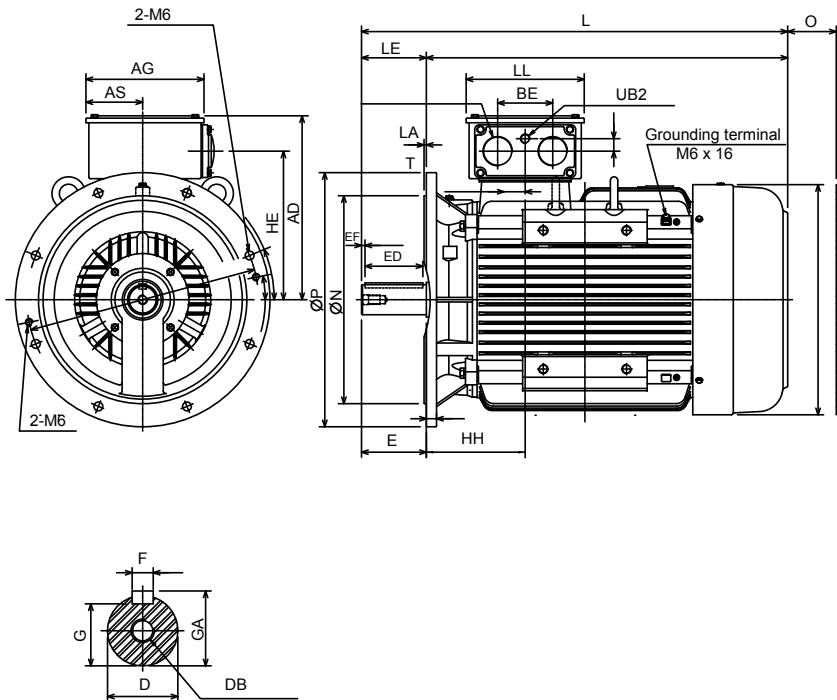

Figure 7-15: Outline drawing of cast iron design, flange version, mounting B5, frame size 225 – 250

Frame size		Outline drawing of cast iron design, flange version, mounting B5, frame size 80 – 250, dimensions in [mm]															
		AC	AD	AG	AS	BE	HH	HE	HE'	LA	LE	M	N	P	S	T	
80	S																
	M	156	161	125	67,5	40	68,5	123,5		12	40	165	130	200	12	3,5	
	L																
90	S	176	171	125	67,5	40	92	133,5		12	50	165	130	200	12	3,5	
	M																
	L	176	171	125	67,5	40	92	133,5		12	50	165	130	200	12	3,5	
100	S																
	M																
	L	196	191	147	78,5	50	84	157		16	60	215	180	250	14,5	4	
112	S																
	M	218	198,5	147	78,5	50	98	164,5		15	60	215	180	250	14,5	4	
	L																
132	S	258	216	147	78,5	50	95	182		16	80	265	230	300	14,5	4	
	M	258	216	147	78,5	50	95	182		16	80	265	230	300	14,5	4	
	L																
160	S																
	M	317	271	193	91,5	89	146	215		15	110	300	250j6	350	18,5	5	
	L	317	271	193	91,5	89	146	215		15	110	300	250j6	350	18,5	5	
180	S																
	M	354	297	193	91,5	89	155	241		15	110	300	250j6	350	18,5	5	
	L	354	297	193	91,5	89	155	241		15	110	300	250j6	350	18,5	5	
200	S																
	M																
	L	398	330	231	110,5	106	193	262		17	110	350	300j6	400	18,5	5	
225	S	449	356	231	110,5	106	179,5	288		20	140	400	350j6	450	18,5	5	
	M	449	356	231	110,5	106	179,5	288		20	110	400	350j6	450	18,5	5	
	M*	449	356	231	110,5	106	179,5	288		20	140	400	350j6	450	18,5	5	
250	S																
	M	498	398	255	122,5	119	213,5	322		22	140	500	450j6	550	18,5	5	
	M*	498	398	255	122,5	119	213,5	322		22	140	500	450j6	550	18,5	5	

*) = 4-, 6- and 8-pole version

Frame size		Overall dimensions					Shaft extension								Bearings				
		L	LL	O	UB1	UB2	D	E	EF	ED	EG	F	G	GA	DB	at DE	at NDE	Fig.	
80	S																		
	M	293	115	40	M25 x 1,5	M20 x 1,5	19	40	4		16	6	15,5	21,5	M6	6204ZZC3	6204ZZC3		
	L																		
S	344,5	115	40	24			50	5		19	8	20	27	M8	6207ZZC3	6205ZZC3			
90	M																		
	L	369,5	115	40	24	50	5		19	8	20	27	M8	6205ZZC3	6205ZZC3				
	S																		
100	M																		
	L	392	125	50	28	60	5		22	8	24	31	M10	6206ZZC3	6206ZZC3				
	S																		
112	M	412,5	125	50	M32 x 1,5	M20 x 1,5	28	60	5		22	8	24	31	M10	6306ZZC3	6306ZZC3		
	L																		
	S	466	125	50			38	80	5		28	10	33	41	M12	6308ZZC3	6306ZZC3		
132	M	504	125	50	38	80	5		28	10	33	41	M12	6308ZZC3	6306ZZC3				
	L																		
	S																		
160	M	608	193	60	M40 x 1,5	M20 x 1,5	42k6	110	5	100	32	12	37	45	M16	6309ZZC3	6307ZZC3	7-12	
	L	652	193	60			42k6	110	5	100	32	12	37	45	M16	6309ZZC3	6307ZZC3	7-12	
	S																		
180	M	672	193	70	48k6	110	5	100	32	14	42,5	51,5	M16	6311C3	6310C3	7-13			
	L	710	193	70	48k6	110	5	100	32	14	42,5	51,5	M16	6311C3	6310C3	7-13			
	S																		
200	M				M50 x 1,5	M20 x 1,5													
	L	770	231	80			55m6	110	5	100	42	16	49	59	M20	6312C3	6212C3	7-14	
	S	816	231	90			60m6	140	7,5	125	42	18	53	64	M20	6313C3	6213C3	7-15	
225	M	811	231	90	M50 x 1,5	M20 x 1,5	55m6	110	5	100	42	16	49	59	M20	6312C3	6212C3	7-15	
	M*	841	231	90			60m6	140	7,5	125	42	18	53	64	M20	6313C3	6213C3	7-15	
	S																		
250	M	921	255	105	M63 x 1,5	M20 x 1,5	60m6	140	7,5	125	42	18	53	64	M20	6313C3	6313C3	7-15	
	M*	921	255	105			65m6	140	7,5	125	42	18	58	69	M20	6315C3	6313C3	7-15	
	S																		

*) = 4-, 6- and 8-pole version

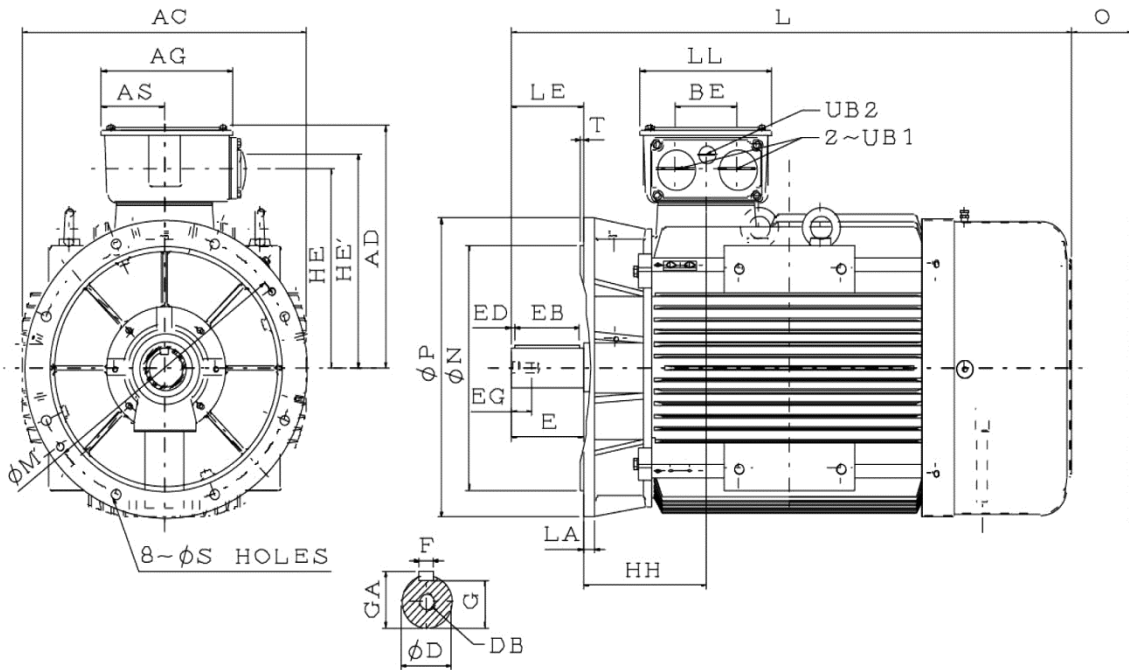

Figure 7-16: Outline drawing of cast iron design, flange version, mounting B5, frame size 280

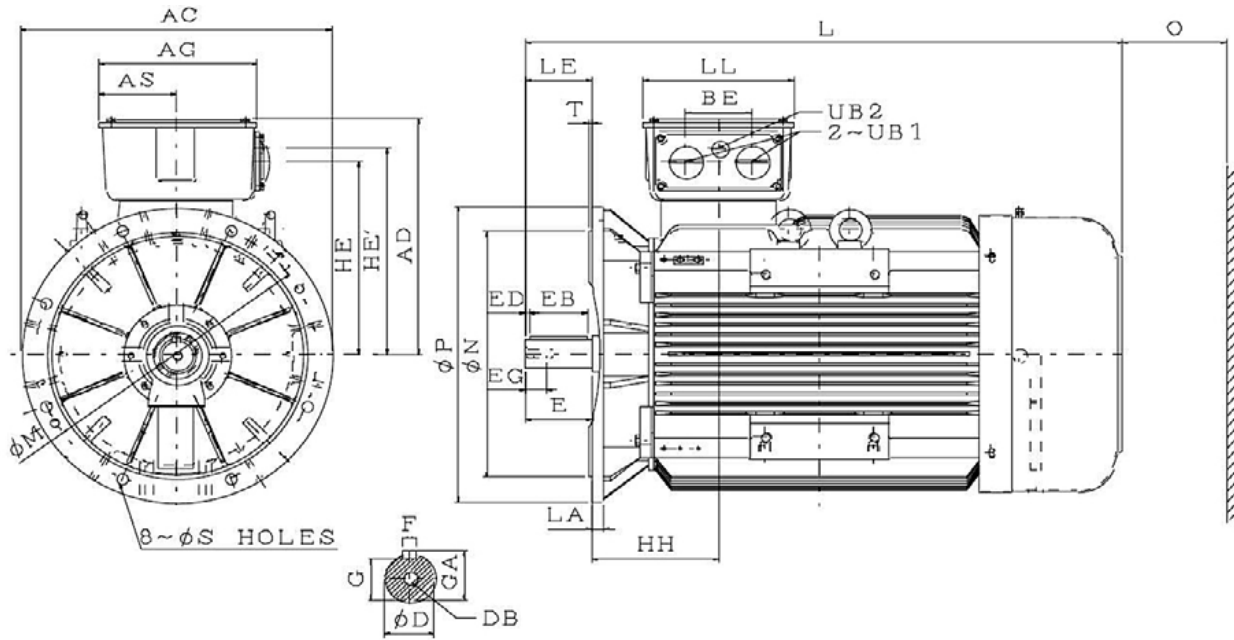

Figure 7-17: Outline drawing of cast iron design, flange version, mounting B5, frame size 315

Frame size		Outline dimensions of cast iron design, flange version horizontal, mounting B5, frame size 280 – 315, dimensions in [mm]																	
		Overall dimensions												Flange dimensions					
		AC	AD	AG	AS	BE	HH	HE	HE'	LA	LE	M	N	P	S	T			
280	S	550	446	255	122,5	119	238	367	394	22	140	500	450	550	18,5	5			
	S*	550	446	255	122,5	119	238	367	394	22	140	500	450	550	18,5	5			
	S**	550	446	255	122,5	119	238	367	394	22	140	500	450	550	18,5	5			
280	M	550	446	255	122,5	119	238	367	394	22	140	500	450	550	18,5	5			
	M*	550	446	255	122,5	119	238	367	394	22	140	500	450	550	18,5	5			
	M**	550	446	255	122,5	119	238	367	394	22	140	500	450	550	18,5	5			
315	S	660	527	336	163	140	269	430	460	25	140	600	550	660	24	6			
	S*	660	527	336	163	140	269	430	460	25	170	600	550	660	24	6			
	S**	660	527	336	163	140	269	430	460	25	170	600	550	660	24	6			
315	M	660	527	336	163	140	269	430	460	25	140	600	550	660	24	6			
	M*	660	527	336	163	140	269	430	460	25	170	600	550	660	24	6			
	M**	660	527	336	163	140	269	430	460	25	170	600	550	660	24	6			

*) = 4-, 6- and 8-pole version
 **) = 4-, 6-, 8-pole version; 315D frame with optional roller bearing

Frame size		Overall dimensions					Shaft extension										Bearings		
		L	LL	O	UB1	UB2	D	E	EB	ED	EG	F	G	GA	DB	at DE	at NDE	Fig.	
280	S	1037	255	—	M63 x 1,5	M20 x 1,5	65m6	140	125	7,5	42	18	58,0	69,0	M20	6316C3	6314C3	7-16	
	S*	1037	255	—			75m6	140	125	7,5	42	20	67,5	79,5	M20	6318C3	6316C3	7-16	
	S**	1037	255	—			75m6	140	125	7,5	42	20	67,5	79,5	M20	NU318	6316C3	7-16	
280	M	1087,5	255	—	M63 x 1,5	M20 x 1,5	65m6	140	125	7,5	42	18	58,0	69,0	M20	6316C3	6314C3	7-16	
	M*	1087,5	255	—			75m6	140	125	7,5	42	20	67,5	79,5	M20	6318C3	6316C3	7-16	
	M**	1087,5	255	—			75m6	140	125	7,5	42	20	67,5	79,5	M20	NU318	6316C3	7-16	
315	S	1216	322	—	M63 x 1,5	M20 x 1,5	65m6	140	125	7,5	42	18	58	69	M20	6316C3	6314C3	7-17	
	S*	1246	322	—			80m6	170	160	5	42	22	71	85	M20	6320C3	6316C3	7-17	
	S**	1246	322	—			80m6	170	160	5	42	22	71	85	M20	NU320	6316C3	7-17	
315	M	1266	322	—	M63 x 1,5	M20 x 1,5	65m6	140	125	7,5	42	18	58	69	M20	6316C3	6314C3	7-17	
	M*	1296	322	—			80m6	170	160	5	42	22	71	85	M20	6320C3	6316C3	7-17	
	M**	1296	322	—			80m6	170	160	5	42	22	71	85	M20	NU320	6316C3	7-17	

*) = 4-, 6- and 8-pole version
 **) = 4-, 6-, 8-pole version; 315D frame with optional roller bearing

7.2.3 Cast iron design; version with feet and flange (B35)

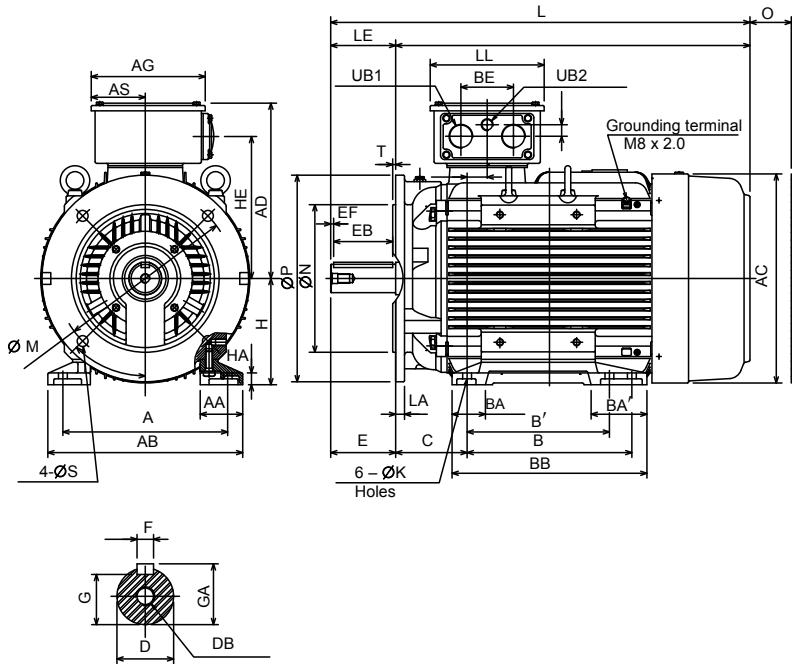

Figure 7-18: Outline drawing of cast iron design, mounting B35; frame size 160 – 180

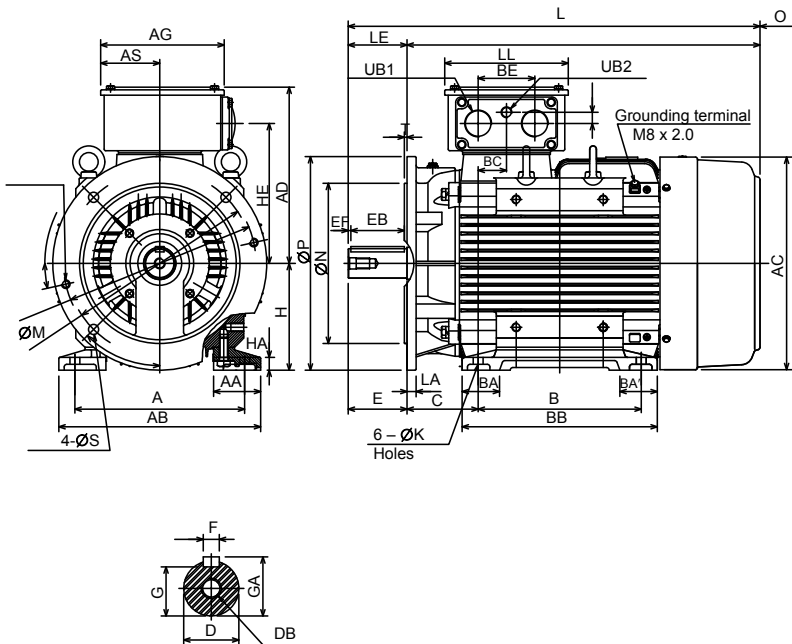

Figure 7-19: Outline drawing of cast iron design, mounting B35; frame size 200 – 250

Outline dimensions of cast iron design, flange/feet version, mounting B35, frame size 80 – 250, dimensions in [mm]																			
Frame size	A	AA	AB	AC	AD	AG	AS	B	B'	BA	BA'	BB	BE	BC	C	H	HA	HE	HE'
80	S																		
	M	125	35	156	156	161	125	67,5	100		33,5	33,5	130	40	18,5	50	80	10	123,5
	L																		
90	S	140	40	180	176	171	125	67,5	100		33	33	125	40	36	56	90	10	133,5
	M																		
	L	140	40	180	176	171	125	67,5	125	100	33	33	125	40	36	56	90	10	133,5
100	S																		
	M																		
	L	160	40	200	196	191	147	78,5	140		43,5	43,5	176	50	21	63	100	12	157
112	S																		
	M	190	50	235	218	198,5	147	78,5	140		45,5	45,5	176	50	28	70	112	13	164,5
	L																		
132	S	216	63,5	259	258	216	147	78,5	140		59	59	184	50	6	89	132	16	182
	M	216	63,5	259	258	216	147	78,5	178	140	59	97	222	50	6	89	132	16	182
	L																		
160	S																		
	M	254	71	300	317	271	193	91,5	210	—	46	46	256	77	38	108	160	18	215
	L	254	71	300	317	271	193	91,5	254	210	46	90	300	77	38	108	160	18	215
180	S																		
	M	279	72	330	354	297	193	91,5	241	—	57	57	292	77	34	121	180	20	241
	L	279	72	330	354	297	193	91,5	279	241	57	95	330	77	34	121	180	20	241
200	S																		
	M																		
	L	318	88	378	398	330	231	110,5	305	—	70	70	365	106	53	133	200	24	262
225	S	356	94	416	449	356	231	110,5	286	—	70	70	350	106	30,5	149	225	28	288
	M	356	94	416	449	356	231	110,5	311	286	70	95	375	106	30,5	149	225	28	288
	L																		
250	S																		
	M	406	112	480	498	398	255	122,5	349	—	84	84	425	119	45,5	168	250	30	322
	L																		

*) = 4-, 6- and 8-pole version

Frame size		K	L	LL	O	UB1	UB2	Shaft extension								Bearings			Fig.			
								D	E	EB	ED	EG	F	G	GA	DB	at DE	at NDE				
80	S																					
	M	10	293	115	40	M20 x 1,5	M20 x 1,5	19	40	32	4	16	6	15,5	21,5	M6	6204ZZC3	6204ZZC3				
	L																					
S	10	344,5	115	40	24			50	40	5	19	8	20	27	M8	6205ZZC3	6205ZZC3	7-18				
90	M																					
	L	10	369,5	115	40			24	50	40	5	19	8	20	27	M8	6205ZZC3	6205ZZC3	7-18			
	S																					
100	M					M32 x 1,5	M20 x 1,5															
	L	12	392	125	50			28	60	50	5	22	8	24	31	M10	6206ZZC3	6206ZZC3	7-18			
	S																					
112	M	12	412,5	125	50			28	60	50	5	22	8	24	31	M10	6306ZZC3	6306ZZC3	7-18			
	L																					
	S	12	466	125	50			38	80	70	5	28	10	33	41	M12	6308ZZC3	6308ZZC3	7-18			
132	M					M31 x 1,5	M20 x 1,5															
	L	12	504	125	50			38	80	70	5	28	10	33	41	M12	6308ZZC3	6308ZZC3	7-18			
	S																					
160	M	14,5	608	193	60	M40 x 1,5	M20 x 1,5	42k6	110	100	5,0	32	12	37,0	45,0	M16	6309ZZC3	6307ZZC3	7-18			
	L	14,5	652	193	60			42k6	110	100	5,0	32	12	37,0	45,0	M16	6309ZZC3	6307ZZC3	7-18			
	S																					
180	M	14,5	672	193	70	M40 x 1,5	M20 x 1,5	48k6	110	100	5,0	32	14	42,5	51,5	M16	6311C3	6310C3	7-18			
	L	14,5	710	193	70			48k6	110	100	5,0	32	14	42,5	51,5	M16	6311C3	6310C3	7-18			
	S																					
200	M					M50 x 1,5	M20 x 1,5															
	L	18,5	770	231	80			55m6	110	100	5,0	42	16	49,0	59,0	M20	6312C3	6212C3	7-19			
	S	18,5	816	231	90			60m6	140	125	7,5	42	18	53,0	64,0	M20	6313C3	6213C3	7-19			
225	M	18,5	841	231	90			60m6	140	125	7,5	42	18	53,0	64,0	M20	6313C3	6213C3	7-19			
	L																					
	S																					
250	M	24,0	921	255	105			65m6	140	125	7,5	42	18	58,0	69,0	M20	6315C3	6313C3	7-19			
	L																					
	S																					

*) = 4-, 6- and 8-pole versions

Frame size		Flange dimensions						
		LA	LE	M	N	P	S	T
80	M							
	L	12	40	100	80	120	6	3
90	S							
	M	10,33	50	115	95	140	8	3
100	L							
	M	10,33	50	115	95	140	8	3
112	S							
	M	9,84	60	130	110	160	8	3,5
	L							
132	S	9,84	60	130	110	160	8	3,5
	L	16	80	300	265	230	14,5	4

Frame size		Flange dimensions						
		LA	LE	M	N	P	S	T
160	M	15	—	300	250 j6	350	18,5	5
	L	15	—	300	250 j6	350	18,5	5
180	S							
	M	15	—	300	250 j6	350	18,5	5
200	L	15	—	300	250 j6	350	18,5	5
	M	17	—	350	300 j6	400	18,5	5
225	S	20	—	400	350 j6	450	18,5	5
	M	20	—	400	350 j6	450	18,5	5
	L							
250	S							
	M	22	—	500	450 j6	550	18,5	5

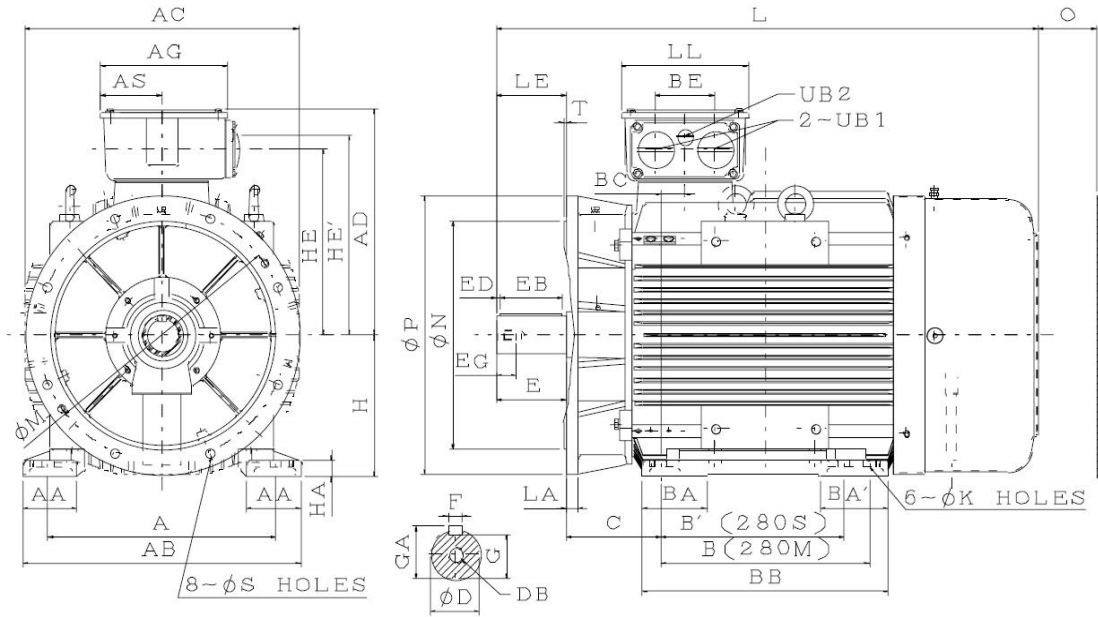

Figure 7-20: Outline drawing of cast iron design, mounting B35; frame size 280

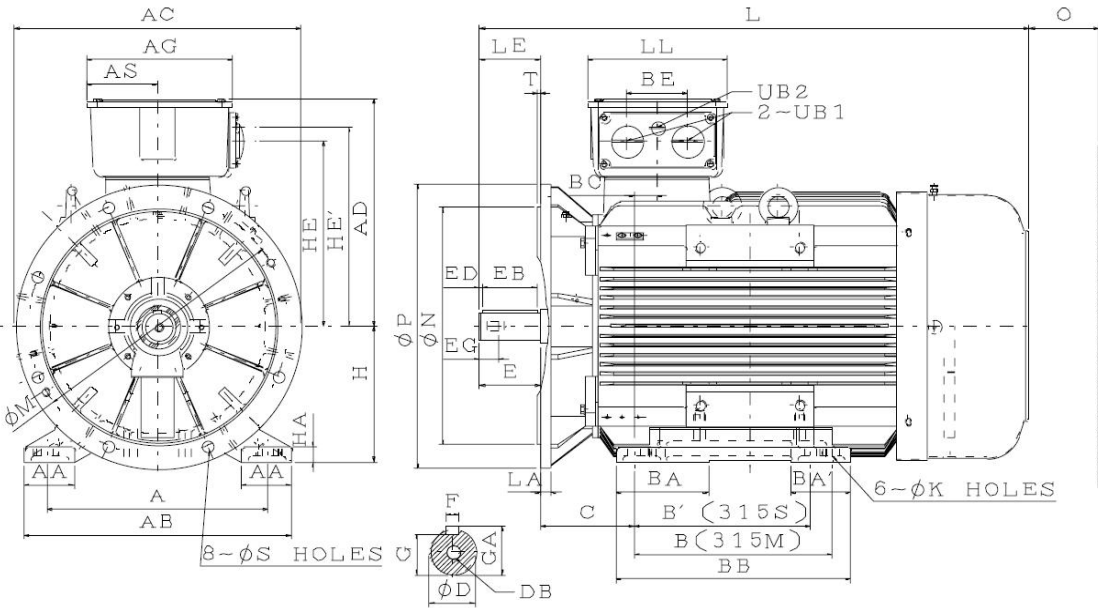

Figure 7-21: Outline drawing of cast iron design, mounting B35; frame size 315S – 315M

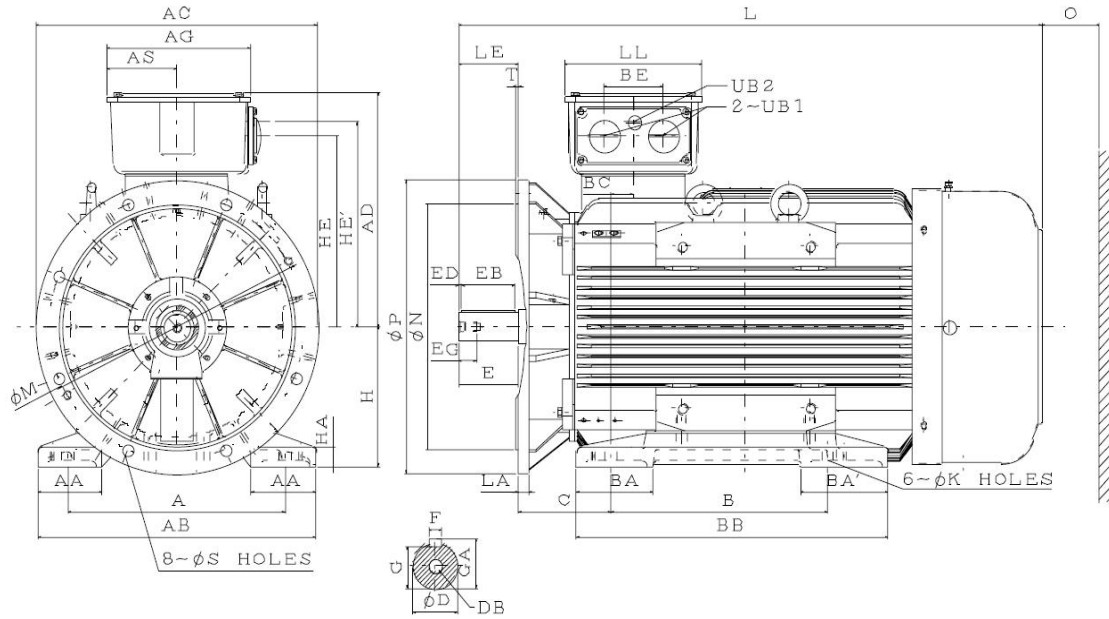

Figure 7-22: Outline drawing of cast iron design, mounting B35; frame size 315L

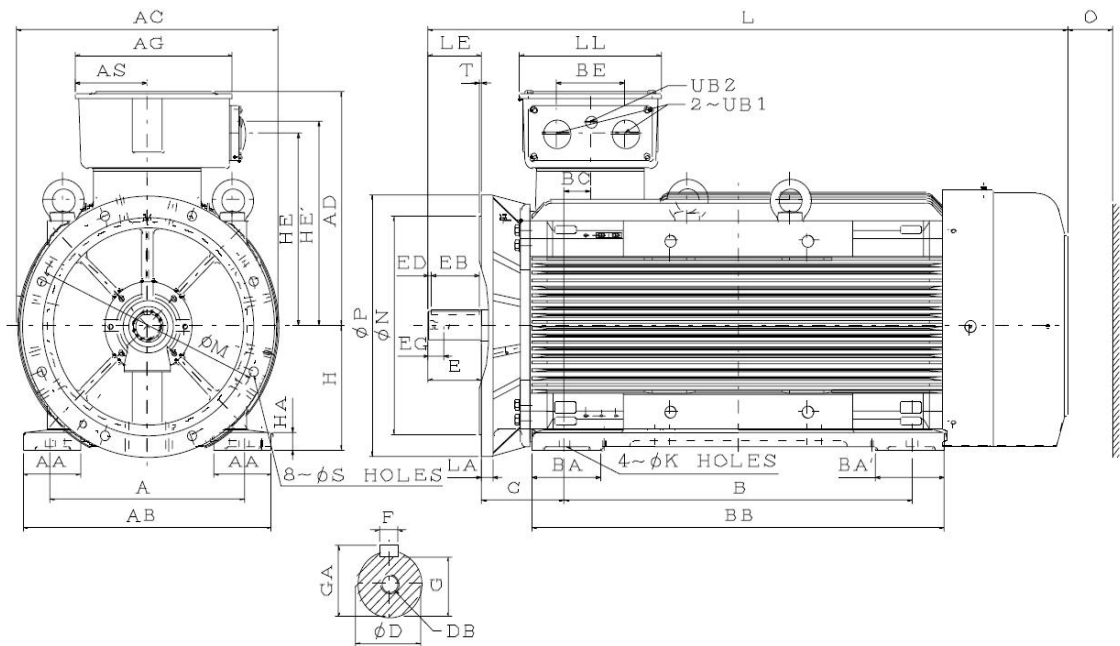

Figure 7-23: Outline drawing of cast iron design, mounting B35; frame size 315D

Outline dimensions of cast iron design, flange/feet version, mounting B35, frame size 280 – 315, dimensions in [mm]																				
Frame size	A	AA	AB	AC	AD	AG	AS	B	B'	BA	BA'	BB	BE	BC	C	H	HA	HE	HE'	
280	S	457	110	560	550	446	255	122,5	—	368	130	137	495	119	48	190	280	32	367	394
	S*	457	110	560	550	446	255	122,5	—	368	130	137	495	119	48	190	280	32	367	394
	S**	457	110	560	550	446	255	122,5	—	368	130	137	495	119	48	190	280	32	367	394
280	M	457	110	560	550	446	255	122,5	419	—	130	137	495	119	48	190	280	32	367	394
	M*	457	110	560	550	446	255	122,5	419	—	130	137	495	119	48	190	280	32	367	394
	M**	457	110	560	550	446	255	122,5	419	—	130	137	495	119	48	190	280	32	367	394
315	S	508	115	615	660	527	336	163	—	406	213	137	540	140	53	216	315	35	430	460
	S*	508	115	615	660	527	336	163	—	406	213	137	540	140	53	216	315	35	430	460
	S**	508	115	615	660	527	336	163	—	406	213	137	540	140	53	216	315	35	430	460
315	M	508	115	615	660	527	336	163	457	—	213	137	540	140	53	216	315	35	430	460
	M*	508	115	615	660	527	336	163	457	—	213	137	540	140	53	216	315	35	430	460
	M**	508	115	615	660	527	336	163	457	—	213	137	540	140	53	216	315	35	430	460
315	L	508	150	650	660	527	336	163	508	—	180	205	730	140	53	216	315	45	430	460
	L*	508	150	650	660	527	336	163	508	—	180	205	730	140	53	216	315	45	430	460
	L**	508	150	650	660	527	336	163	508	—	180	205	730	140	53	216	315	45	430	460
315	D	508	150	650	682	590	412	189	900	—	255	255	1080	180	68	216	315	45	485	515
	D*	508	150	650	682	590	412	189	900	—	255	255	1080	180	68	216	315	45	485	515
	D**	508	150	650	682	590	412	189	900	—	255	255	1080	180	68	216	315	45	485	515

*) = 4-, 6- and 8-pole version
 **) = 4-, 6-, 8-pole version; 315D frame with optional roller bearing

Frame size	Overall dimensions						Shaft extension										Bearings		
	K	L	LL	O	UB1	UB2	D	E	EB	ED	EG	F	G	GA	DB	at DE	at NDE	Fig.	
280	S	24,0	1087,5	255	—	M63 x 1,5	M20 x 1,5	65m6	140	125	7,5	42	18	58,0	69,0	M20	6316C3	6314C3	7-20
	S*	24,0	1087,5	255	—			75m6	140	125	7,5	42	20	67,5	79,5	M20	6318C3	6316C3	7-20
	S**	24,0	1087,5	255	—			75m6	140	125	7,5	42	20	67,5	79,5	M20	NU318	6316C3	7-20
280	M	24,0	1087,5	255	—			65m6	140	125	7,5	42	18	58,0	69,0	M20	6316C3	6314C3	7-20
	M*	24,0	1087,5	255	—			75m6	140	125	7,5	42	20	67,5	79,5	M20	6318C3	6316C3	7-20
	M**	24,0	1087,5	255	—			75m6	140	125	7,5	42	20	67,5	79,5	M20	NU318	6316C3	7-20
315	S	28	1266	322	—	M63 x 1,5	M20 x 1,5	65m6	140	125	7,5	42	18	58	69	M20	6316C3	6314C3	7-21
	S*	28	1296	322	—			80m6	170	160	5	42	22	71	85	M20	6320C3	6316C3	7-21
	S**	28	1296	322	—			80m6	170	160	5	42	22	71	85	M20	NU320	6316C3	7-21
315	M	28	1266	322	—	M63 x 1,5	M20 x 1,5	65m6	140	125	7,5	42	18	58	69	M20	6316C3	6314C3	7-21
	M*	28	1296	322	—			80m6	170	160	5	42	22	71	85	M20	6320C3	6316C3	7-21
	M**	28	1296	322	—			80m6	170	160	5	42	22	71	85	M20	NU320	6316C3	7-21
315	L	28	1366	322	—	M63 x 1,5	M20 x 1,5	65m6	140	125	7,5	42	18	58	69	M20	6316C3	6314C3	7-22
	L*	28	1396	322	—			80m6	170	160	5	42	22	71	85	M20	6320C3	6316C3	7-22
	L**	28	1396	322	—			80m6	170	160	5	42	22	71	85	M20	NU320	6316C3	7-22
315	D	28	1674	372	—	M63 x 1,5	M20 x 1,5	65m6	140	125	7,5	42	18	58	69	M20	6316C3	6316C3	7-23
	D*	28	1704	372	—			85m6	170	160	5	42	22	76	90	M20	6322C3	6322C3	7-23
	D**	28	1704	372	—			95m6	170	160	5	50	25	86	100	M24	NU322	6322C3	7-23

*) = 4-, 6- and 8-pole version
 **) = 4-, 6-, 8-pole version; 315D frame with optional roller bearing

Frame size		Flange dimensions						
		LA	LE	M	N	P	S	T
280	S	22	140	500	450	550	18,5	5
	S*	22	140	500	450	550	18,5	5
	S**	22	140	500	450	550	18,5	5
280	M	22	140	500	450	550	18,5	5
	M*	22	140	500	450	550	18,5	5
	M**	22	140	500	450	550	18,5	5
315	S	25	140	600	550	660	24	6
	S*	25	170	600	550	660	24	6
	S**	25	170	600	550	660	24	6
315	M	25	140	600	550	660	24	6
	M*	25	170	600	550	660	24	6
	M**	25	170	600	550	660	24	6
315	L	25	140	600	550	660	24	6
	L*	25	170	600	550	660	24	6
	L**	25	170	600	550	660	24	6
315	D	30	140	600	550	660	24	6
	D*	30	170	600	550	660	24	6
	D**	30	170	600	550	660	24	6

*) = 4-, 6- and 8-pole version
 **) = 4-, 6-, 8-pole version; 315D frame with optional roller bearing

7.2.4 Cast iron design; V1

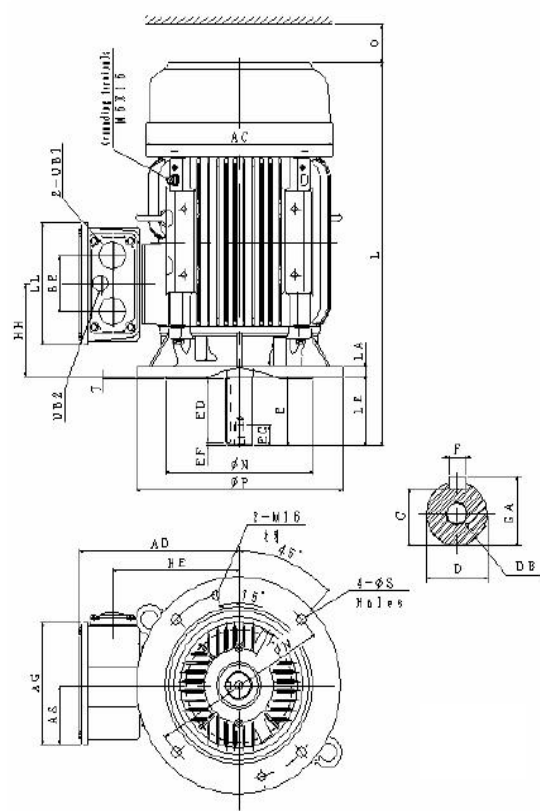

Figure 7-24: Outline drawing of cast iron design, mounting V1; frame size 160

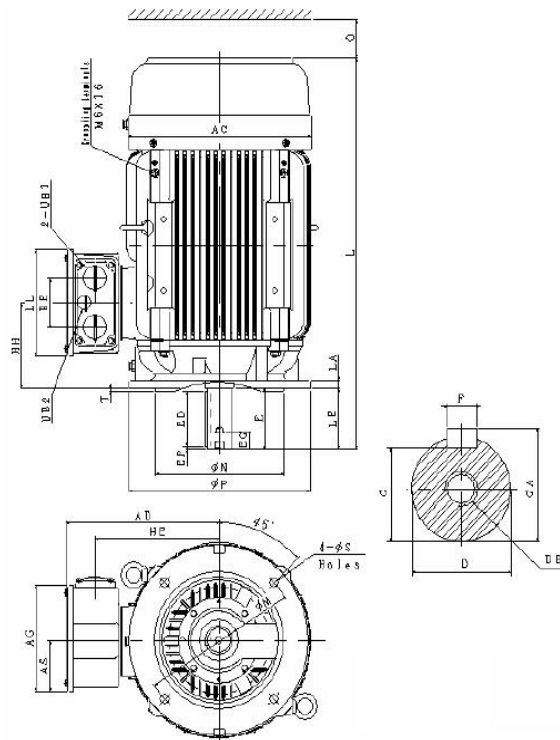

Figure 7-25: Outline drawing of cast iron design, mounting V1; frame size 180

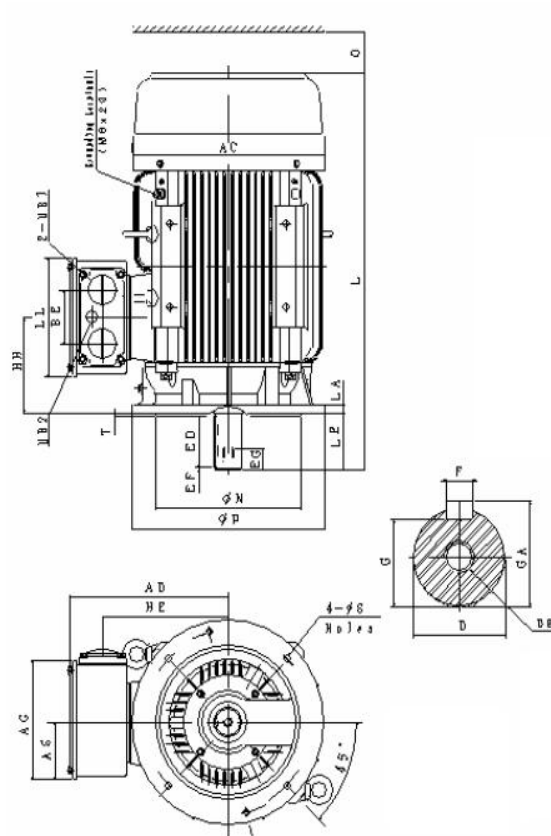

Figure 7-26: Outline drawing of cast iron design, mounting V1; frame size 200

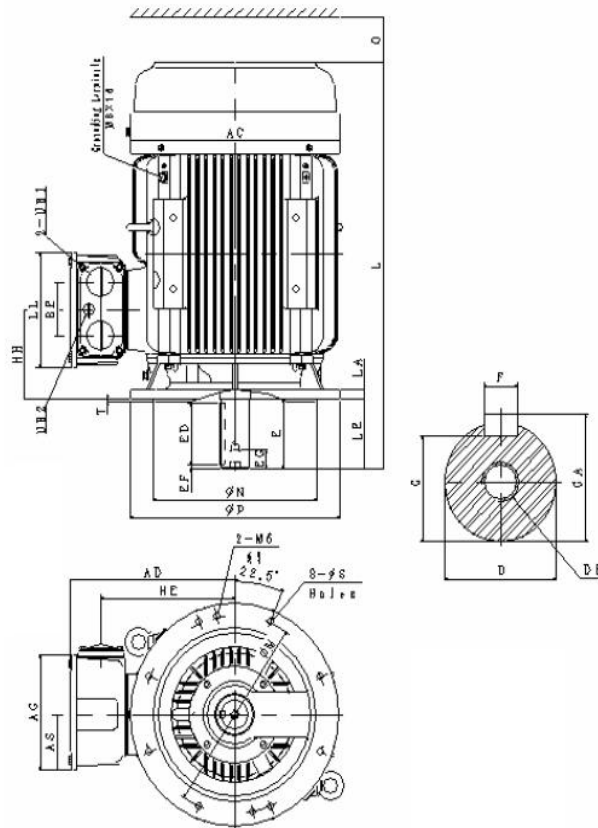

Figure 7-27: Outline drawing of cast iron design, mounting V1; frame size 225 – 250

Frame size		Outline dimensions of cast iron design, flange version, vertical mounting V1, frame size 160 – 250, dimensions in [mm]																		
		Flange dimensions																		
		AC	AD	AG	AS		BE	HH	HE	HE'		LA	LE	M	N	P	S	T		
160	S																			
	M	317	271	193	91,5		89	146	215		15	110	300	250j6	350	18,5	5			
	L	317	271	193	91,5		89	146	215		15	110	300	250j6	350	18,5	5			
180	S																			
	M	354	297	193	91,5		89	155	241		15	110	300	250j6	350	18,5	5			
	L	354	297	193	91,5		89	155	241		15	110	300	250j6	350	18,5	5			
200	S																			
	M																			
	L	398	330	231	110,5		106	193	262		17	110	350	300j6	400	18,5	5			
225	S	449	356	231	110,5		106	186,5	288		20	140	400	350j6	450	18,5	5			
	M	449	356	231	110,5		106	186,5	288		20	110	400	350j6	450	18,5	5			
	M*	449	356	231	110,5		106	186,5	288		20	140	400	350j6	450	18,5	5			
250	S																			
	M	498	398	255	122,5		119	225,5	322		22	140	500	450j6	550	18,5	5			
	M*	498	398	255	122,5		119	225,5	322		22	140	500	450j6	550	18,5	5			

*) = 4-, 6- and 8-pole version

Frame size		Overall dimensions					Shaft extension										Bearings			
		L	LL	O	UB1	UB2	D	E	EF	ED	EG	F	G	GA	DB	at DE	at NDE	Fig.		
160	S																			
	M	608	193	60	M40 x 1,5	M20 x 1,5	42k6	110	5	100	36	12	37	45	M16	6309ZZC3	6307ZZC3	7-24		
	L	652	193	60			42k6	110	5	100	36	12	37	45	M16	6309ZZC3	6307ZZC3	7-24		
S																				
180	M	672	193	70			48k6	110	5	100	36	14	42,5	51,5	M16	6311C3	6310C3	7-25		
	L	710	193	70			48k6	110	5	100	36	14	42,5	51,5	M16	6311C3	6310C3	7-25		
	S																			
200	M				M50 x 1,5	M20 x 1,5														
	L	770	231	80			55m6	110	5	100	42	16	49	59	M20	6312C3	6212C3	7-26		
	S																			
225	M	816	231	90			60m6	140	7,5	125	42	18	53	64	M20	6313C3	6213C3	7-27		
	M*	811	231	90			55m6	110	5	100	42	16	49	59	M20	6312C3	6212C3	7-27		
	S						60m6	140	7,5	125	42	18	53	64	M20	6313C3	6213C3	7-27		
250	M	921	255	105	M63 x 1,5	M20 x 1,5	60m6	140	7,5	125	42	18	53	64	M20	6313C3	6313C3	7-27		
	M*	921	255	105			65m6	140	7,5	125	42	18	58	69	M20	6315C3	6313C3	7-27		
	S																			

*) = 4-, 6- and 8-pole version

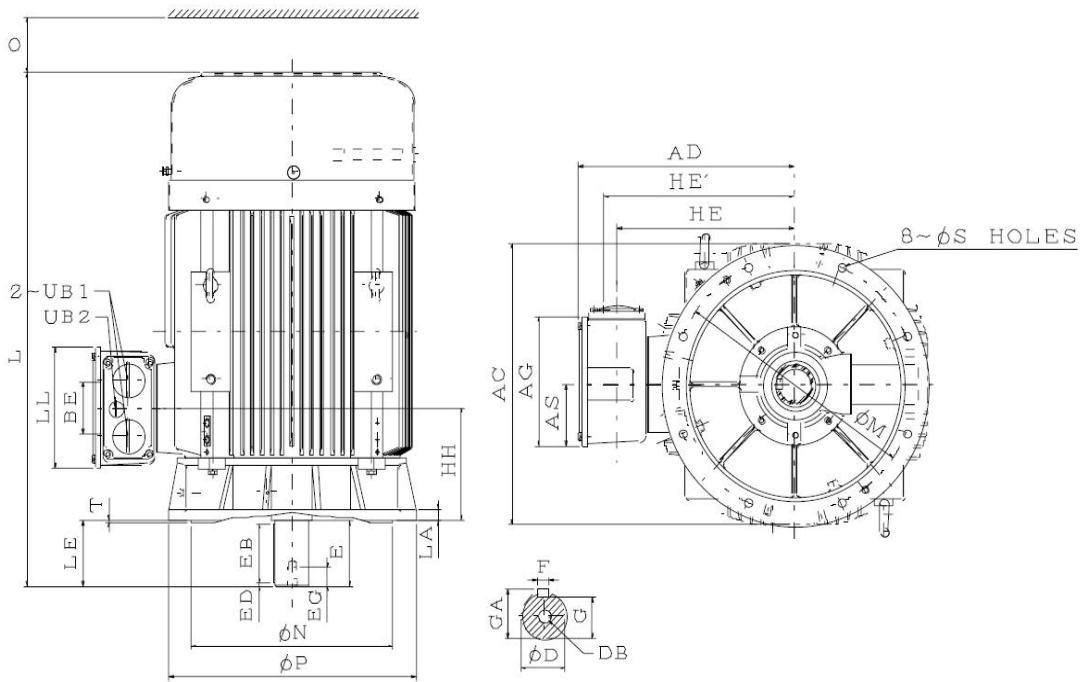

Figure 7-28: Outline drawing of cast iron design, mounting V1; frame size 280

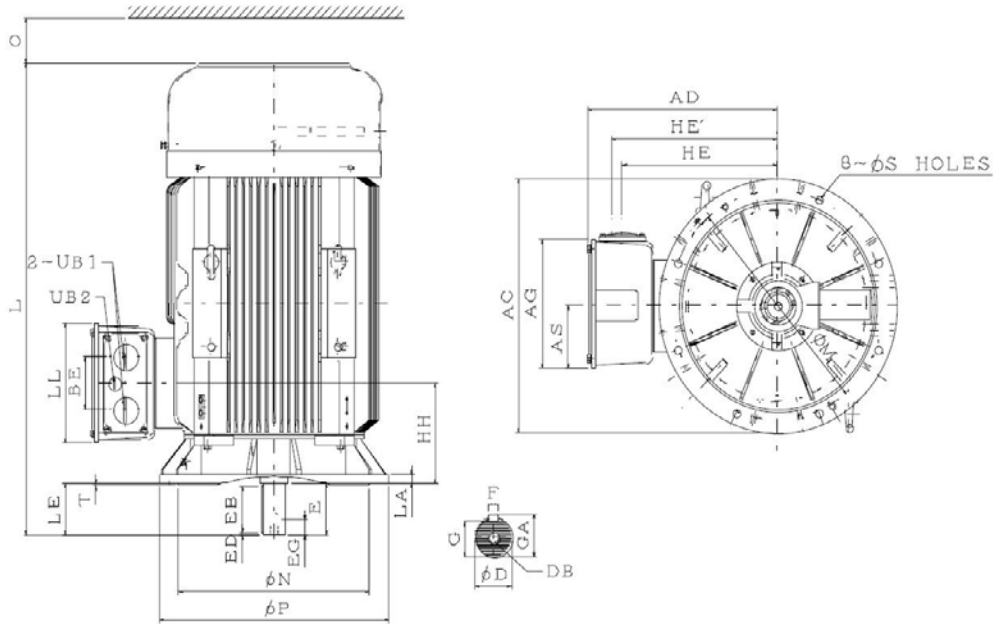

Figure 7-29: Outline drawing of cast iron design, mounting V1; frame size 315S – 315M

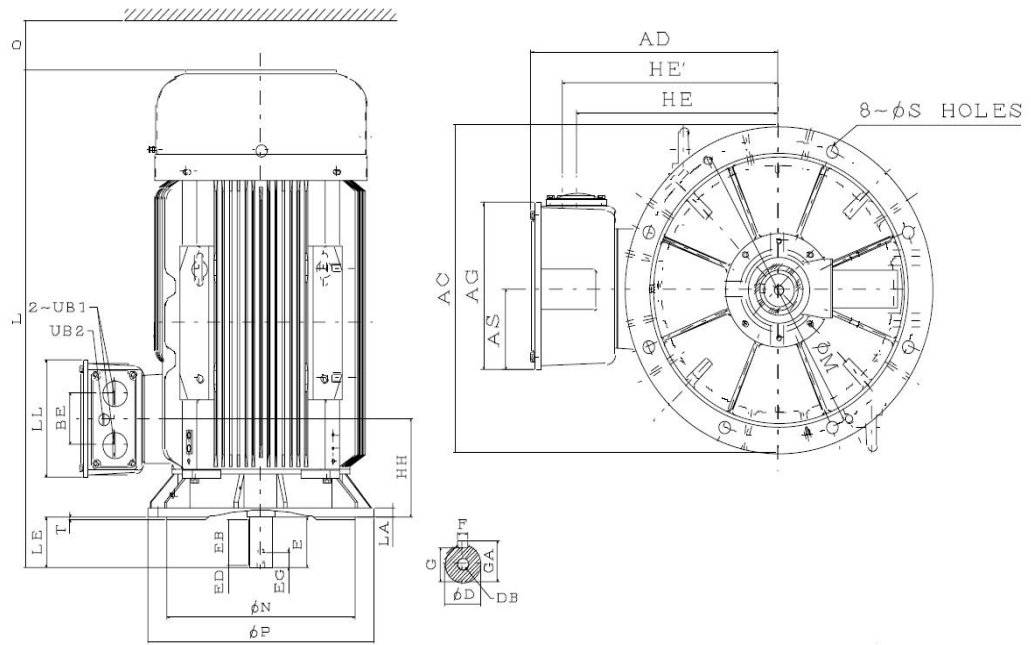

Figure 7-30: Outline drawing of cast iron design, mounting V1; frame size 315L

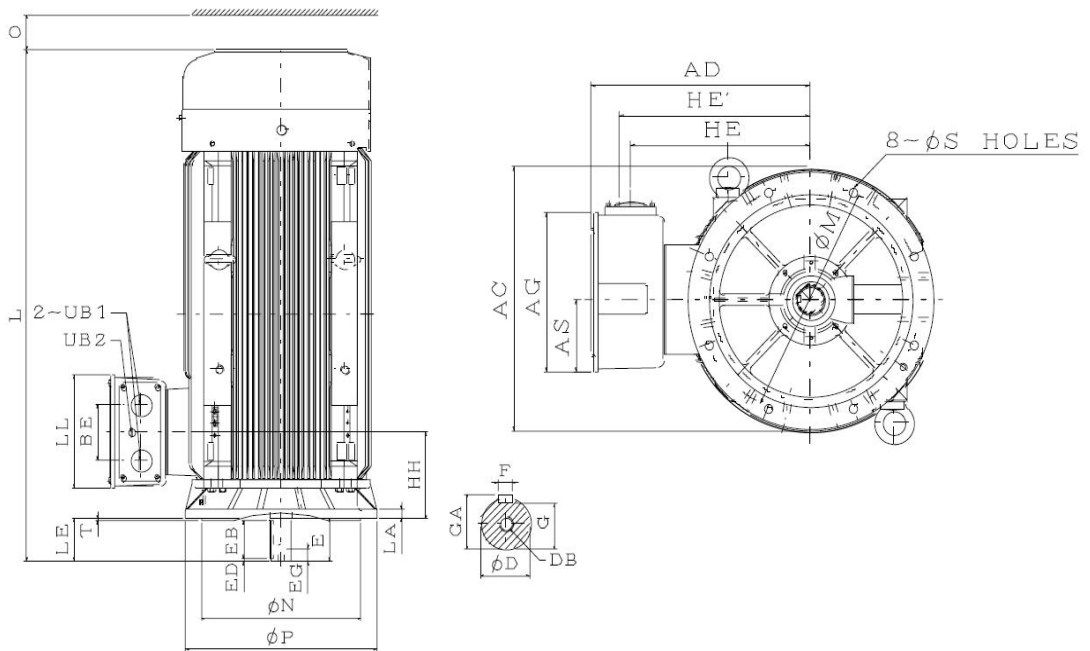

Figure 7-31: Outline drawing of cast iron design, mounting V1; frame size 315D

Frame size		Outline dimensions of cast iron design, flange version vertical, mounting V1, frame size 280 – 315, dimensions in [mm]																		
		Flange dimensions																		
		AC	AD	AG	AS		BE	HH	HE	HE'		LA	LE	M	N	P	S	T		
280	S	550	446	255	122,5		119	238	367	394		22	140	500	450	550	18,5	5		
	S*	550	446	255	122,5		119	238	367	394		22	140	500	450	550	18,5	5		
	S**	550	446	255	122,5		119	238	367	394		22	140	500	450	550	18,5	5		
280	M	550	446	255	122,5		119	238	367	394		22	140	500	450	550	18,5	5		
	M*	550	446	255	122,5		119	238	367	394		22	140	500	450	550	18,5	5		
	M**	550	446	255	122,5		119	238	367	394		22	140	500	450	550	18,5	5		
315	S	660	527	336	163		140	269	430	460		25	140	600	550	660	24	6		
	S*	660	527	336	163		140	269	430	460		25	170	600	550	660	24	6		
	S**	660	527	336	163		140	269	430	460		25	170	600	550	660	24	6		
315	M	660	527	336	163		140	269	430	460		25	140	600	550	660	24	6		
	M*	660	527	336	163		140	269	430	460		25	170	600	550	660	24	6		
	M**	660	527	336	163		140	269	430	460		25	170	600	550	660	24	6		
315	L	660	527	336	163		140	269	430	460		25	140	600	550	660	24	6		
	L*	660	527	336	163		140	269	430	460		25	170	600	550	660	24	6		
	L**	660	527	336	163		140	269	430	460		25	170	600	550	660	24	6		
315	D	682	590	412	189		180	284	485	515		30	140	600	550	660	24	6		
	D*	682	590	412	189		180	284	485	515		30	170	600	550	660	24	6		
	D**	682	590	412	189		180	284	485	515		30	170	600	550	660	24	6		

*) = 4-, 6- and 8-pole version

***) = 4-, 6-, 8-pole version; 315D frame with optional roller bearing

Frame size		Overall dimensions					Shaft extension										Bearings		
		L	LL	O	UB1	UB2	D	E	EB	ED	EG	F	G	GA	DB	at DE	at NDE	Fig.	
280	S	1087,5	255	—	M63 x 1,5	M20 x 1,5	65m6	140	125	7,5	42	18	58,0	69,0	M20	6316C3	6314C3	7-28	
	S*	1087,5	255	—			75m6	140	125	7,5	42	20	67,5	79,5	M20	6318C3	6316C3	7-28	
	S**	1087,5	255	—			75m6	140	125	7,5	42	20	67,5	79,5	M20	NU318	6316C3	7-28	
280	M	1087,5	255	—	M63 x 1,5	M20 x 1,5	65m6	140	125	7,5	42	18	58,0	69,0	M20	6316C3	6314C3	7-28	
	M*	1087,5	255	—			75m6	140	125	7,5	42	20	67,5	79,5	M20	6318C3	6316C3	7-28	
	M**	1087,5	255	—			75m6	140	125	7,5	42	20	67,5	79,5	M20	NU318	6316C3	7-28	
315	S	1266	322	—	M63 x 1,5	M20 x 1,5	65m6	140	125	7,5	42	18	58	69	M20	7316C3	6314C3	7-29	
	S*	1296	322	—			80m6	170	160	5	42	22	71	85	M20	6320C3	6316C3	7-29	
	S**	1296	322	—			80m6	170	160	5	42	22	71	85	M20	NU320	6316C3	7-29	
315	M	1266	322	—	M63 x 1,5	M20 x 1,5	65m6	140	125	7,5	42	18	58	69	M20	7316C3	6314C3	7-29	
	M*	1296	322	—			80m6	170	160	5	42	22	71	85	M20	6320C3	6316C3	7-29	
	M**	1296	322	—			80m6	170	160	5	42	22	71	85	M20	NU320	6316C3	7-29	
315	L	1366	322	—	M63 x 1,5	M20 x 1,5	65m6	140	125	7,5	42	18	58	69	M20	7316C3	6314C3	7-30	
	L*	1396	322	—			80m6	170	160	5	42	22	71	85	M20	6320C3	6316C3	7-30	
	L**	1396	322	—			80m6	170	160	5	42	22	71	85	M20	NU320	6316C3	7-30	
315	D	1674	372	—	M63 x 1,5	M20 x 1,5	65m6	140	125	7,5	42	18	58	69	M20	7316C3	6316C3	7-31	
	D*	1704	372	—			85m6	170	160	5	42	22	76	90	M20	6322C3	6322C3	7-31	
	D**	1704	372	—			95m6	170	160	5	50	25	86	100	M24	NU322	6322C3	7-31	

*) = 4-, 6- and 8-pole version

***) = 4-, 6-, 8-pole version; 315D frame with optional roller bearing

8 Spare parts

Spare parts are available according to figures below. The schematic diagrams are only representative for a product group.

8.1 Aluminium motors

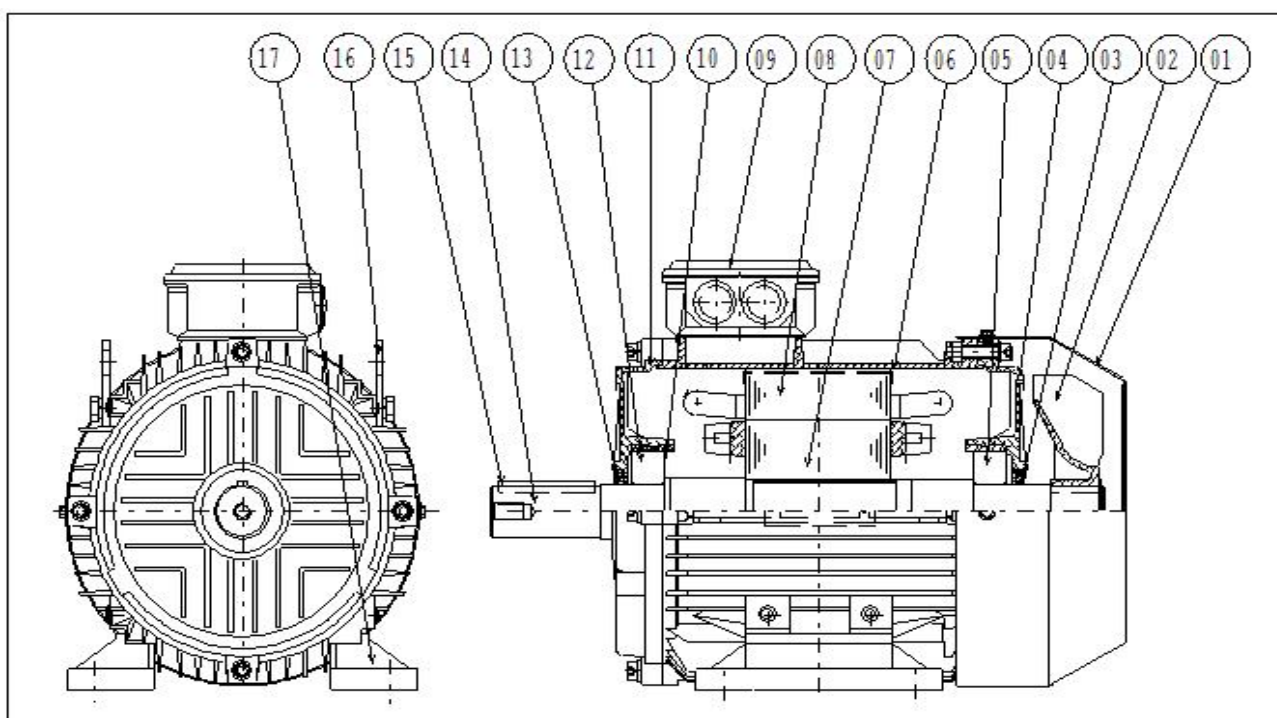

01 Fan cowl	08 Stator	15 Key
02 External fan	09 Terminal box	16 Lifting eye
03 Oil seal	10 Cir-Clip	17 Feet
04 NDE end shield	11 DE end shield	
05 Bearing	12 Bearing	
06 Frame	13 Oil seal	
07 Rotor	14 Shaft	

Figure 8-1: Schematic diagram of 63 – 132 frame aluminium motor, feet version

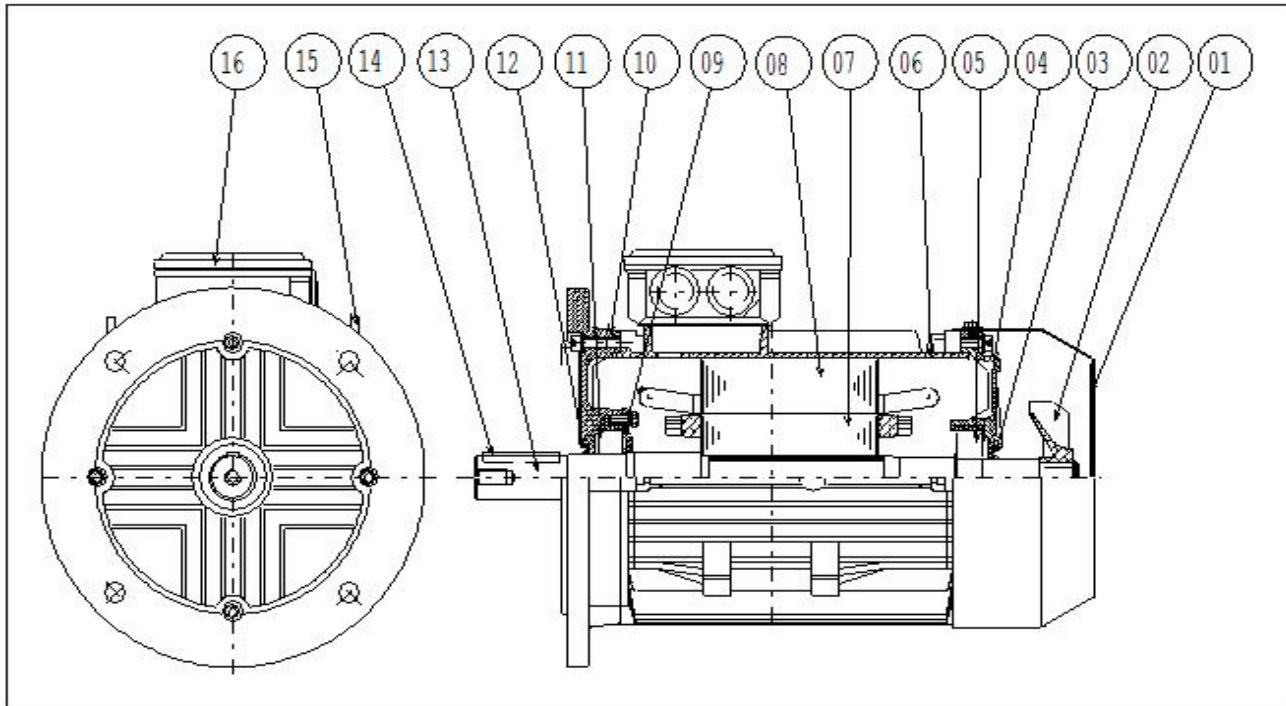

- | | | |
|-------------------|--------------------------|-----------------|
| 01 Fan cowl | 08 Stator | 15 Lifting eye |
| 02 External fan | 09 Inner bearing cover | 16 Terminal box |
| 03 Oil seal | 10 DE end shield, flange | |
| 04 NDE end shield | 11 Bearing | |
| 05 Bearing | 12 Oil seal | |
| 06 Frame | 13 Shaft | |
| 07 Rotor | 14 Key | |

Figure 8-2: Schematic diagram of a 160 aluminium motor, flange version

8.2 Cast iron motors

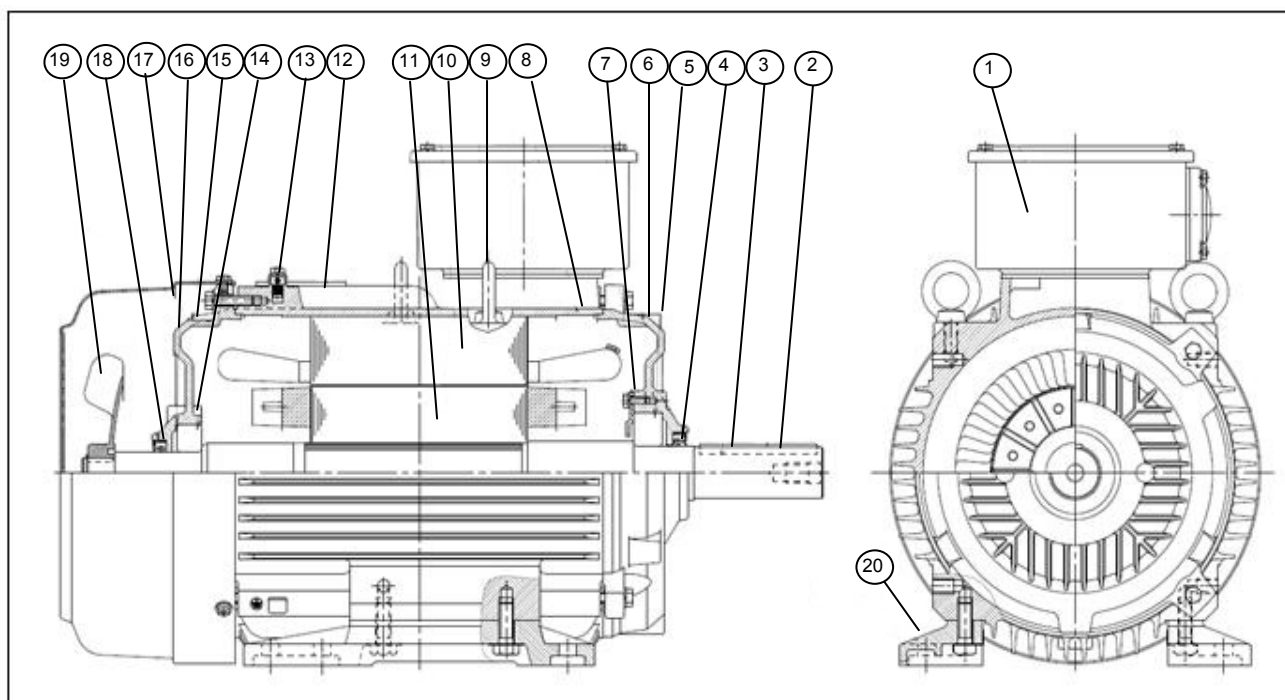

01 Terminal box	08 Frame	15 NDE end shield
02 Key	09 Lifting eye	16 Pre-load spring
03 Shaft	10 Stator	17 Fan cowl
04 Oil seal	11 Rotor	18 Oil seal
05 Bearing	12 Rating plate	19 External fan
06 DE end shield	13 Grounding terminal	20 Feet
07 Inner bearing cover	14 Bearing	

Figure 8-3: Cast iron motors; frame size ≤160 (sample)

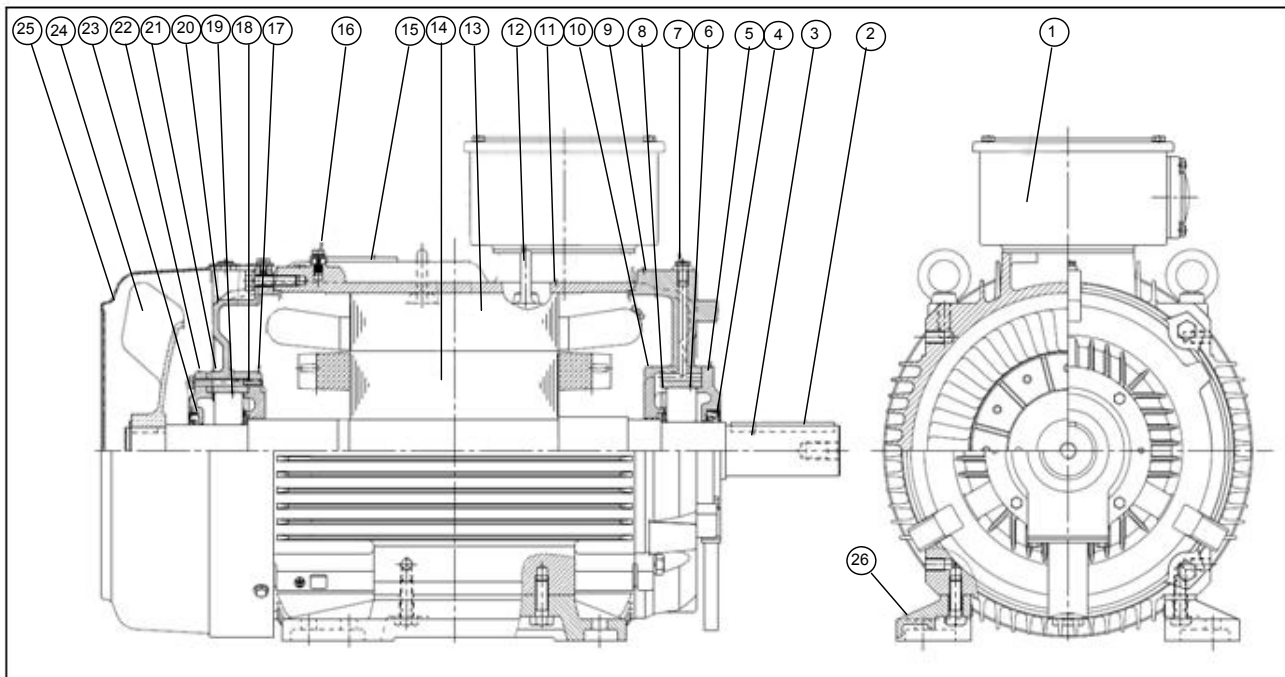

- | | | |
|------------------------|------------------------|------------------------|
| 01 Terminal box | 10 Inner bearing cover | 19 Bearing |
| 02 Key | 11 Frame | 20 NDE end shield |
| 03 Shaft | 12 Lifting eye | 21 Pre-load spring |
| 04 Oil seal | 13 Stator | 22 Outer bearing cover |
| 05 Outer bearing cover | 14 Rotor | 23 Oil seal |
| 06 Bearing | 15 Rating plate | 24 External fan |
| 07 Grease nipple | 16 Grounding terminal | 25 Fan cowl |
| 08 Bracket | 17 Inner bearing cover | 26 Feet |
| 09 DE end shield | 18 Bracket | |

Figure 8-4: Cast iron motors; frame size 180 – 280

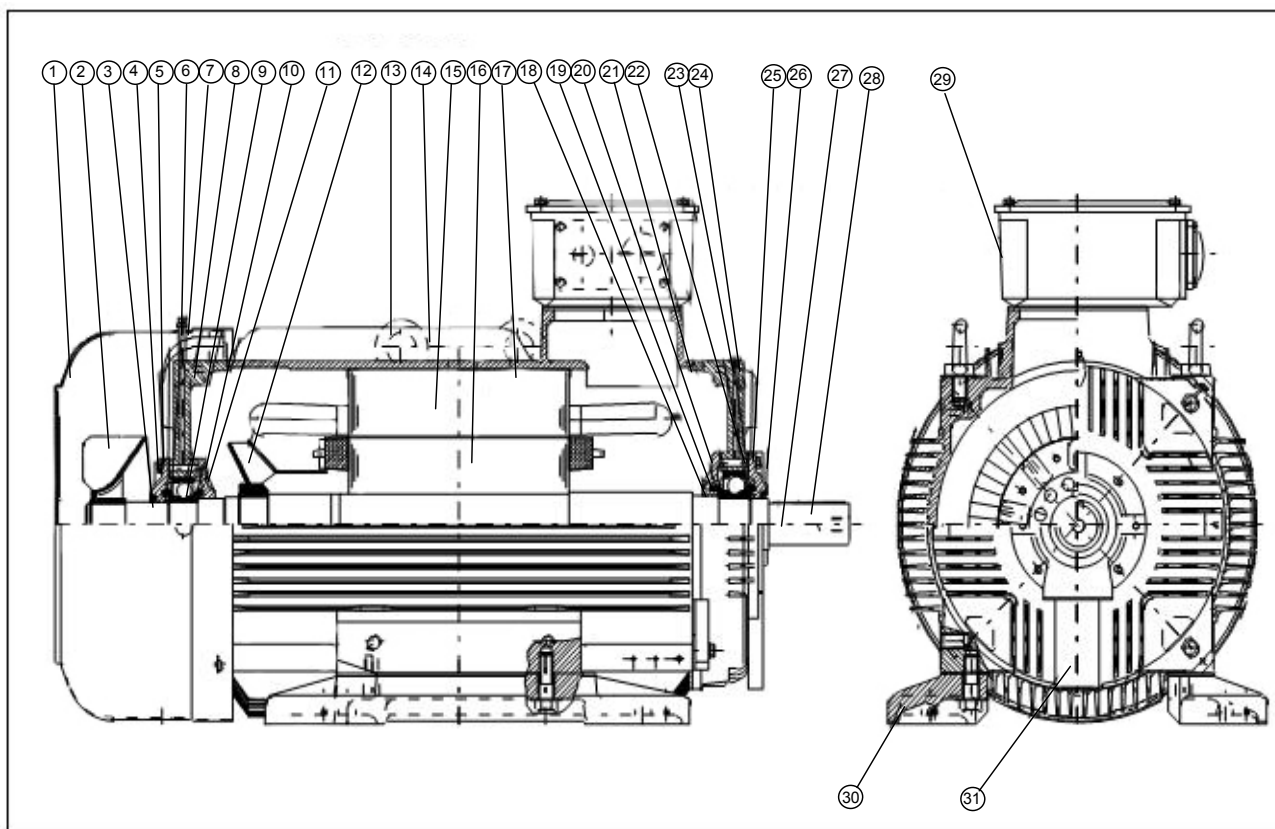

- | | | |
|---------------------------|------------------------|---------------------------|
| 01 Fan cowl | 12 Inner fan | 23 Outside retaining ring |
| 02 External fan | 13 Lifting eye | 24 Grease nipple |
| 03 Oil seal | 14 Rating plate | 25 Outer bearing cover |
| 04 Outer bearing cover | 15 Stator | 26 Oil seal |
| 05 Outside retaining ring | 16 Rotor | 27 Shaft |
| 06 Grease flinger | 17 Frame | 28 Key |
| 07 Grease nipple | 18 Inner bearing cover | 29 Terminal box |
| 08 DE end shield | 19 Grease flinger | 30 Feet |
| 09 Bearing | 20 Bearing | 31 Oil drain cover |
| 10 Grease flinger | 21 NDE end shield | |
| 11 Inner bearing cover | 22 Grease flinger | |

Figure 8-5: Cast iron motors; frame size 315; mounting B3

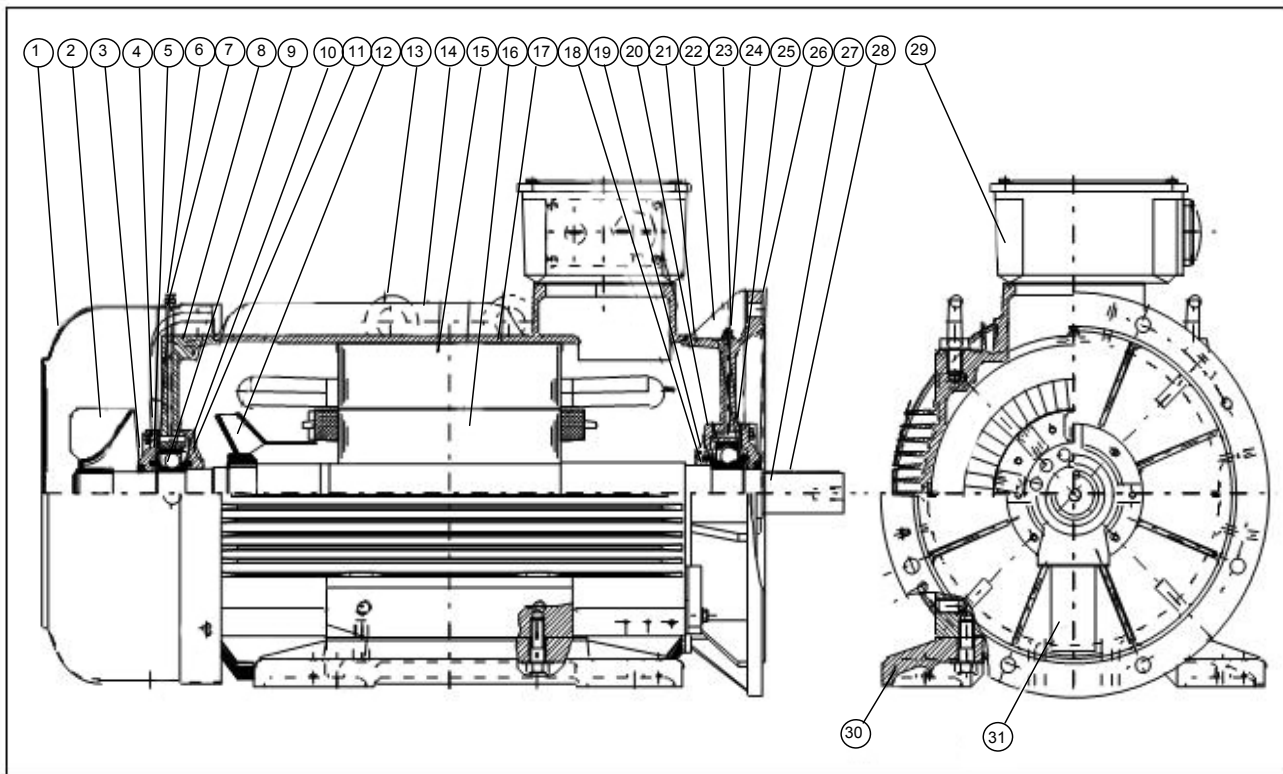

01 Fan cowl	12 Inner fan	23 Outside retaining ring
02 External fan	13 Lifting eye	24 Grease nipple
03 Oil seal	14 Rating plate	25 Outer bearing cover
04 Outer bearing cover	15 Stator	26 Oil seal
05 Outside retaining ring	16 Rotor	27 Shaft
06 Grease flinger	17 Frame	28 Key
07 Grease nipple	18 Inner bearing cover	29 Terminal box
08 DE end shield	19 Grease flinger	30 Feet
09 Bearing	20 Bearing	31 Oil drain cover
10 Grease flinger	21 NDE end shield	
11 Inner bearing cover	22 Grease flinger	

Figure 8-6: Cast iron motors; frame size 315; mounting B35

9 Packing, labelling

9.1 Packing design

If not otherwise specified, the motors are delivered as described below. Motors are appropriately packed for the shipping and transport method (mainly ship and truck). Within its individual cartons or crates the motors are sealed in foil to prevent spillage and mechanically fixed to avoid movement. A desiccant (like silica gel) is contained within the foil to prevent condensation.

9.1.1 Motors up to frame size 90

The motors are carton packed and placed on individually designed pallets. The motors cartons have two handling bars for carrying appropriate to withstand the motor weight. In a second function these handling bars give easy access to the nameplate of the motor. Therefore change of the brand label is possible without unpacking the motor.

The cartons can be piled in 1 – 3 layers on a pallet (see table below). The pallets for carton packed motors are designed for fork lifter use with similar fork access space (max. 145 mm centre blocks) as for euro pallets. (pallet dimensions see table below).

Frame size	Single carton dimensions	Max. pallet dimensions	Max. motors per unit	Max. mass, (depending on type)
	L x W x H	L x W x H		m
	[mm]	[mm]	pieces	[kg]
63	300 x 220 x 230	1100 x 800 x 900	52	
71	300 x 220 x 240	1100 x 800 x 900	52	
80	360 x 233 x 250	1100 x 800 x 900	30	730 – 900
90	450 x 250 x 270	1100 x 800 x 970	21	660 – 900

Table 9-1: Packing data of cartons and pallets

9.1.2 Motors frame size 100 to 315

The motors are packed in pallet based crates. It is possible to pile the crates according to table below:

Frame size	Single crate dimensions	Max. layer use	Max. pallet dimensions	Max. motors per unit	Max. mass, (depending on type)
	L x W x H		L x W x H		m
	[mm]	layers	[mm]	pieces	[kg]
100	530 x 350 x 385	3	1100 x 800 x 1000	18	900 – 1150
112	530 x 350 x 385	3	1050 x 930 x 900	12	750 – 1050
132	570 x 440 x 385	3	1160 x 800 x 1020	8	750 – 1050
160	750 x 450 x 590	3	750 x 900 x 720	2	300 – 425
180	840 x 490 x 625	3	980 x 840 x 1380	4	900 – 1250
200	990 x 580 x 740	2	990 x 590 x 750	1	300 – 400
225	990 x 580 x 740	2	990 x 590 x 750	1	370 – 520
250	1090 x 630 x 800	1	1090 x 630 x 800	1	500 – 650
280		1		1	
315		1		1	

Table 9-2: Packing data

9.2 Labelling

Each motor has an identification sticker which provides the following information encoded in clear text as well as in barcode (part of the 128 family).

The sticker is placed:

- with carton packed motors: on one side of the carton
- with crate packed motors: one sticker on side of the crate.

	Clear Text	Barcode
Article No.	X	X
Motor individual serial number	X	X
Catalogue No.	X	
Voltage	X	
Power	X	
Poles	X	
Mounting arrangement	X	

Table 9-3: Identification sticker contents

10 Quality assurance

According to the requirements of IEC 60 034-1 the following tests are carried out at least:

- Type test (for a certain type of motor) and
- Routine test (carried out on each individual motor).

The contents of these tests according to IEC are listed in the table below:

Code	Test Item	Type Test	Routine Test
1	Outline dimension inspection	X	X
2	Stator winding resistance (cold)	X	X
3	Insulation resistance (before high voltage test; item 8)	X	
4	Test of rotational direction	X	X
5	Locked rotor current	X	X
6.1	No load curve (current, power)	X	
6.2	Nominal no load point (current, power)	X	X
7.1	Heat run test	X	
7.2	Winding resistance hot (after heat run test)	X	
7.3	Losses segregation (evaluation of efficiency)	X	
8	High voltage test	X	X
9	Insulation resistance (after high voltage test; item 8)	X	X
10.1	Vibration test	X	
10.2	Acoustic noise test	X	

11 Documentation

Together with each motor the following documentation is delivered:

- Barcode label (see 9.2 Labelling, page 120)
- Safety instruction: A short form safety instructions according to demands of European directive 2006/95/EG is delivered together with each single motor (attached in carton box or safely fixed on eye bolt of crate packed motors). The manual is available in the most common EU languages.

The following documentation can be provided on request:

- A detailed start up and operation manual is available in English, German, French, Italian and Spanish language; it is available for download and as a hardcopy in TECO EU offices (TECO file name: "INSTALLATION, OPERATION and MAINTENANCE INSTRUCTIONS FOR TECO LOW VOLTAGE MOTORS TYPE ALAA and ALCA").
- EC certificate of conformity (Low Voltage Directive 2006/95/EC; EMC Directive 2004/108/EC)
- EC-Declaration of Incorporation according to Machinery Directive 2006/42/EC
- Data sheet and individual dimensional diagram
- Inspection certificate according to EN 10204: 2004.

EUROPE

Netherlands

Company Name: TECO Electric & Machinery B.V.
Address: Rivium 3e Straat 17
2909LH Capelle a/d IJssel
Country: Netherlands
Tel: 0031-(0)10-266-6633
Fax: 0031-(0)10-202-6415
Website: www.teco-group.eu

England

Company Name: TECO ELECTRIC EUROPE LTD.
Address: 7 Dakota Avenue
Salford. M50 2PU
Country: United Kingdom
Tel: 0044-161-877-8025
Fax: 0044-161-877-8030
Email: enquiries@teco-group.eu
Website: www.teco-group.eu

Germany

Company Name: TECO Electric and Machinery GmbH
Address 1: Bahnhofweg 7A
94060 Pocking
Country: Germany
Tel: 0049-(0)-8531-913874-0
Fax: 0049-(0)-8531-913874-9

Address 2: Poststrasse 6
37441 Bad Sachsa
Country: Germany
Tel: 0049-(0)-5523-9534-0
Fax: 0049-(0)-5523-9534-24
Website: www.teco-group.eu

Spain office

Company Name: Great TECO S.L.
Address: C/ Apostol Santiago, 40, 1A
28017 Madrid
Country: Spain
Tel: 0034-91-326-30-91
Fax: 0034-91-326-30-91
Website: www.teco-group.eu