

# TECO E510 Inverter

## Quick Start Guide

This guide is to assist you in installing and running the inverter and verify that it is functioning correctly for its main and basic features.

For detailed information and if there are any doubts please refer to the instruction manual.

### Step 1 Supply & Motor connection

- 1) Ensure that the Inverter & the motor have the correct KW power and voltage ratings.  
Motor full load amps must not exceed the Inverter rating.
- 2) Ensure that the supply & Motor cables are connected correctly prior to power up.
- 3) For single phase supply, use L1(L) & L3(N) on units which have 3 supply terminals.
- 4) Connect motor cable to terminals T1, T2 & T3.  
(Swap two leads if motor runs in reverse direction).
- 5) Connect supply Earth and the motor Earth to the drive Earth terminal.

#### Note:-

*1) For detailed installation and wiring refer to the Instruction manual.*



<b>Step 2</b>	<b>Apply power to the drive</b>
---------------	---------------------------------

Apply power to the drive, the display will briefly show the supply voltage 220V followed by 

5.00
------

 flashing.

This is the default (factory set) frequency.  
If the unit has been used previously then it will show the last frequency programmed.

<b>Step 3</b>	<b>Test run from keypad</b>
---------------	-----------------------------

Press **RUN KEY** to run.

The frequency will ramp up to **5.0 Hz** or the user **pre-set** frequency and according to the default acceleration ramp time.

Press **STOP** key to stop.

The frequency will ramp down to zero according to the default decel ramp time.

<b>Step 4</b>	<b>To alter frequency from keypad. (Default setting).</b>
---------------	---

Use the Arrow keys </RESET   and **READ/ENTER**

To alter the digits to the required frequency.  
eg. 50.0 HZ then use **RUN** and **STOP** keys to start / stop.

# Remote speed reference and Remote run

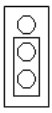
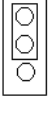
<b>Step 1</b>	<b>Remote mode wiring. Speed reference .</b>
<p>1) Ensure that you have carried out installation &amp; wiring requirements as per previous page before you proceed.</p> <p>2) For analogue signals 2-10V / 0-10V dc or 0-20mA / 4-20 mA.dc. Use either terminal AI1 or AI2. Check &amp; set Jumper bars JP2&amp;JP3 as required to position V (voltage) or I ( current) as below:</p> <div style="display: flex; justify-content: space-around; align-items: center;"> <div style="text-align: center;">  <p>V (Voltage)</p> </div> <div style="text-align: center;">  <p>I (Current)</p> </div> </div> <p>For remote potentiometer OR remote 2-10V / 0-10V dc signal use the following terminals:</p> <p>Terminal 10V.            The supply provided for use with the potentiometer. Terminal AI1 or AI2.    Potentiometer wiper connection. Terminal AGND.        0Vdc.</p> <p>For 0-20mA / 4-20mA signals use the following terminals: Terminal AI1 or AI2. Terminal AGND. 0Vdc.</p>	

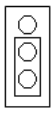
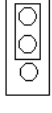
<b>Step 2</b>	<b>Remote mode Run</b>
<p>1) Remote Run signal can be either a PNP or NPN input type. Set PNP or NPN selection as required by Jumper JP1 as shown below: <b>Note: PNP ( positive voltage switching) selection is recommended for use in EU.</b></p> <div style="display: flex; justify-content: space-around; align-items: center;"> <div style="text-align: center;">  <p>PNP</p> </div> <div style="text-align: center;">  <p>NPN</p> </div> </div> <p>2) Connect remote start switch if required according to diagram in the instruction manual.</p> <p>Terminals 24V &amp; S1 (Forward run) Terminals 24V &amp; S2 (Reverse run) 24V is the common terminal for PNP type inverters. COM (0Vdc) terminal is common for the NPN type inverters.</p>	

<b>Step 3</b>	<b>Check/ verify and alter parameters</b>
---------------	---

Check / verify and alter parameters for remote start & remote frequency as necessary before you proceed. Parameters 00-02 & 00-05

*See quick start parameter list & How to alter parameters.*

<b>Step 4</b>	<b>RUN using remote speed reference. (Potentiometer 0-10vdc or 4 - 20ma )</b>
---------------	---

- 1) **To run.** Activate the remote run switch connected to terminals S1 ( FWD) or S2 ( REV) as required. Parameter 00-02 = 1

The frequency will ramp up to the **frequency** set by one of the following selections according to the set acceleration ramp time:-

- Potentiometer on the keypad Parameter 00-05 = 1
- External potentiometer. Parameter 00-05 = 2(AI1) or 3(AI2)
- External Analogue input Parameter 00-05 = 2(AI1) or 3(AI2)

- 2) **To Stop.** De-activate the remote run switch.

The frequency will ramp down to zero and according to the decel ramp time.

## How to alter parameters using the keypad

- 1) To alter parameters:- Press the **DSP/FUN** key, until the first parameter 00-00 is displayed.
- 2) Then use the arrow keys **</RESET ▲ ▼** to select the parameter required then Press **READ/ENTER** key to read the preset value.
- 3) Use the **▲ ▼** and **</RESET** keys to alter the setting of the parameters as per **basic quick start parameter list**.  
  
Note:- For full parameter list refer to the instruction manual.
- 4) To save each parameter change, press **READ/ENTER** key then the word **END** will be displayed.
- 5) Use **</RESET ▲ ▼** key to select the next parameter to alter and follow steps 2 to 4 until all changes are complete.
- 6) Pressing the **DSP/FUN** key repeatedly will alternate the display between the **preset frequency** (flashing display) and the last parameter accessed or other selectable displays 0 to 7 when selected by parameter 12-00 according to the table below.

**【0】 :Disable display    【1】 :Output Current    【8】 :Count Status**  
**【2】 :Output Voltage    【3】 :DC voltage**  
**【4】 :Temperature        【5】 :PID feedback**  
**【6】 :AI1                 【7】 :AI2**



## Basic Quick Start Parameter List

Parameter	Default	Range	Note
00-00	0	0-1	0: V/F control mode 1: Vector mode (SLV)
00-14	10.0	0.1~3600.0	Acceleration time in Secs
00-15	10.0	0.1~3600.0	Deceleration time in Secs
00-04	0	0-2	0: Forward/Stop-Reverse/Stop 1: Run/Stop-Reverse/Forward 2: 3-Wire Control Mode-Run/Stop
00-12	50/60Hz	0.01~650.00	Max frequency limit.
00-13	0.0	0.00~649.00	Min frequency limit
00-02	0	0-3	Start mode:- 0: Keypad 1: Remote 2: Communication 3: PLC
00-05	0	0-7	Main frequency source:- 0: Keypad 1: Potentiometer on keypad 2: External AI1 analogue signal 3: External AI2 analogue signal 4: External up/down frequency control 5: Control by Communication method 6: PID output 7: Pulse input
07-09	0	0-1	Stop method:- 0: Decel to stop 1: Coast to stop
02-01	**A	**A	Motor overload protection according to motor name plate
13-08	0000		Set to factory setting. 1150: 50HZ system 1160: 60HZ system 1112: Reset PLC

**Note:- For Full Parameter List see the Instruction manual**

# Control Modes & Auto Tune

E510 provides two control modes

Select the relevant control mode for the application, using parameter 00-00 Control mode.

Default control mode is V/f.

V/f can be used for most applications specifically multi-motor or applications where auto tune is not successful or when a customized v/f pattern may be required.

Several V/f patterns are available selectable by parameter 01-00.

Select the appropriate V/f pattern based on the application load type and the motor base frequency of 50 or 60 Hz.

For selections of the V/f patterns . Refer to the instruction manual.

For Vector modes SLV is used for obtaining best performance from a motor.

## V/f Mode Parameters:-

Parameter	Default	Range	Note
<b>01-00</b>	0/9	0-18	0= General Purpose. 50 Hz. System 9= General Purpose. 60Hz. System For full list of preset patterns set by 01-00, refer to the manual.  18= Customized V/f. Set parameters 01-01 to 01-09.

## SLV ( vector) mode set parameters in parameter Group 2 .

- 1) Set the motor parameters highlighted below in Group 2 from motor name plate data.
- 2) Ensure that the motor is connected correctly then,
- 3) Enable auto tune function by setting parameter 02-14= 1 ( auto tune Enable).

Auto tune type is Static. No rotation of the motor.

After Auto tune is completed successfully ( no errors) the motor stator & resistance values will be stored automatically in parameters 02-15 & 02-16.

Group 2 Parameters. Motor data & auto tune				
No.	Description	Range	Factory Setting	Unit
<b>02-00</b>	Motor No Load Current	----	-	Amps(AC)
<b>02-01</b>	Motor Rated Current (OL1)	----	-	A
<b>02-02</b>	Motor rated Slip Compensation	----	0.0	%
<b>02-03</b>	Motor rated speed	----	-	Rpm
<b>02-04</b>	Motor rated voltage	200V: 170.0~264.0 400V: 323.0~528.0	220.0/440.0	V
<b>02-05</b>	Motor rated power	----	-	KW
<b>02-06</b>	Motor rated frequency	0~650.0	50.0/60.0	Hz
<b>02-07</b>	Motor number of poles.	2 ~16	4	-
<b>02-14</b>	Auto Tune	0: Disable 1: Start Auto tune function.	0	
<b>02-15</b>	Stator resistance gain	----		
<b>02-16</b>	Rotor resistance gain	----		

# Standard wiring. Single phase

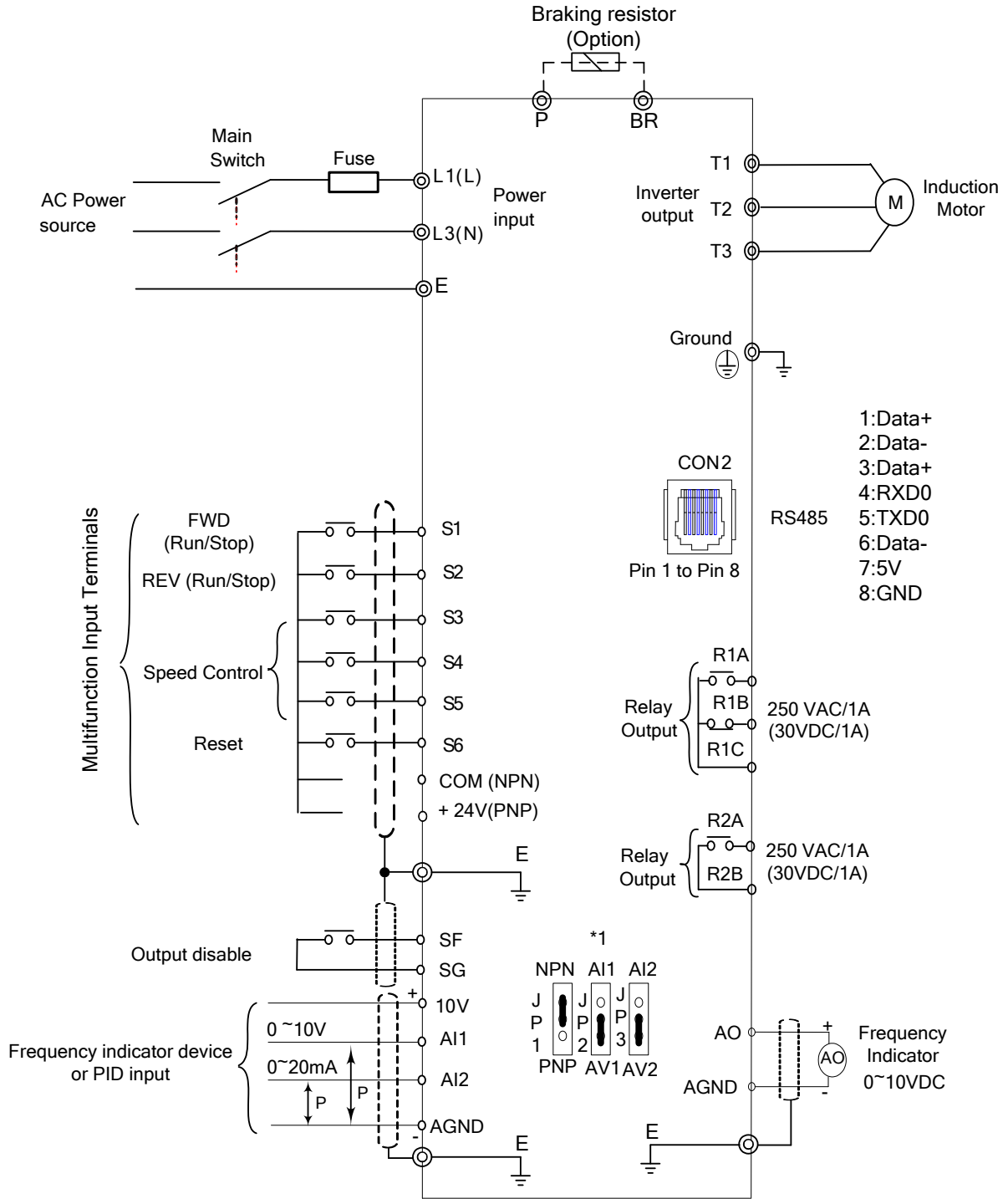

Ⓢ Indicates shield wire    ⓈP Indicates twisted-pair shield wire

⊙ Shows main circuit    ○ Shows control circuit

\*1: JP1:NPN/PNP selection, JP2:AI1 0~10V/0~20mA selection, JP3:AI2 0~10V/0~20mA selection

## Model:

200V: E510-2P5-H1F (N4S) / E510-201-H1F (N4S) / E510-202-H1F (N4S) / E510-203-H1F (N4S)



# Three phase

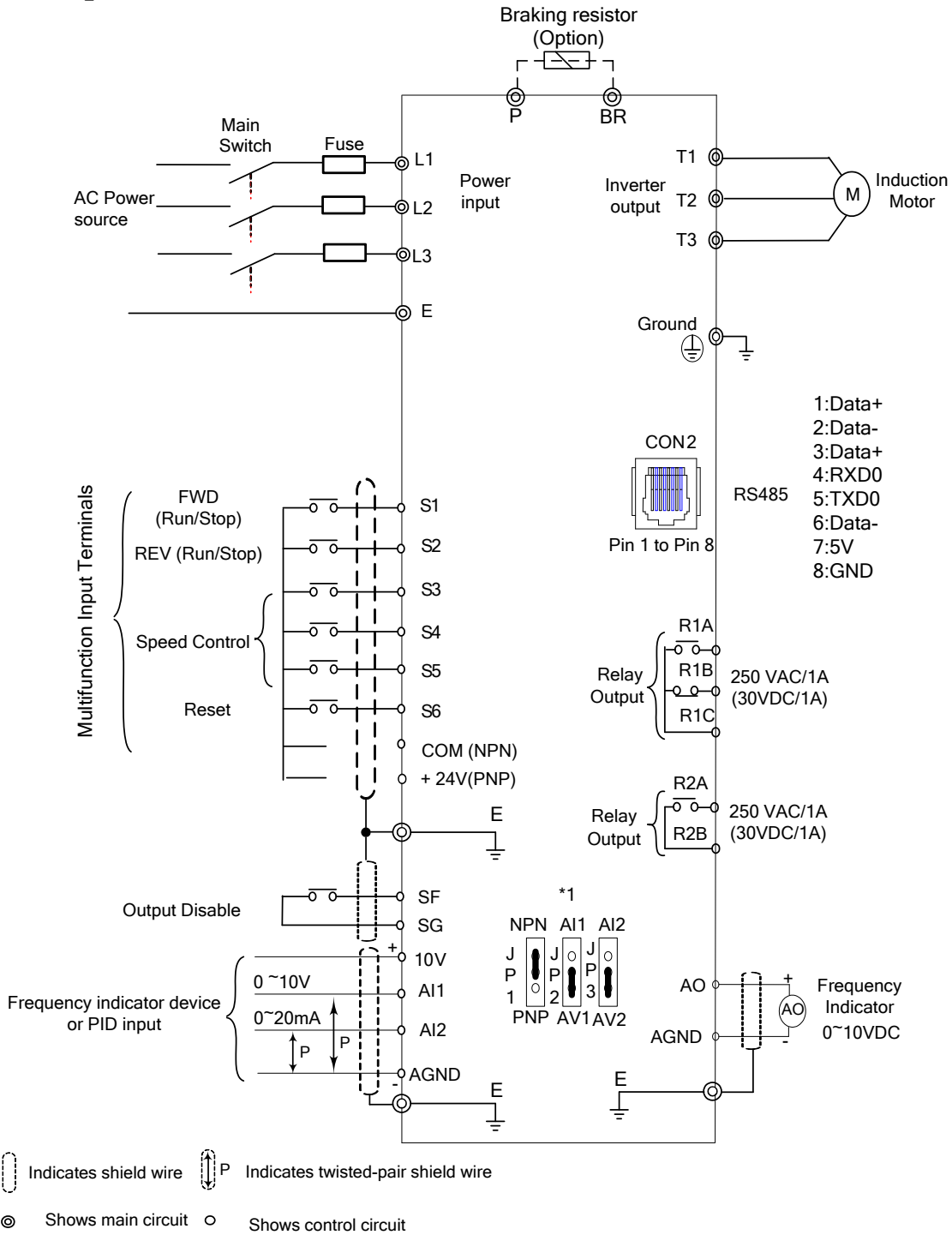

\*1: JP1:NPN/PNP selection, JP2:AI1 0~10V/0~20mA selection, JP3:AI2 0~10V/0~20mA selection

## Model:

**200V:** E510-202-H3 (N4) / E510-205-H3 (N4) / E510-208-H3 (N4) / E510-210-H3 (N4) / E510-215-H3 (N4) / E510-220-H3 (N4)

**400V:** E510-401-H3F (N4S) / E510-402-H3F (N4S) / E510-403-H3F (N4S) / E510-405-H3F (N4S) / E510-408-H3F (N4S) / E510-410-H3F (N4S) / E510-415-H3F (N4S) / E510-420-H3(F) (N4) / E510-425-H3(F) (N4)