

TECO A510 Inverter

Quick Start Guide

This guide is to assist you in installing and running the inverter and verify that it is functioning correctly for its main and basic features.

For detailed information and if there are any doubts please refer to the instruction manual.

Step 1 Supply & Motor connection

- 1) Ensure that the Inverter & the motor have the correct KW power and voltage ratings.
Motor full load amps must not exceed the Inverter rating.
- 2) Ensure that the supply & Motor cables are connected Correctly prior to power up.
- 3) Connect supply cable to terminals L1,L2& L3.
- 4) Connect motor cable to terminals T1,T2 &T3.
(Swap two leads If motor runs in reverses direction).
- 5) Connect supply Earth and the motor Earth to the drive Earth terminal.

Note:-

1) For detailed installation and wiring refer to the Instruction manual.



Step 2	Apply power to the drive
---------------	---------------------------------

Apply power to the drive, the display will briefly show the supply voltage 220V followed by

05.0

 flashing.

This is the default (factory set) frequency.

If the unit has been used previously then it will show the last frequency programmed.

Step 3	Test run from keypad
---------------	-----------------------------

Press **RUN KEY** to run.

The frequency will ram up to **5.0 Hz** or the user **pre-set** frequency and according to the default acceleration ramp time.

Press **STOP** key to stop.

The frequency will ramp down to zero according to the default decel ramp time.

Step 4	To alter frequency from keypad. (Default setting).
---------------	---

Use the Arrow keys **▲ ▼** and **< / RESET** key to alter the digits to the required frequency.

To store the set frequency use **READ/ENTER** Key eg. 50.0 HZ then use **RUN** and **STOP** keys to start/ stop.

Remote speed reference and Remote run

Step 1 Remote mode wiring. Speed reference and Run signals.

- 1) Ensure that you have carried out installation & wiring requirements as per step1 quick start guide on previous page before you proceed.
- 2) For analogue signal type. -10V to +10V or 0-10V dc. Use the terminal AI1 or AI2. Set SW2 in V position.

For analogue input type 4 -20mA. Use the terminal AI2. Set SW2 to I Position. (default).

Connect remote potentiometer OR remote 0-10 vdc signal as required. to terminals AI1 Or AI2.
Functions of AI1 & AI2 can be set by parameter 04-00 & 04-05.

Terminal + 12Vdc & -12Vdc is the supply provided for use with the potentiometer.
Terminals AI1 & AI2 are for potentiometer wiper connection.
Terminal GND is 0Vdc.
- 3) Connect remote start switch if required according to diagram in the instruction manual.
Use terminals +24Vdc & S1 (Forward run).

Step 2 Remote mode Run

- 1) Power up.
Display will read the frequency from one of the following according to the Connection made to AI1 or AI2 terminal. Set parameter 00-05 =0001
 - a) Remote external potentiometer
 - b) Remote 0-10VDC analog signal.

Step 3 Check/ verify and alter parameters

Check / verify and alter parameters for remote start & remote frequency as necessary before you proceed. Parameters 00-02 & 00=05

See quick start parameter list & How to alter parameters.

Step 4 **RUN using remote speed reference.**
(Potentiometer, 0-10vdc or 4-20ma)

1) **To run.** Activate the remote run switch connected to terminals S1 (FWD) or S2 (REV) as required,. Parameter 00-02=0001

The frequency will ram up to the **frequency** set by one of the Following and according to the set acceleration ramp time.

Select Analogue input 1 or 2 as required to set speed reference.

- External Analogue Input. Parameter 00-05 = 1

A11	Voltage Input. Speed command	0 to +10V, -10V to +10V
A12	Multi-function analog input terminal. Use SW2 to switch voltage or current input .	0 to +10V, -10V to +10V 4 to 20 mA

2) **To Stop.** De-activate the remote run switch. The frequency will ramp down to zero and according to decel ramp time.

How to alter Parameters from keypad

- 1) To alter parameters:- Press the **DISP/FUN** key, until the first parameter 00-00 is displayed.
- 2) Then use the arrow keys ▲ ▼ to select the parameter required then Press **READ / ENTER** key to read the preset value.
- 3) Use the ▲ ▼ and < / **RESET** keys to alter the setting of the parameters as per **basic quick start parameter list**.
Note:- For full parameter list refer to the instruction manual.
- 4) To save each parameter change, press **READ / ENTER** key then the word **END** will be displayed.
- 5) Use ▲ ▼ key to select the next parameter to alter and follow steps 2 to 4 until all changes are complete.
- 6) Pressing the **DISP/FUN** key repeatedly will alternate the display between the **preset frequency** (flashing display) and the last parameter accessed or other selectable displays 0 to 7 when selected by parameter 12-00 according to the table below.

- | | |
|-----------------------------|----------------------------|
| 【0】 :Disable display | 【1】 :output Current |
| 【2】 :output Voltage | 【3】 :DC bus voltage |
| 【4】 :Temperature | 【5】 :PID feedback |
| 【6】 :AI 1 .Value | 【7】 :AI2. Value |



Type	Name	Functions
Display	Main digital displays	Frequency, parameter, voltage, current, temperature and Fault message.
	LED status display	<p>FAULT: When the inverter has a warning or fault message, the indicator lights up.</p> <p>FWD: When the inverter is in forward run mode, the indicator lights up. RUN mode: Continuously ON. Stop mode:- Flashes ON/OFF. (inverter stopping)</p> <p>REV: When the inverter is in reverse Run mode, the indicator lights up. RUN mode: Continuously ON. Stop mode:- Flashes ON/OFF</p> <p>SEQ: When Run command source is set to external control, the indicator lights up.</p> <p>REF: When Frequency command source is set to external control, the indicator lights up.</p>
Keys (8 keys)	RUN	RUN: Run command at the set frequency.
	STOP	STOP: Stop command. Decelerate or Coast to stop.
	▲	Increments parameter number and preset values.
	▼	Decrements parameter number and preset values.
	FWD/REV	Sets Inverter speed and motor rotation direction.
	DSP/FUN	Select between Frequency, Function (parameters) and Monitor displays according to the following sequence. Frequency screen →Function selection→Monitor parameters→ Frequency screen.
	</RESET	"<" is left shift key. It is used for changing parameter or value. RESET key : Use to reset Inverter resettable faults .
	READ/ENTER	Used to display the preset value of parameters and for saving the changed parameter values.

Basic Quick Start Parameter List

Parameter	Default	Range	Note
00-00	0	0-4	Control Mode:- 0: V/F 1: V/F+PG (Encoder). 2: SLV (Sensorless Vector) 3: SV (Vector +Encoder) 4: PMSV (Permanent Magnet Motor + Encoder)
00-27	0	0-1	HD/ND selection. V/f Mode only 0: HD (Heavy duty load mode) 1: ND (Normal duty load mode)
00-02	00-00	0-2	Run mode:- Keypad = 0 Remote = 1 Communication = 2 PLC = 3
00-05	00-00	0-5	Frequency source:- 00-00 = keypad 00-01= Remote control (Analogue Inputs) 00-02= External up/down frequency control 00-03= Control by Communication 00-04 = Pulse Input 00-05 =PID output
00-01	000	0-1	Run Direction:- 0: Forward 1: Reverse
00-12	50/60Hz	0.1~109%	Max frequency limit. (default 100%)
00-13	0.0	0.0~109%	Min frequency limit. (default 0.0%)
01-02	50/60 Hz	Sets the max frequency limit in <u>all control modes</u>	<ul style="list-style-type: none"> • Programmable V/f . (01-00 = FF) HD = 400Hz ND = 120Hz • SLV. According to the table in the manual
07-09	000	0-1	Stop method: 00-00 = Decel to stop 00-01= Coast to stop 00-02= DC injection braking 00-03= Run signal inhibit (timer) during Coast to stop
02-01	**A	**A	Motor overload protection
13-08	000		Factory Reset: Inverter Supply voltage. 2 : 2 wire initialization(230/460V) 3 : 3 wire initialization(230/460V) 4 : 2 wire initialization(200/415V) 5 : 3 wire initialization(200/415V) 6 : 2 wire initialization(200/380V) 7 : 2 wire initialization(200/380V)

Note:- For Full Parameter List see the Instruction manual

Control Modes & Auto Tune

A510 provides five control modes

Select the relevant control mode for the application.

Default control mode is V/f.

V/f can be used for most applications specifically multi-motor or applications where auto tune is not successful or when a customized v/f pattern may be required.

Several V/f patterns are available selectable by parameter 01-00.

select the appropriate one based on the application load type and the motor base frequency of 50 or 60 Hz.

For selections of the V/f patterns . Refer to the instruction manual.

For Vector modes SLV & SV modes are used for obtaining best performance from a motor and in applications that require dynamic response to torque and speed change use SV + Encoder.

V/f Mode Parameters:-

Parameter	Default	Range	Note
01-00	F	0-FF	F= General Purpose. 60 Hz. system 0= General Purpose . 50Hz. System For full list of preset patterns set by 01-00, refer to the manual. FF= Customized V/f. Set parameters 01-02 to 01-13.

For Motor1 parameters in V/f mode, set the name plate data in parameters 02-00 to 02-19
Parameters 02-09 to 02-19. Not normally need to be adjusted.

Note:- Two independent set of parameters can be set. Motor 1 & Mmotor2.
Parameters 02-20 to 02-26. (Motor 2 can only function in V/f mode).

SLV & SV mode set parameters in parameter Group 17.

Three auto tune modes are available. Rotational/ Static & Resistance.
Selected by parameter 17-00

- Use rotational where possible. Motor rotates the process takes about 50 secs
- Use Static when rotation of load is not possible. It takes about 35 secs.
- Use line to Line resistance for long cable (above 50 meters in V/f mode)

Motor parameters in Group 2 are automatically set when performing an auto-tune (17-10=1). In most cases no adjustment is required after performing an auto-tune except when using the inverter in special applications (e.g. machine tool, positioning, etc...).

Enable auto tune function by parameter 17-10 =1.

Press **RUN button** to activate (after display showing “atredy”). Once successful the display will show end. If AtErr is shown check parameter 17-11 to identify the reason.

Group 17 Automatic Tuning Function Group				
Code	Parameter Name	Range	Default	Unit
17-00	Mode selection of automatic tuning	0: rotation autotune	0	-
		1: static autotune		
		2: stator resistance measurement		
17-01	Motor rated output power	0.00~600.00	-	KW
17-02	Motor rated current	0.1~999.9	-	A
17-03	Motor rated voltage	200V: 0.0~255.0	220	V
		400V:0.0~510.0	440	
17-04	Motor rated frequency	10.0~400.0 10.0~1200.0 (when 00-31 = 1)	60.0	Hz
17-05	Motor rated speed	0~24000	1750	rpm
17-06	Pole number of motor	2,4,6,8	4	Pole
17-07	Number of PG pulse	0~60000	1024	ppr
17-08	Motor no-load voltage	200V: 50~240	-	V
		400V100~480		
17-09	motor excitation current	0.01~600.00	-	A
17-10	Automatic tuning start	0: Disabled	0	-
		1: Enabled		
17-11	Auto tune Error History	0: No error 1: Motor data error 2: stator resistance tuning error 3:leakage induction tuning error 4: Rotor resistance tuning error 5: mutual induction tuning error 6: encoder error 7: DT Error 8: Motor's acceleration error 9: Warning	0	-

Note:-

No-load motor voltage (02-19) & 17-08

Parameter determines the rated flux during motor's rated rotation in **SLV or SV** control mode. Set the value of this parameter to the same value as parameter 17-08.

A value of 10~50V below the rated input voltage level (parameter 17-03) ensures that the motor is capable of providing adequate torque performance when operating at nominal speed (or higher speed).

Setting the value too small can result in a reduction in no-load current, weakened motor flux and an increase in motor current while the motor is loaded, causing a reduction in torque performance.

For high KW rating (55KW and above) set this closer to the supply voltage.

Motor excitation current 17-09 & (02-09)

This parameter is automatically set during auto-tune. No adjustment required.

For static tuning & Resistance tuning this parameter needs to be adjusted

Set to 1/3 of the motor rated current parameter (17-02).

Wiring Diagram

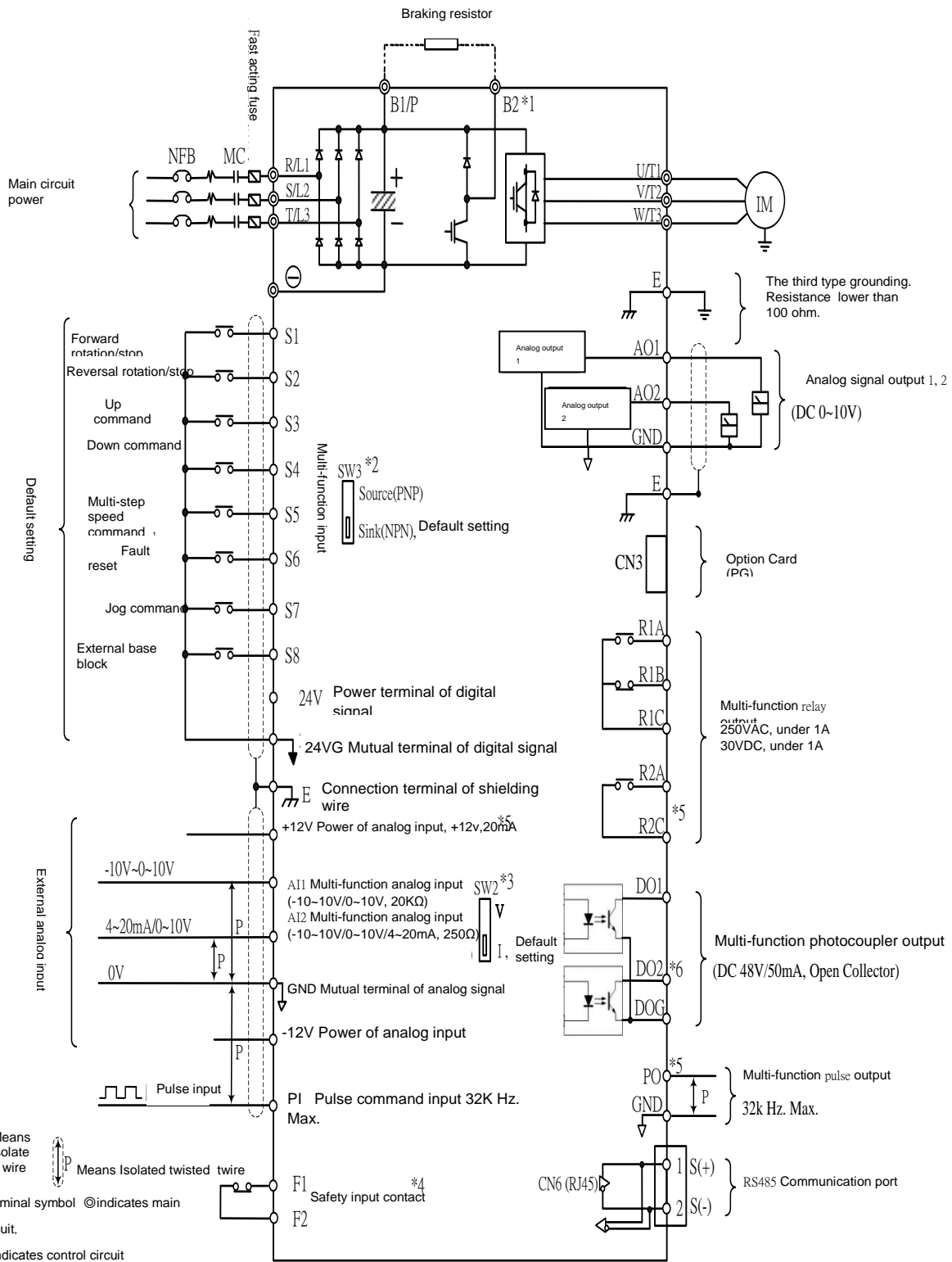

Remark:

- *1: Only the master circuit of 220V1~25HP and 440 V1~30HP (included) or models of lower capacity with built-in braking resistor provide terminal B2. The braking resistor can be connected directly between B1 and B2.
- *2: The multi-function digital input terminals S1~S8 can be set to Source (PNP) or Sink (NPN) mode through the SW3.
- *3: Multi-function analog input 2 (AI2) can be set to the voltage command input (0-10V/-10-10V) or the current command input (4~20mA) through the SW3.
- *4: Safety input connector F1 and F2 should be shorted so that the inverter outputs properly. When the safety input is used, please be sure to remove the short-pin between F1 and F2.
- *5: Only 220 V 3HP and 440 v 5HP (included) or models above, provide terminals -12V, R2A-R2C and PO- GND.
- *6: Only 220 V 2HP and 440 v 3HP (included) or models below, provide terminal DO2.